

Write your name here

Surname

Other names

Centre Number

Candidate Number

**Pearson Edexcel International
Primary Curriculum**

Science

Year 6 Achievement Test

Wednesday 11 June 2014 – Morning
Time: 1 hour

Paper Reference

JSC01/01

You do not need any other materials.

Total Marks

Instructions

- Use **black** ink or ball-point pen.
- **Fill in the boxes** at the top of this page with your name, centre number and candidate number.
- Answer **all** questions.
- Answer the questions in the spaces provided – *there may be more space than you need.*

Information

- The total mark for this paper is 60.
- The marks for **each** question are shown in brackets – *use this as a guide as to how much time to spend on each question.*
- Candidates may use a calculator.

Advice

- Read each question carefully before you start to answer it.
- Try to answer every question.
- Check your answers if you have time at the end.

Turn over ►

P44450A

©2014 Pearson Education Ltd.

6/6/6/5/3/



PEARSON

SECTION A

Answer ALL questions.

For questions 1 – 10 put a cross in one box to indicate your answer.
If you change your mind, put a line through the box and then put a cross in another box .
Each question is worth one mark.

1

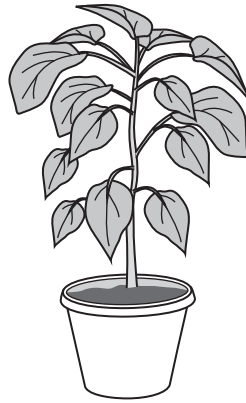

The main function of a plant leaf is to

- A attract insects.
- B collect water and nutrients.
- C hold the plant in place.
- D make food for the plant.

(Total for Question 1 = 1 mark)

2 What do we use to look at micro-organisms?

- A a micrometer
- B a microscope
- C a telescope
- D binoculars

(Total for Question 2 = 1 mark)







3 Which substance will dissolve in water?

- A flour
- B sand
- C sawdust
- D sugar

(Total for Question 3 = 1 mark)

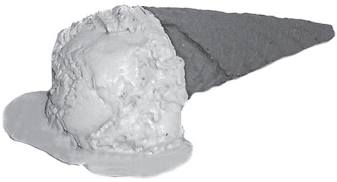
4 Which of these is a **reversible** change?

| | |
|--|---|
| <input type="checkbox"/> A baking a cake |  |
| <input type="checkbox"/> B frying an egg |  |
| <input type="checkbox"/> C melting ice cream |  |
| <input type="checkbox"/> D toasting bread |  |

(Total for Question 4 = 1 mark)

5 Weight is a force that is caused by

- A friction.
- B gravity.
- C space.
- D upthrust.

(Total for Question 5 = 1 mark)



6 When an object is **opaque**,

- A it will not form a shadow.
- B light cannot pass through it.
- C it is a source of light.
- D light passes through it.

(Total for Question 6 = 1 mark)

7 Students investigate how to light up a bulb. They set up these circuits.

In which circuit will the bulb light?

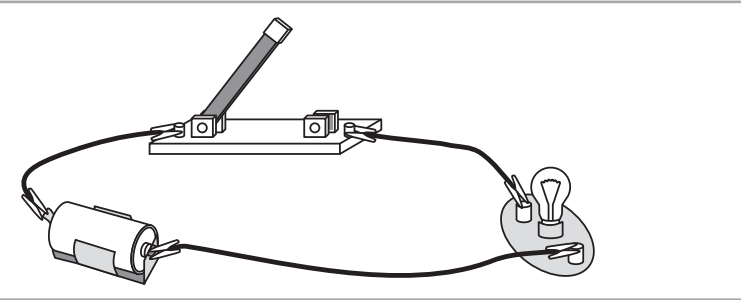
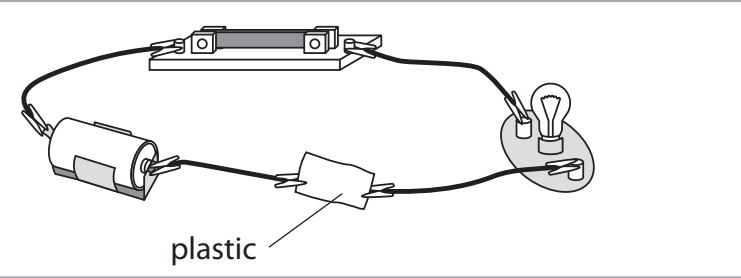
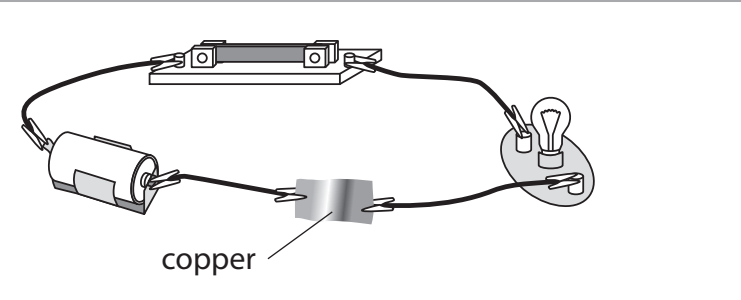
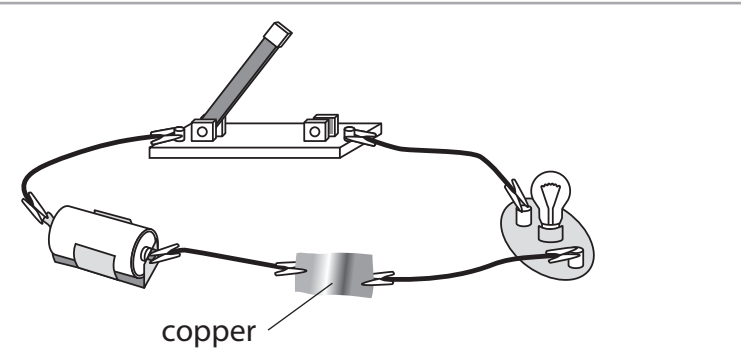
| | |
|----------------------------|--|
| <input type="checkbox"/> A |  |
| <input type="checkbox"/> B |  |
| <input type="checkbox"/> C |  |
| <input type="checkbox"/> D |  |

(Total for Question 7 = 1 mark)



8 An animal that is eaten by another animal is

- A a carnivore.
- B a consumer.
- C a predator.
- D prey.

(Total for Question 8 = 1 mark)

9 A solid dissolves when it is stirred in water.

It could be dissolved more quickly by

- A using hotter water.
- B using colder water.
- C stirring more slowly.
- D using larger pieces of solid.

(Total for Question 9 = 1 mark)

10 Some of the forces acting on this boat are shown by the arrows X, Y and Z.

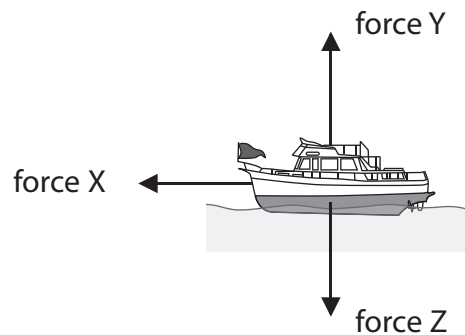

Which row names all 3 forces correctly?

| | Force X | Force Y | Force Z |
|----------------------------|----------------|----------------|----------------|
| <input type="checkbox"/> A | weight | upthrust | forward force |
| <input type="checkbox"/> B | forward force | weight | upthrust |
| <input type="checkbox"/> C | forward force | upthrust | weight |
| <input type="checkbox"/> D | upthrust | forward force | weight |

(Total for Question 10 = 1 mark)



11 Lauren and David start to separate a mixture of water, gravel and salt.

This is the equipment they use.

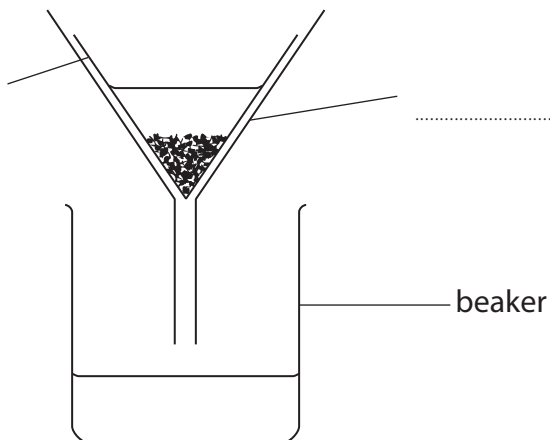

(a) The beaker has been labelled. Add the other two labels on the diagram above. (2)

(b) Explain where the salt will be after they have used this equipment. (2)

The salt will be

Explanation

.....

(Total for Question 11 = 4 marks)



12 Micro-organisms are living things.

They can cause disease and decay but they can also be useful to us.

(a) State **one** way that micro-organisms can be useful.

(1)

(b) List **three** things that all living organisms can do.

(3)

- 1
- 2
- 3

(Total for Question 12 = 4 marks)

13 Electricity needs to be used safely. It can cause an electrical shock.

Look at the picture of the kitchen.

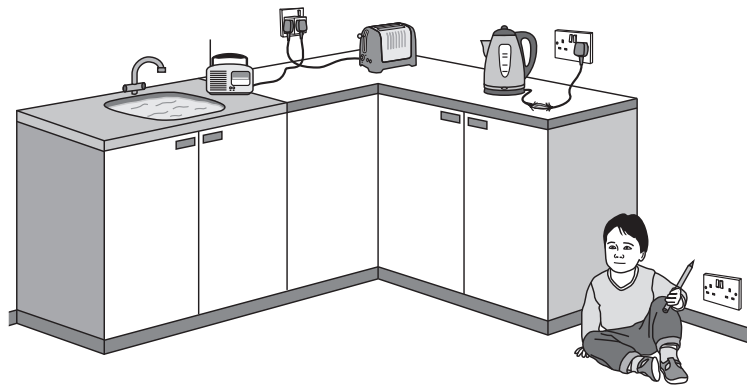

List **three** electrical hazards you can see in the picture.

- 1
- 2
- 3

(Total for Question 13 = 3 marks)

14 What instrument is used to measure electric current?

(1)

.....
(Total for Question 14 = 1 mark)







For questions 15 – 23 put a cross in one box to indicate your answer.
 If you change your mind, put a line through the box and then put a cross in another box .
 Each question is worth one mark.

15 Which of these is a source of light?

- A a battery
- B a candle
- C an eye
- D the Moon

(Total for Question 15 = 1 mark)

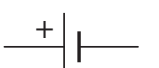
16 Which of these is the symbol for a buzzer?

| | |
|----------------------------|---|
| <input type="checkbox"/> A |  |
| <input type="checkbox"/> B |  |
| <input type="checkbox"/> C |  |
| <input type="checkbox"/> D |  |

(Total for Question 16 = 1 mark)

17 Which is the producer in this food chain?



A rice



B rat



C snake



D hawk

(Total for Question 17 = 1 mark)



18 What is the unit of force?

- A amp
- B centimetre
- C gram
- D newton

(Total for Question 18 = 1 mark)

19 Light reflects off shiny surfaces.

Which diagram shows the direction light travels when we see an object in a mirror?

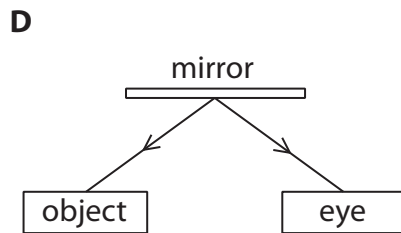
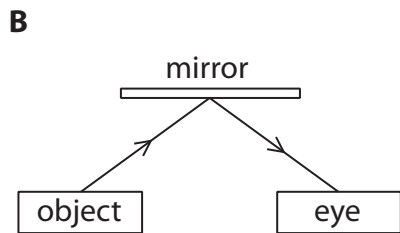
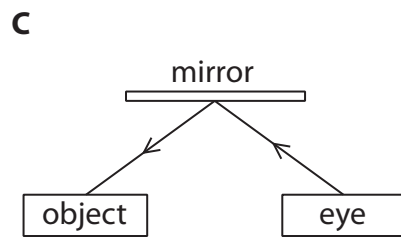
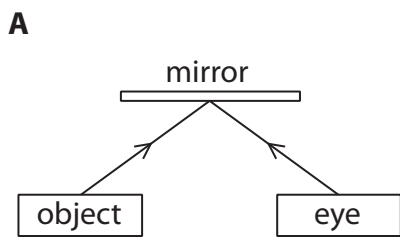

- A
- B
- C
- D

(Total for Question 19 = 1 mark)



20 All the bulbs in the circuits will light up.

Which circuit will have the brightest bulb?

A

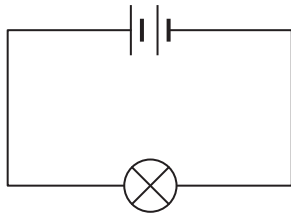

C

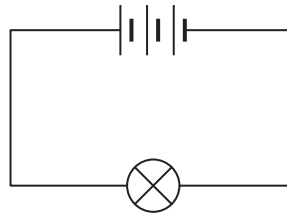

B

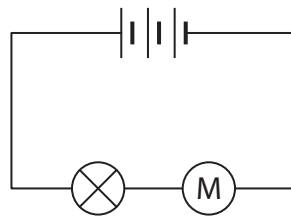

D

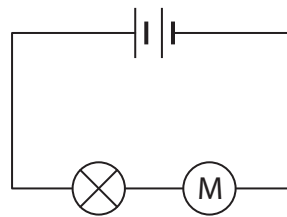

- A
- B
- C
- D

(Total for Question 20 = 1 mark)

21 An animal that only eats plants is a

- A carnivore.
- B herbivore.
- C predator.
- D producer.

(Total for Question 21 = 1 mark)

22 Shaving foam is an example of

- A a gas in a solid.
- B a liquid in a liquid.
- C a liquid in a solid.
- D a gas in a liquid.

(Total for Question 22 = 1 mark)



23 A toy car moves forwards along a flat, level floor.

Which of these force diagrams shows the car slowing down?



(Total for Question 23 = 1 mark)

24 Jenny is trying to identify this plant.



Write down **two** features of the plant that she could use to identify it.

1

2

(Total for Question 24 = 2 marks)



25 Rays are a type of fish that have adapted to their surroundings.

Draw a line to link each ray with the type of seabed it lives on.

Ray

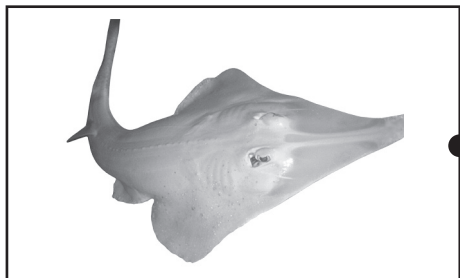
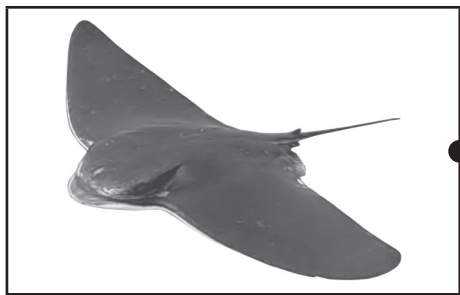
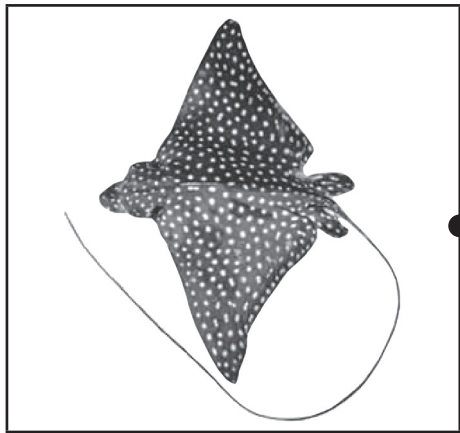

Type of seabed

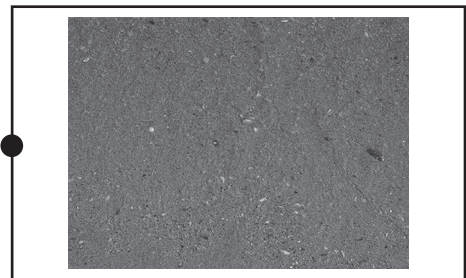
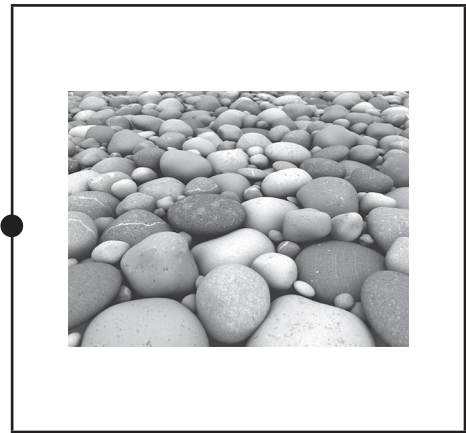

(Total for Question 25 = 2 marks)



BLANK PAGE



26 Becky investigates what happens when she adds different solids to water.

She:

- adds solid A in small, weighed amounts, to 100 cm³ of water.
- stirs the water each time.
- keeps adding the solid until no more dissolves.
- records the mass of solid added.
- repeats this for solid B, solid C and solid D.

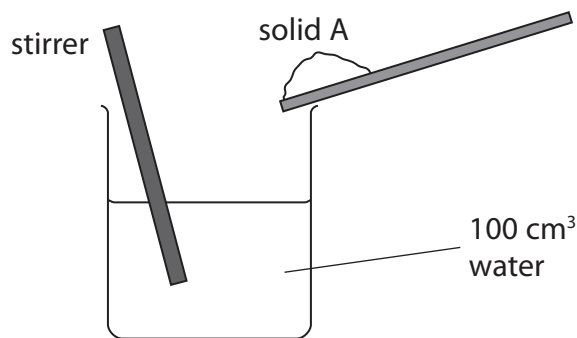

She records her results in a bar chart.

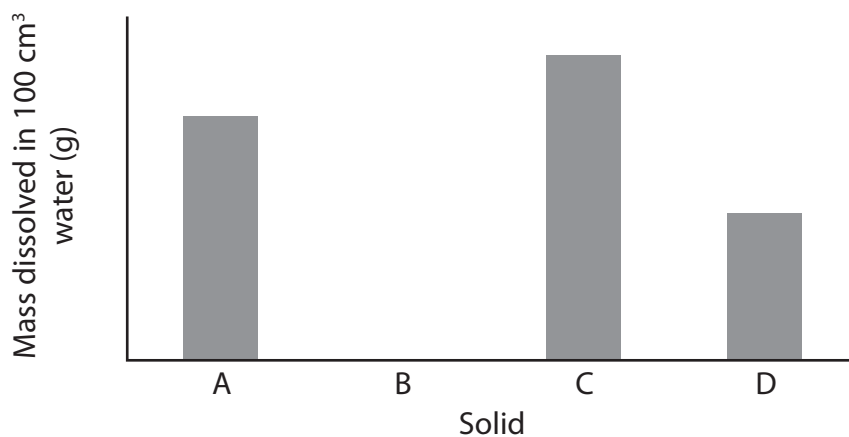

(a) What is made when a solid dissolves in a liquid?

(1)

(b) What does the bar chart suggest about solid B?

(1)

(c) From the bar chart, give a conclusion about solid C compared to solid D.

(1)



(d) Becky wants to get solid A back. What does she need to do?

(1)

.....

.....

(Total for Question 26 = 4 marks)



For questions 27 – 32 put a cross in one box to indicate your answer.
If you change your mind, put a line through the box and then put a cross in another box .
Each question is worth one mark.

27 What do fertilisers provide for plants?

- A nutrients
- B soil
- C water
- D worms

(Total for Question 27 = 1 mark)

28 Plants of the same type differ in appearance. This is called

- A adaptation.
- B germination.
- C organism.
- D variation.

(Total for Question 28 = 1 mark)

29 A mixture of sand and iron filings can be separated by

- A adding water.
- B a magnet.
- C filtration.
- D sieving.

(Total for Question 29 = 1 mark)

30 An example of an emulsion is

- A black coffee.
- B olive oil.
- C orange juice.
- D salad dressing.

(Total for Question 30 = 1 mark)



31

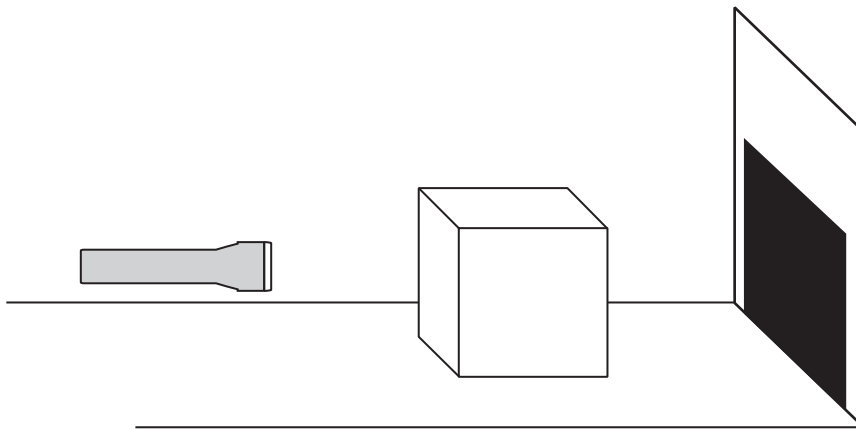

The torch is moved towards the box. What happens to the shadow?

- A It gets smaller.
- B It gets larger.
- C It stays the same size.
- D It disappears.

(Total for Question 31 = 1 mark)

32 Which of these is an irreversible change?

- A burning
- B evaporating
- C freezing
- D stirring

(Total for Question 32 = 1 mark)

TOTAL FOR SECTION A = 45 MARKS



P 4 4 4 5 0 A 0 1 7 2 4

SECTION B

Answer ALL questions.

33 This instrument is used for measuring temperature.

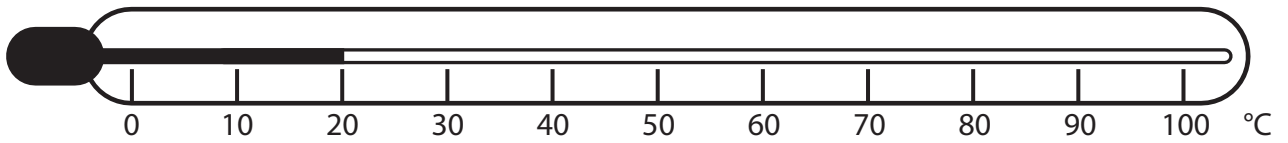

(a) Name the instrument (1)

(b) What temperature is it showing?°C (1)

(c) What would happen to the temperature reading if the instrument was put inside a refrigerator?

..... (1)

(Total for Question 33 = 3 marks)



34 The diagram shows four pieces of equipment.

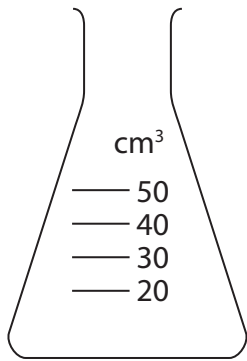

1

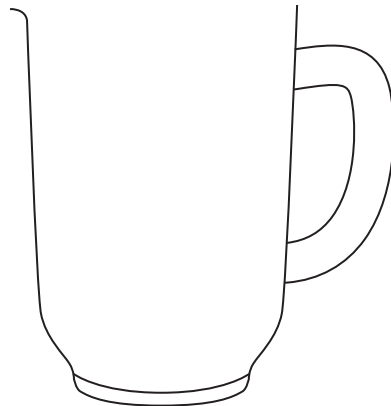

2

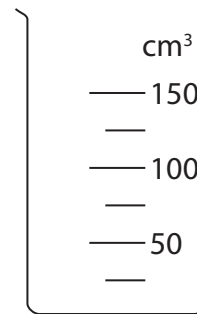

3

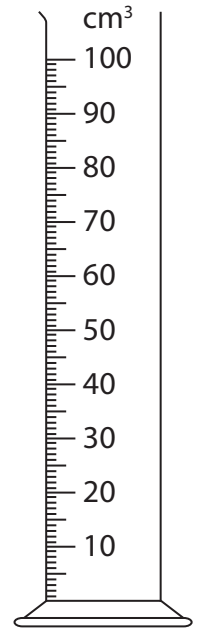

4

(a) Which of these would be best for measuring 65 cm³ of water accurately?

Number

(1)

(b) Explain your choice.

.....
.....
(1)

(Total for Question 34 = 2 marks)



BLANK PAGE



35 Advertisements about paper towels are often shown on television and in magazines.



Abdul is investigating three different paper towels to see which one is best at soaking up water.

Complete parts (a), (b) and (c) of Abdul's planning sheet.

PLANNING SHEET

There are 3 different paper towels A, B and C. Investigate how many pieces of each paper towel are needed to soak up the same amount of water.

(a) I will make my investigation a fair test by keeping these two variables the same:

1

2

(2)

(b) I will need:

- 3 different paper towels
- scissors
- a ruler
- water
- a saucer to put the water on
- a to measure the volume of water

(1)

(c) I will repeat the experiment with each paper towel three times so that

.....

.....

(1)



(d) The table below shows the number of pieces of each paper towel needed to soak up the same amount of water.

| Paper towel | Number of pieces of paper towel needed | | | |
|-------------|--|----------|----------|---------|
| | 1st test | 2nd test | 3rd test | Average |
| A | 5 | 4 | 6 | 5 |
| B | 3 | 3 | 3 | 3 |
| C | 7 | 7 | 14 | 7 |

(i) Abdul ignored one of the results because he thought it was not accurate. Circle this result on the table.

(1)

(ii) Explain your choice.

(1)



(e) Complete the bar chart to show the average number of pieces needed for paper towels A and B.

(i) Label both axes. (1)

(ii) Draw both bars. (1)

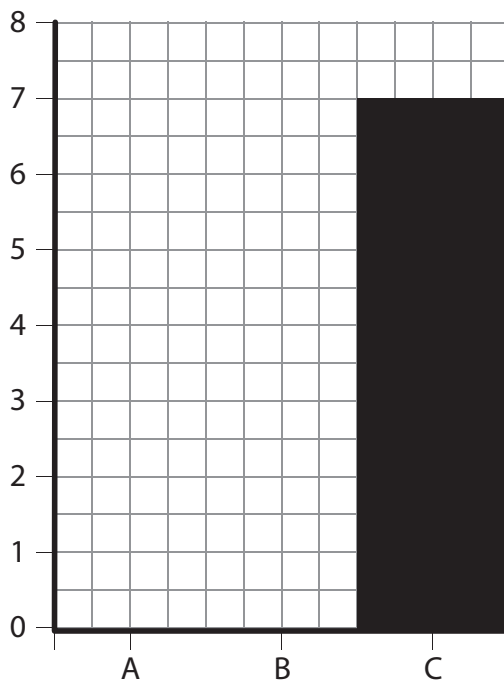

(f) The paper towel that soaks up most water is (1)

Explain your answer.

.....

.....

(1)

(Total for Question 35 = 10 marks)

TOTAL FOR SECTION B = 15 MARKS
TOTAL FOR PAPER = 60 MARKS



BLANK PAGE

