

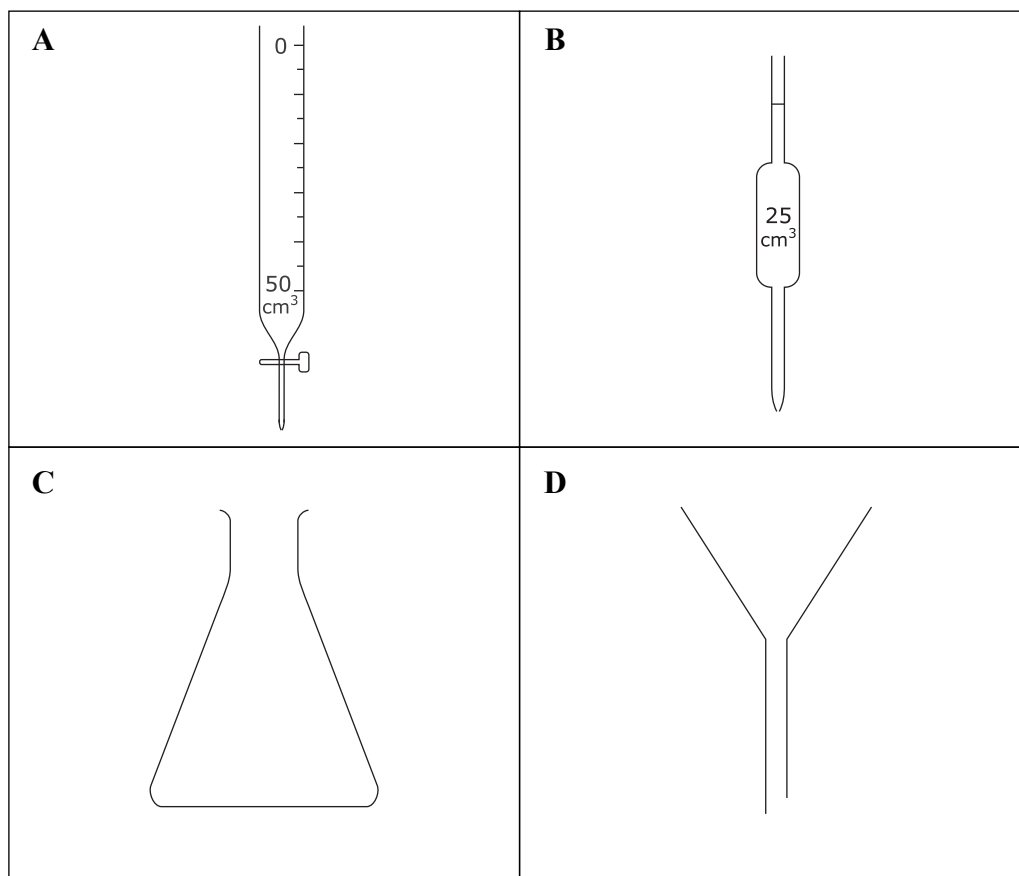

**BLANK PAGE**



1. (a) These pieces of apparatus are used in the laboratory.



Give the name of each piece of apparatus.

**A** .....

**B** .....

**C** .....

**D** .....

**(4)**

(b) Choose **A**, **B**, **C** or **D** to identify which piece of apparatus is the most suitable for

(i) removing insoluble substances from a solution .....

**(1)**

(ii) measuring the volume of exactly 30.0 cm<sup>3</sup> of a liquid .....

**(1)**

**(Total 6 marks)**

**Q1**



2. Paper chromatography can be used to separate a mixture of food dyes (**M**), and to identify the dyes by comparison. The diagram shows the apparatus used.

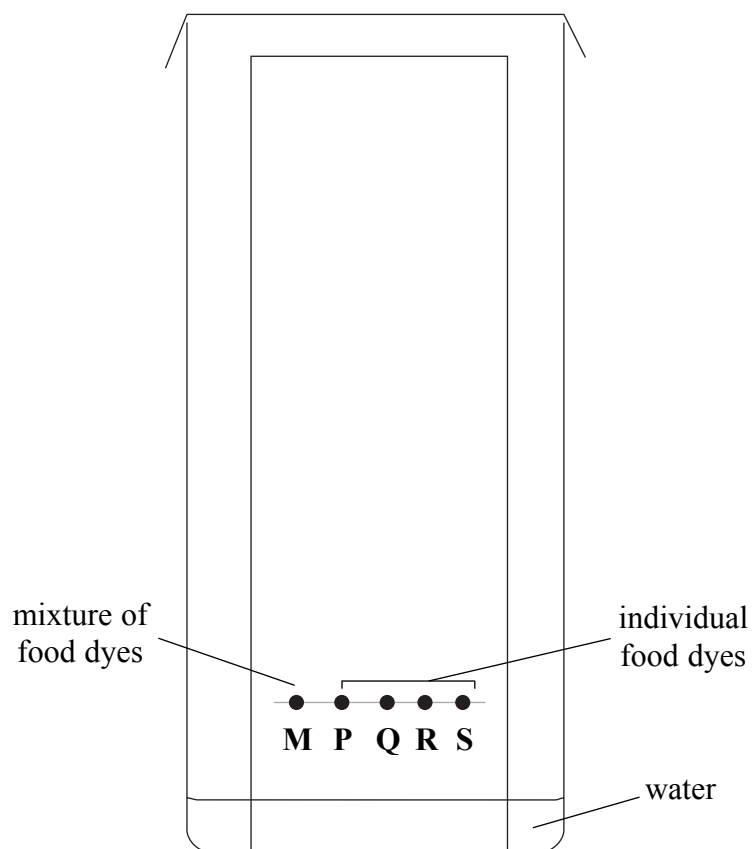

(a) The food dyes are placed on the paper about 2 cm up from the bottom edge. Why is it important **not** to place them at the bottom of the paper?

.....  
.....  
(1)

(b) State **two** observations you would make during the experiment.

1 .....  
.....  
2 .....  
.....  
(2)



(c) At the end of the experiment the paper is removed and dried. The diagram shows the paper.

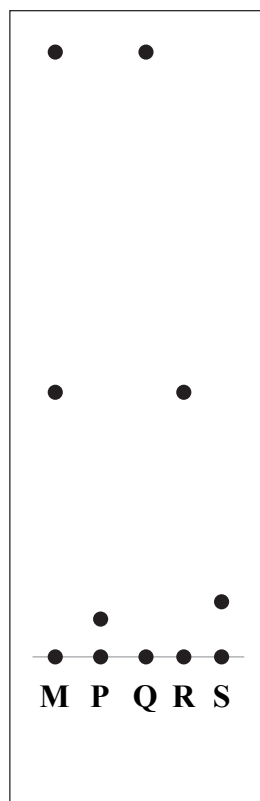

(i) Measure the distance moved by food dye **R** during the experiment.

.....  
(1)

(ii) Which of the food dyes **P**, **Q**, **R** and **S** are present in **M**?

.....  
(1)

(iii) Food dyes **P** and **S** moved very little. Suggest **one** change you could make to this experiment to help them move further.

.....  
(1)

(Total 6 marks)

Q2



3. Many organic liquids are volatile (easily evaporated by warming). A teacher asks a class to suggest an experiment to compare the volatility of different organic liquids. One student suggests this method.

- Put some organic liquid into an evaporating dish
- Place it on top of a beaker of hot water
- Time how long it takes for all the liquid to evaporate
- Repeat the experiment for other organic liquids

The diagram shows the apparatus.

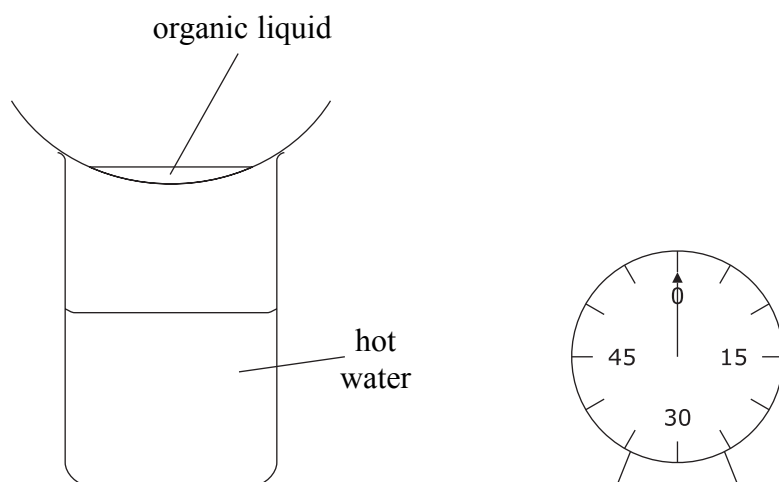

(a) State **one** factor that should be kept the same when repeating the experiment with other organic liquids.

.....  
 .....  
**(1)**

(b) Another student suggests heating the evaporating dish with a Bunsen burner. Why is this method not safe?

.....  
**(1)**



(c) A student records the temperature of the water in the beaker at the start of the experiment and the time taken for the organic liquid to evaporate.

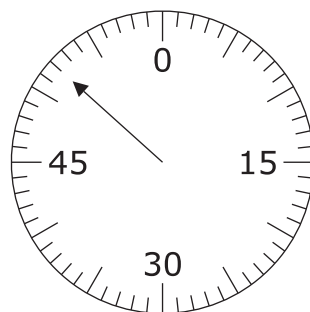
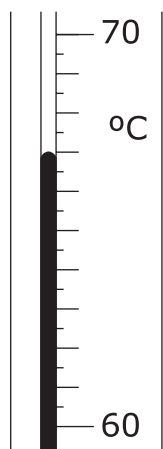

What are the values shown?

Temperature ..... °C

Time ..... seconds

(2)

**QUESTION 3 CONTINUES ON PAGE 8**



- (d) The table shows the results of four experiments (Expt 1 – Expt 4) by other students using the same method under the same conditions.

Organic liquid	Time for liquid to evaporate (seconds)				
	Expt 1	Expt 2	Expt 3	Expt 4	Average
V	80	75	90	75	80
W	55	60	60	65	60
X	30	40	–	–	35
Y	45	50	55	50	
Z	100	90	70	80	85

- (i) Which organic liquid has the greatest variation in times?

.....  
(1)

- (ii) For which organic liquid should more results be obtained?

.....  
(1)

- (iii) Calculate the average time for liquid Y to evaporate.

.....  
.....  
(1)

- (iv) Which of these organic liquids is the least volatile?

.....  
(1)

- (v) Which of these organic liquids has the weakest intermolecular forces?

.....  
(1)





- (e) The teacher asked the students to suggest other ways to compare the volatility of organic liquids.  
One student suggested using this apparatus, which is usually used to separate a mixture of liquids.

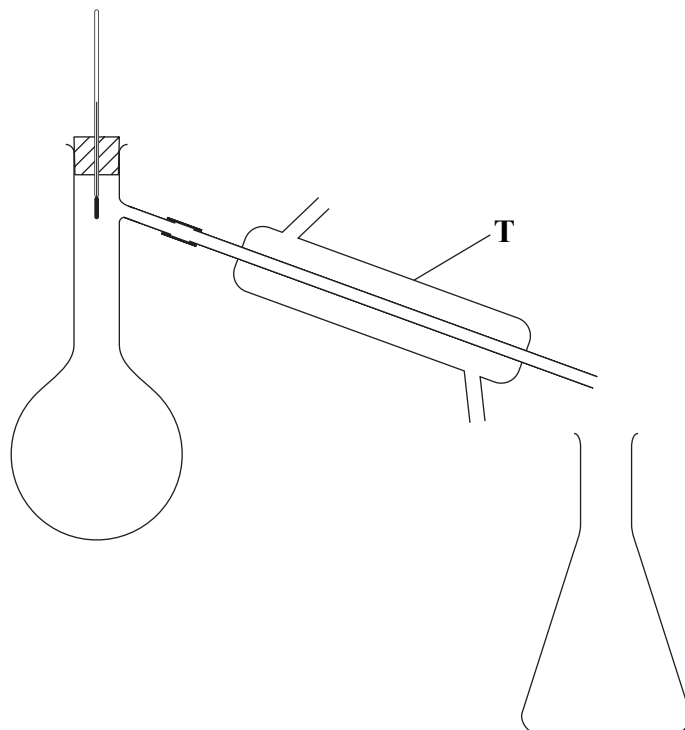

- (i) What name is used for this method of separation?

..... (1)

- (ii) Label the apparatus to show where to put the liquid at the start of the experiment. (1)

- (iii) Name the piece of apparatus T.

..... (1)

- (iv) What property of the organic liquid would be measured during the experiment?

..... (1)

(Total 13 marks)

Q3

--	--



4. A class does some experiments to measure the approximate percentage of oxygen in air. Air is passed several times over some heated copper powder.

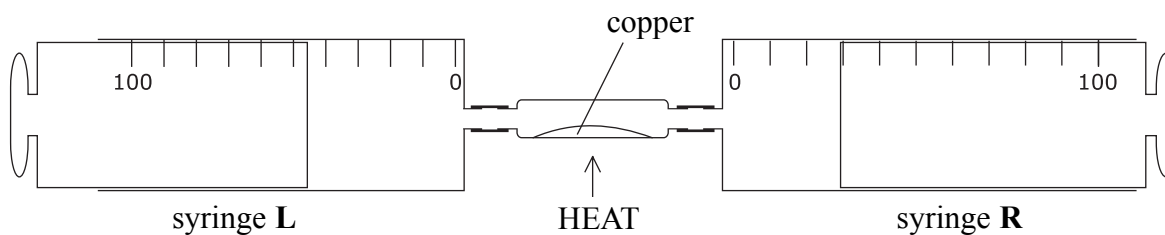

The copper is strongly heated using a Bunsen burner. Syringe **L** is slowly pushed in to pass air over the heated copper. The same is then done with syringe **R**. This is repeated until the total amount of gas in the two syringes remains constant.

The equation for the reaction that occurs is

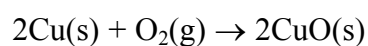

- (a) The temperature of the room is 20°C before heating the copper. Why is it important to let the apparatus cool to 20°C before recording the volumes of gas at the end of the experiment?

..... (1)



(b) The table shows the results obtained by one group of students.

Experiment	Volumes of air at start (cm <sup>3</sup> )			Volumes of gas at end (cm <sup>3</sup> )		
	Syringe L	Connecting tubing	Syringe R	Syringe L	Connecting tubing	Syringe R
1	100	20	0	0	20	75
2	0	20	90	69	20	0
3	0	20	80	0	20	62
4	70	20	0	52	20	0
5	0	20			20	0

(i) These are the readings on the syringes in experiment 5.

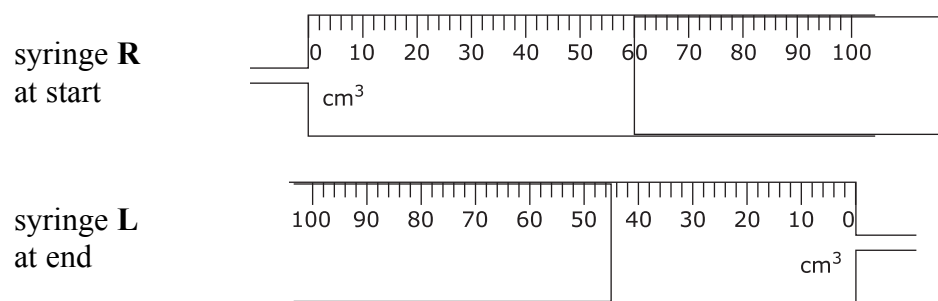

Enter the readings in the table above.

(2)

(ii) Complete the table below.

Experiment	Total volume of air at start (cm <sup>3</sup> )	Total volume of gas at end (cm <sup>3</sup> )	Volume of oxygen removed (cm <sup>3</sup> )
1	120	95	25
2	110	89	21
3	100	82	18
4			

(2)



(c) Another group of students obtained these results.

Experiment	Total volume of air at start (cm <sup>3</sup> )	Total volume of gas at end (cm <sup>3</sup> )	Volume of oxygen removed (cm <sup>3</sup> )
6	120	95	25
7	90	72	18
8	100	81	19
9	110	88	22
10	80	67	13

Use the results for experiments 6–10 to plot a graph of volume of oxygen removed against total volume of air at start. Draw a line of best fit.

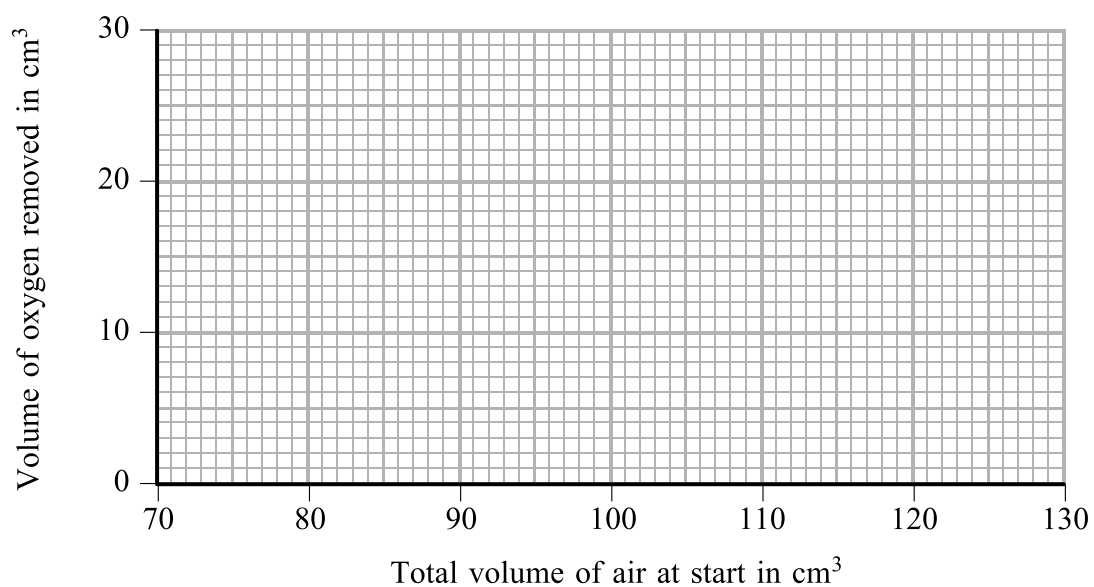

(3)

(d) Circle on the graph **one** result that is anomalous.

(1)



(e) One student said she could use a quicker method. The diagram shows the apparatus.

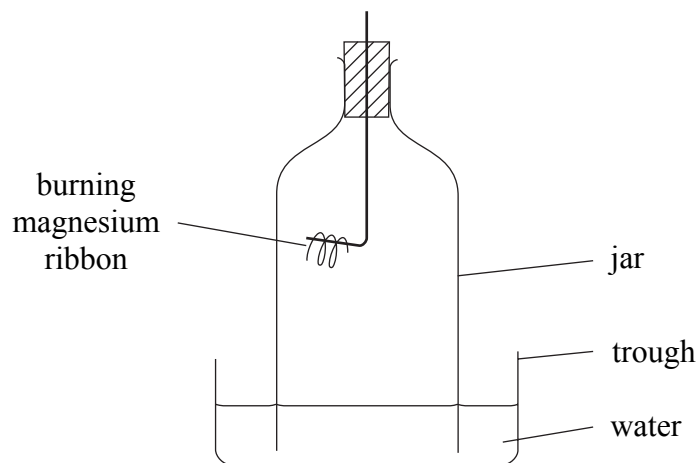

(i) How would the water level in the jar be different at the end of the experiment?

.....  
(1)

(ii) How does the magnesium cause this change in water level?

.....  
.....  
(1)

(iii) Suggest why this method would give less accurate results than the syringe method.

.....  
.....  
(1)

(Total 12 marks)

Q4



5. Hydrogen peroxide solution decomposes into water and oxygen gas.

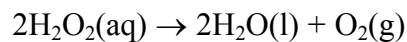

The reaction is speeded up by using a catalyst.

The rate of this reaction is followed by measuring how long it takes to collect 100 cm<sup>3</sup> of oxygen gas.

This apparatus is used.

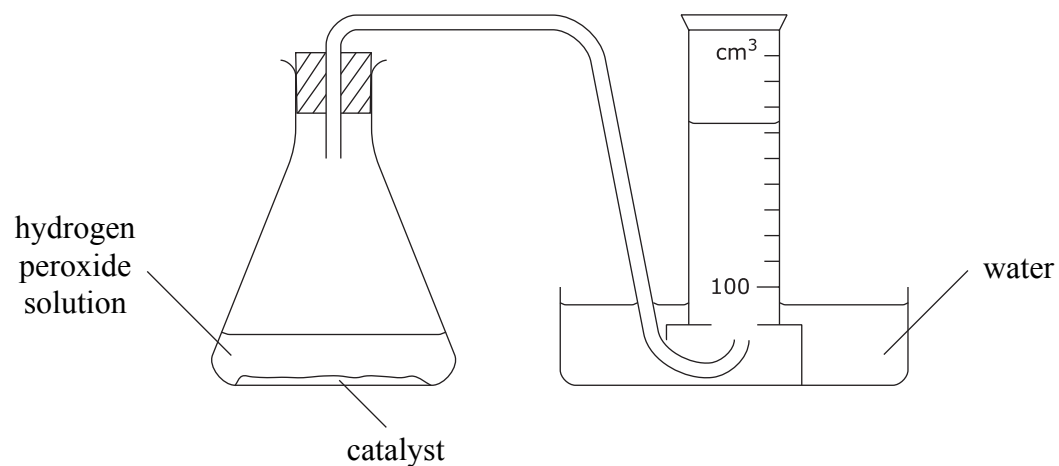

Some students investigate how changing the concentration of hydrogen peroxide solution affects the rate of the reaction.

They all agree to

- use manganese(IV) oxide as the catalyst
- use a total of 50 cm<sup>3</sup> of diluted hydrogen peroxide solution
- collect 100 cm<sup>3</sup> of oxygen gas.

The table shows their results.

Student	Volume of H <sub>2</sub> O <sub>2</sub> (aq) (cm <sup>3</sup> )	Volume of water (cm <sup>3</sup> )	Time to collect 100 cm <sup>3</sup> of oxygen (seconds)
A	40	10	20
B	20	30	71
C	25	25	40
D	30	30	50
E	35	15	25



- (a) State **one** factor that should be kept the same to make the investigation a fair test at room temperature.

.....  
**(1)**

- (b) Which student did not use the agreed volume of diluted hydrogen peroxide solution?

.....  
**(1)**

- (c) Complete the table to show the percentage concentration of diluted hydrogen peroxide solution and the rate of production of oxygen gas.

The rate of production of oxygen can be found by using the equation

$$\text{Rate of production of oxygen} = \frac{1000}{\text{Time to collect } 100\text{ cm}^3 \text{ of oxygen}}$$

Student	Concentration of hydrogen peroxide solution (%)	Rate of production of oxygen (/s)
A	80	50
B		
C		
D		
E		

**(4)**

**QUESTION 5 CONTINUES ON PAGE 16**



(d) Another group of students followed the same instructions and obtained these data.

Student	Concentration of hydrogen peroxide solution (%)	Rate of production of oxygen (/s)
F	80	38
G	60	28
H	50	22
I	40	20
J	20	9

(i) Draw a graph of the data obtained by students F to J.

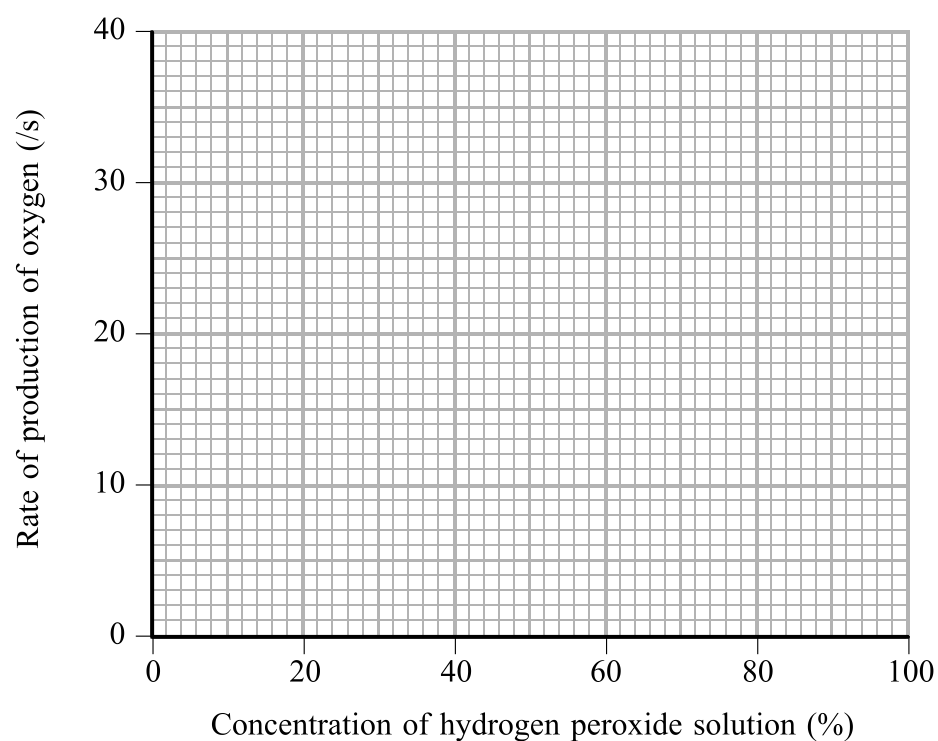

**(3)**

(ii) What is the relationship between the rate of reaction and the concentration of hydrogen peroxide solution?

.....  
 .....

**(1)**





Leave  
blank

- (e) Another group of students uses the same apparatus to investigate whether other solids work as catalysts in this reaction.  
Outline the method they should use.

.....

.....

.....

.....

.....

.....

.....

.....

.....

(3)

Q5

(Total 13 marks)

**TOTAL FOR PAPER: 50 MARKS**

**END**



**BLANK PAGE**



**BLANK PAGE**



**BLANK PAGE**

