

Centre No.						Paper Reference					Surname	Initial(s)	
Candidate No.						4	4	2	0	/	1	F	Signature

Paper Reference(s)

4420/1F

London Examinations IGCSE

Physics

Paper 1F

Foundation Tier

Wednesday 16 June 2010 – Morning

Time: 1 hour 30 minutes

Materials required for examination

Nil

Items included with question papers

Nil

Examiner's use only

--	--	--

Team Leader's use only

--	--	--

Question Number	Leave Blank
1	
2	
3	
4	
5	
6	
7	
8	
9	
10	
11	
12	
13	
14	
15	
16	
Total	

Instructions to Candidates

In the boxes above, write your centre number, candidate number, your surname, initial(s) and signature.

The paper reference is shown at the top of this page. Check that you have the correct question paper.

Answer **ALL** the questions. Write your answers in the spaces provided in this question paper.

Some questions must be answered with a cross in a box (☒). If you change your mind about an answer, put a line through the box (☒) and then mark your new answer with a cross (☒).

Show all the steps in any calculations and state the units.

Calculators may be used.

Information for Candidates

The total mark for this paper is 100. The marks for individual questions and the parts of questions are shown in round brackets: e.g. (2). There are 16 questions in this question paper.

Any blank pages are indicated.

Useful formulae are given on page 2.

Advice to Candidates

Write your answers neatly and in good English.

This publication may be reproduced only in accordance with Edexcel Limited copyright policy. ©2010 Edexcel Limited.

Printer's Log. No.
N36906A

W850/U4420/57570 6/7/6/



Turn over

edexcel 
advancing learning, changing lives

FORMULAE

You may find the following formulae useful.

$$\text{power} = \frac{\text{work done}}{\text{time taken}}$$

$$P = \frac{W}{t}$$

$$\text{power} = \frac{\text{energy transferred}}{\text{time taken}}$$

$$P = \frac{W}{t}$$

$$\text{frequency} = \frac{1}{\text{time period}}$$

$$f = \frac{1}{T}$$

Where necessary, assume the acceleration of free fall, $g = 10 \text{ m/s}^2$.



1. (a) Two students, **A** and **B**, walk across a classroom. The other students take readings of distance and time.
The readings are used to plot the following graph.

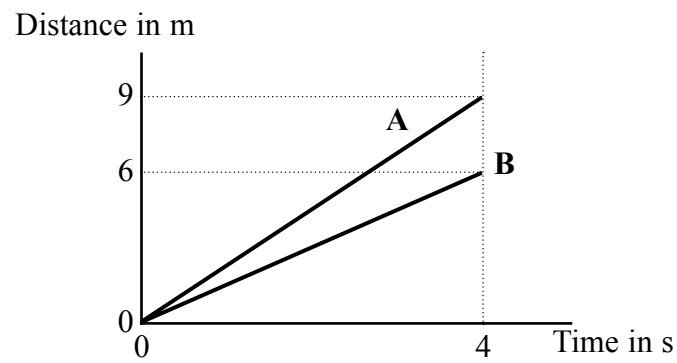

- (i) Complete the sentence.

The line for student **A** is steeper than the line for student **B**.

This shows that student **A** is walking than student **B**.
(1)

- (ii) Use words from the box to complete the sentence.

acceleration horizontal speed straight vertical

The graph shows that each student walks at a steady
because the lines are both
(2)

- (b) After 4 seconds, what is the distance between the students **A** and **B**?

Distance = m
(2)

- (c) (i) State the equation which relates average speed, distance and time.

.....
.....
(1)

- (ii) Calculate the average speed of student **B**, giving the unit.

Speed of student **B** =
(2)

(Total 8 marks)

Q1



2. An electric body warmer is worn by a motorcyclist.
The diagram shows a design for an electric body warmer.

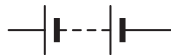
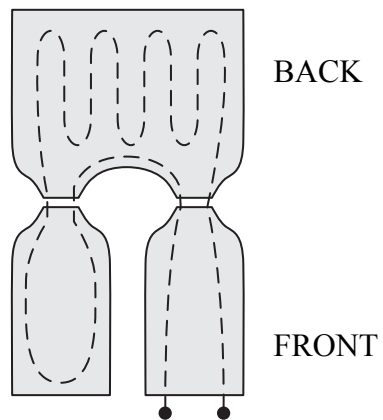

The dashed line shows a wire. When a 12 V battery is connected to the body warmer there is a current in the wire.

(a) On the diagram draw wires connecting the body warmer to the battery. (1)

(b) Place a cross (☒) in one box to show which of the following terms best describes the circuit.

- A Parallel
 - B Racing
 - C Series
 - D Short
- (1)

(c) Explain why, in this design, the front of the body warmer would produce less heat than the back.

.....

(1)

(d) Suggest one other design fault.

.....

(1)



(e) Place a cross (☒) in one box to show which of the following properties of the wire needs to be known if the current in the body warmer is to be calculated.

- A colour
- B density
- C mass
- D resistance

(1)

(f) Name two appliances which use electrical heating in the home.

1

2

(2)

(Total 7 marks)

Leave
blank

Q2

5

Turn over



N 3 6 9 0 6 A 0 5 2 4

Leave blank

3. (a) The box contains the names of different parts of the electromagnetic spectrum.

gamma rays	infra-red	microwaves	radio waves	ultraviolet	visible	X-rays
-------------------	------------------	-------------------	--------------------	--------------------	----------------	---------------

(i) Fill in the gaps in the chart below to put these parts into their correct order.

radio waves			visible			gamma rays
--------------------	--	--	----------------	--	--	-------------------

(3)

(ii) Use words from the box below to complete the sentences.

You may use each word once, more than once or not at all.

amplitude	frequency	speed	wavelength
------------------	------------------	--------------	-------------------

Listing the parts from radio waves to gamma rays puts them in order

of increasing and

decreasing

All the parts have the same in free space.

(3)

(b) State

(i) a use of infra-red;

.....
(1)

(ii) a harmful effect of over-exposure to infra-red.

.....
(1)

Q3

(Total 8 marks)



4. (a) Complete the sentence.

When sound waves are reflected from a surface, the angle of

..... equals the angle of (1)

(b) The diagram shows a pair of reflectors. All sound waves starting from the point **A** reflect off the reflectors to the point **B**. The path of one wave has been drawn.

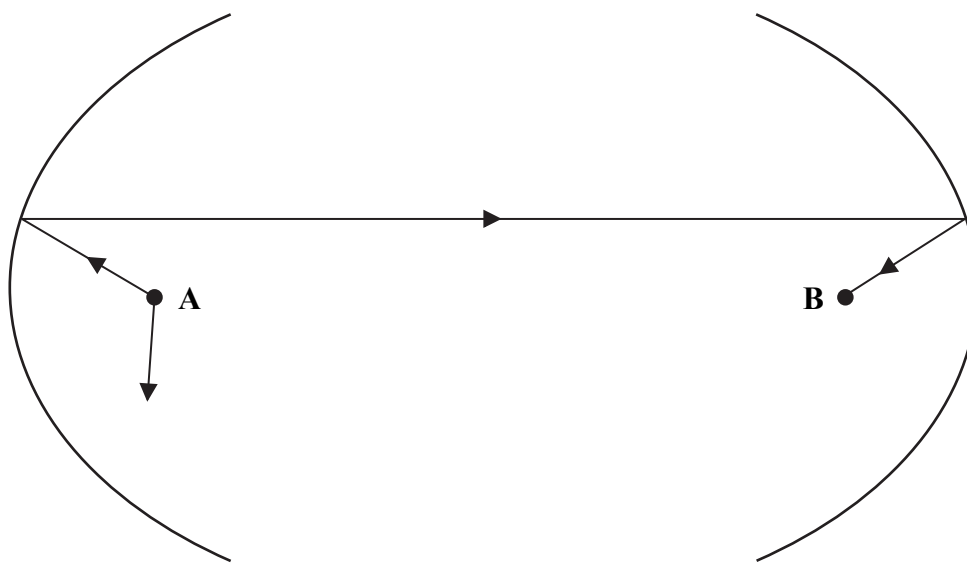

(i) Complete the path of the other wave. (2)

(ii) Why is the sound loud at point **B**?
.....
..... (1)

(c) What type of wave is a sound wave in air?
..... (1)

(d) A source of sound is removed from **A** and a heater is placed at point **B**. What would be noticed at point **A**?
..... (1)

(Total 6 marks)

Q4



5. (a) Use terms from the box to complete the equation for efficiency.

total energy input	total energy output
useful energy input	useful energy output

Efficiency = _____

(1)

(b) The flow diagram shows the energy transfer for a lamp.

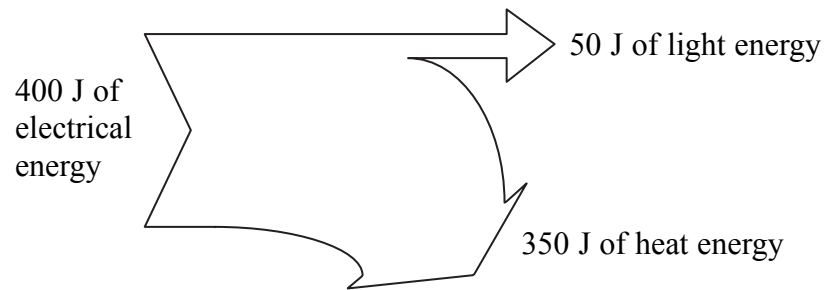

(i) Use words from the box to complete the sentence.

conserved	convected	efficient	inefficient
------------------	------------------	------------------	--------------------

The diagram shows that energy is and that the lamp is as a source of light.

(2)

(ii) The lamp gives out 50 joules of light energy in 10 seconds. How much light energy does it give out in one second?

.....
.....

Light energy per second = J/s
(2)

(iii) What other unit is the same as a joule per second?

.....

(1)

Q5

(Total 6 marks)



Leave blank

6. (a) Name two sources of background radiation.

1

2

(2)

(b) A radioactive source has an activity of 40 Bq. It has a half-life of 3 hours.

(i) What is the name of the unit which the letters Bq represent?

.....

(1)

(ii) What is meant by half-life?

.....

.....

(2)

(iii) How long does it take for the measured activity to change from 40 Bq to 10 Bq?

.....

.....

Time taken = hours

(2)

(iv) What assumption have you made about background radiation in your answer to (iii)?

.....

(1)

(c) State two uses of radioactivity.

1

.....

2

.....

(2)

Q6

(Total 10 marks)



Leave blank

7. A student stands on a beam which is supported on two electronic balances **A** and **B**.

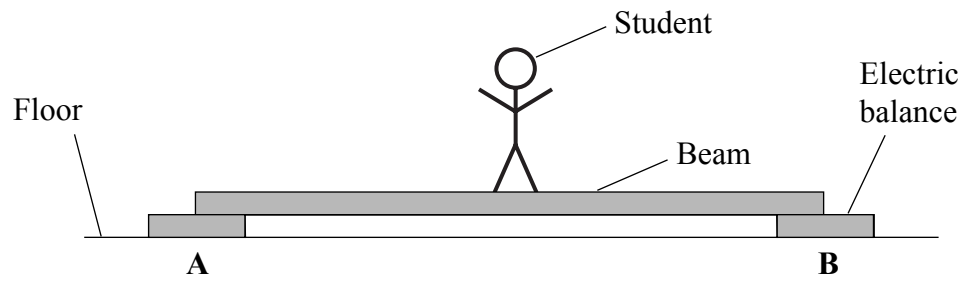

The reading on both balances is 26 kg.

(a) What is the position of the student on the beam?

..... (1)

(b) The student moves towards **A**.
Use words from the box to complete the sentence.

decreases increases stays the same

The reading at **A**
and the reading at **B** (1)

(c) Another student says that 'the weight of the student is 26 kg'.
Give three reasons why this statement may be incorrect.

1
.....
2
.....
3
..... (3)

(Total 5 marks)

Q7



Leave blank

8. (a) The diagram shows a transformer.
Use the terms from the box to label the diagram.

core input coil output coil power supply

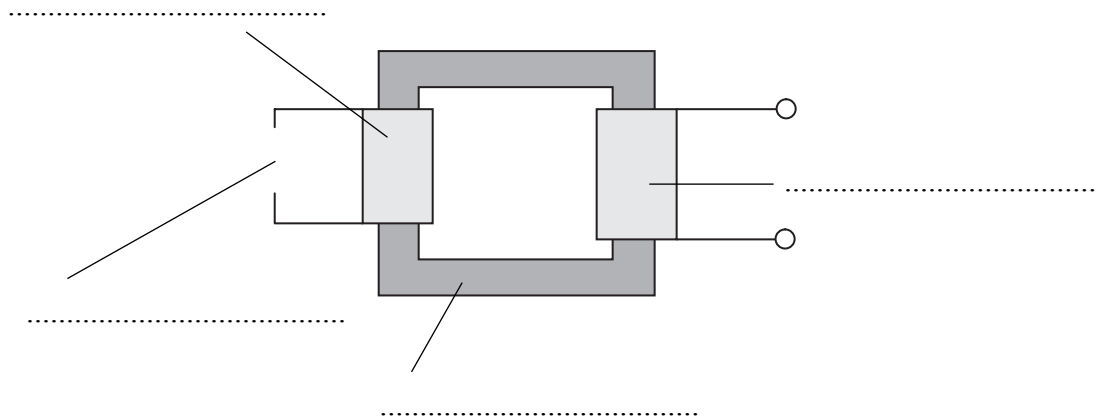

(3)

- (b) This transformer is a step-up transformer.

- (i) Describe the difference between the input coil and the output coil.

.....
.....

(1)

- (ii) State where a step-up transformer would be used in a large-scale electricity transmission system.

.....
.....

(1)

Q8

(Total 5 marks)



9. The circuit diagram shows how a student connects several components. These include four identical 1.5 volt cells.

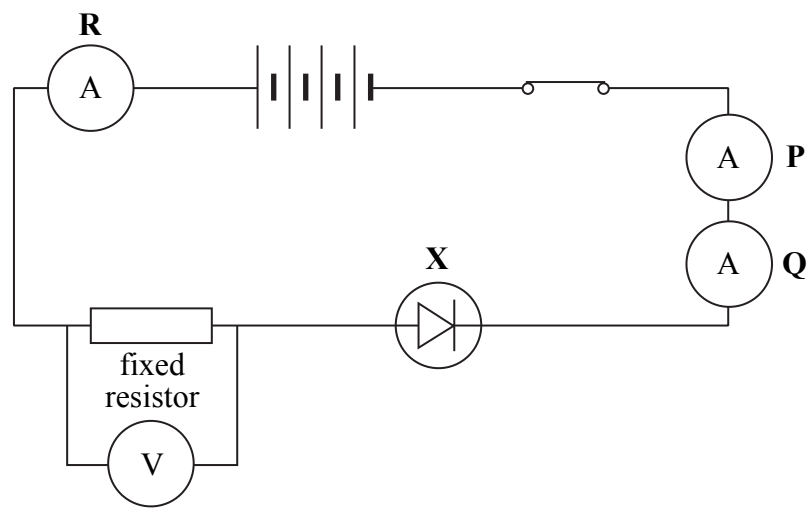

(a) Identify component X.

..... (1)

(b) State a difference between a fixed resistor and a variable resistor.

.....
 (1)

(c) (i) Complete the sentence.

The four 1.5 volt cells are called a (1)

(ii) Calculate the voltage, in volts, across the four cells.

.....
 Voltage = V (1)

(iii) The voltage across the fixed resistor is 3.8 V.
 Calculate the voltage, in volts, across the rest of the circuit.

.....
 Voltage across the rest of the circuit = V (1)



(d) The reading on ammeter **R** is 40 mA.
State the reading in milliamps on each of the other two ammeters.

ammeter **P** = mA ammeter **Q** = mA

(1)

Q9

(Total 6 marks)

Leave
blank



Leave blank

10. A child runs out in front of a truck. The driver makes an emergency stop. The graph shows the speed of the truck from the time when the driver first sees the child.

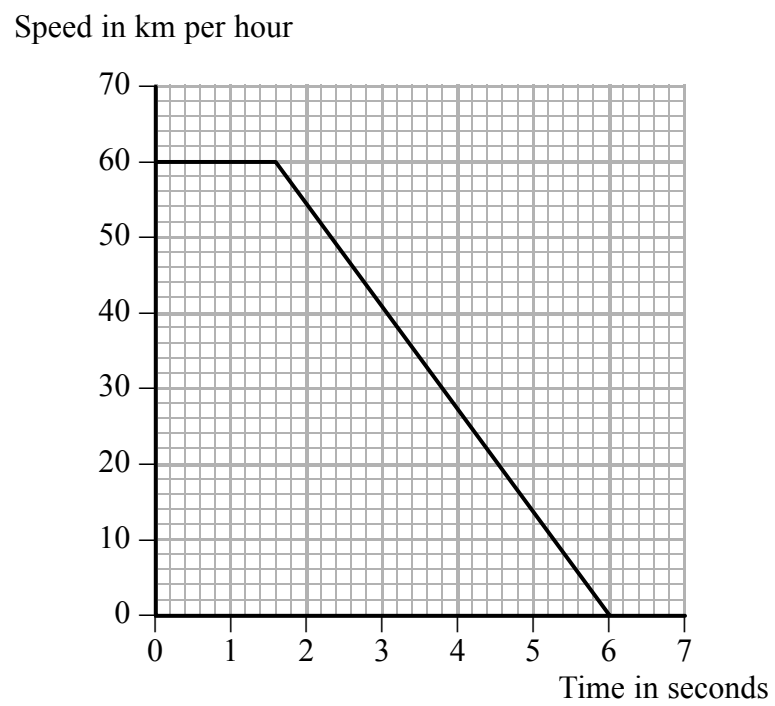

- (a) (i) State the time, in seconds, for the driver to react.

Time = s
(1)

- (ii) Calculate the time, in seconds, for the brakes to stop the truck.

Time = s
(1)

- (b) The driver had been drinking alcohol. State the effect this may have had on:

- (i) the time for the driver to react;

.....
(1)

- (ii) the time for the brakes to stop the truck.

.....
(1)



Leave
blank

- (c) Give one feature of the road conditions which may increase the stopping distance of a vehicle.

.....
(1)

- (d) The diagram shows a truck.

- (i) The centre of gravity of the truck and its load is at the point labelled C.
Add to the diagram an arrow showing the total weight.

(1)

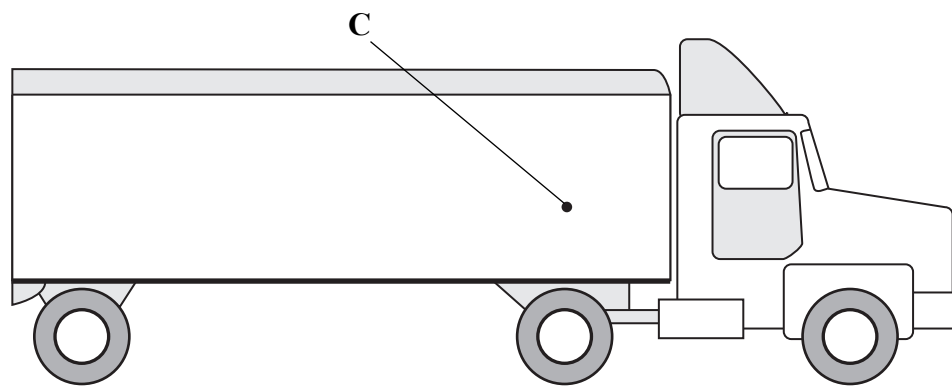

- (ii) State the name of a force which opposes the motion of the truck.

.....
(1)

Q10

(Total 7 marks)



11. The diagram shows a wave on the surface of the water of a swimming pool and a ball floating on the water.

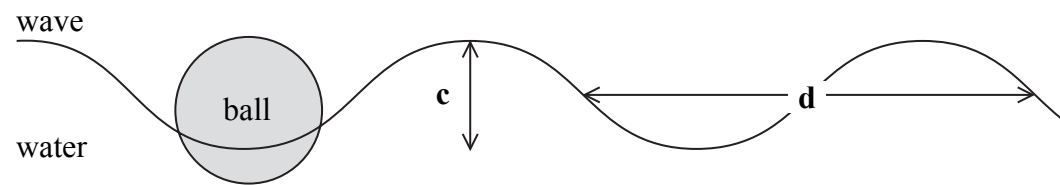

(a) Identify the features of the wave shown by:

(i) distance **c**;

..... (1)

(ii) distance **d**.

..... (1)

(b) A student observes the wave.
There are thirty complete cycles in one minute.

Calculate the frequency, in hertz, of the waves.

.....
.....

Frequency = Hz (2)

(c) (i) Identify the type of wave.

..... (1)

(ii) Describe the motion of the ball as the wave occurs.

.....
..... (1)

(Total 6 marks)

Q11



Leave
blank

12. This question is about two types of power station.
In each case complete the sentences to identify the forms of energy involved in the energy transfers.

- (a) In an oil-burning power station, oil is burned to heat water.
The water boils to give steam.
The steam spins a turbine connected to a generator.
- (i) The oil has energy. **(1)**
- (ii) The spinning turbine has energy. **(1)**
- (iii) The useful energy output from the generator is energy. **(1)**
- (b) In a hydroelectric power station, water from a high dam falls down a pipe and spins a turbine.
- (i) The useful energy transfer in the pipe is
from energy to energy. **(2)**
- (ii) Some energy is wasted as energy. **(1)**

(Total 6 marks)

Q12

17

Turn over



Leave blank

13. (a) Complete the symbol in the box to describe the nucleus of carbon-14.

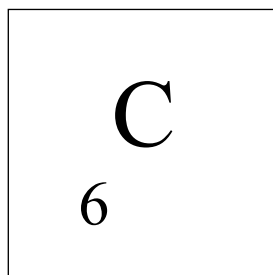

(1)

(b) The atomic number of carbon is 6.
Complete the sentence.

The atomic number is the number of in the
.....

(1)

(c) Complete the sentence.

Carbon-12 and carbon-14 are of carbon.

(1)

(d) Alpha, beta and gamma are ionising radiations.
Complete the sentences.

(i) The two which are particles are and

(1)

(ii) Ionising radiations are emitted from unstable nuclei in a radioactive decay
process which is

(1)

Q13

(Total 5 marks)



14. A student wraps an insulated wire around a large iron nail. She removes the insulation from the ends of the wire. Then she connects the wire in the circuit shown.

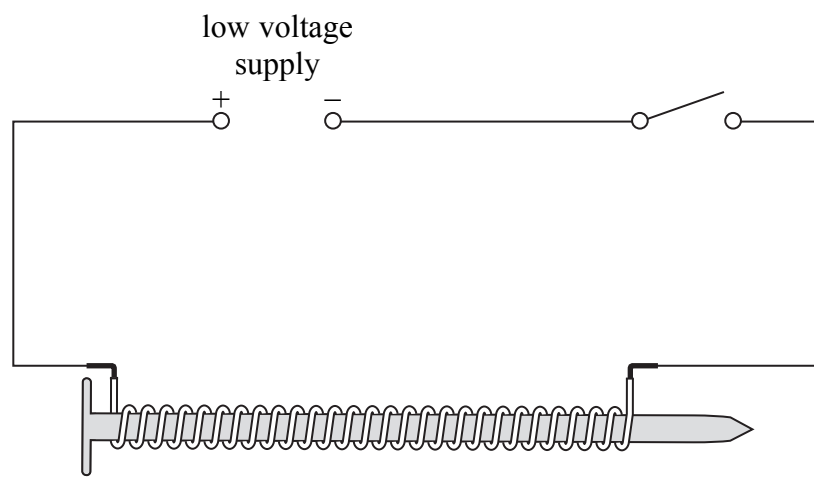

(a) State the name of the device which the student has made.

..... (1)

(b) Explain why the student uses insulated wire.

.....
.....
..... (2)

(c) (i) Explain how the student can show that the device works.

.....
..... (1)

(ii) Explain how the student can use the device to show that iron is a magnetically soft material.

.....
..... (1)

(Total 5 marks)

Q14



BLANK PAGE



Leave
blank

15. A balloon is rubbed with a dry cloth on a dry day.
The balloon then sticks to a wall.
This is because the balloon has gained negative charge.

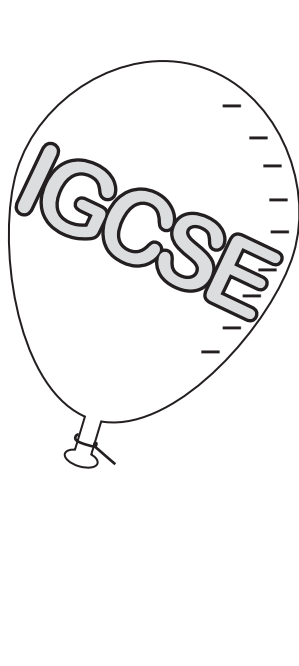

Complete the following sentences.

- (a) As the balloon is rubbed, are transferred
from the to the
by (3)
- (b) The surface of the wall near to the balloon has a charge.
This is because objects with charges attract each other. (2)

(Total 5 marks)

Q15



16. The diagram shows a large irregular-shaped block of ice floating in the sea.

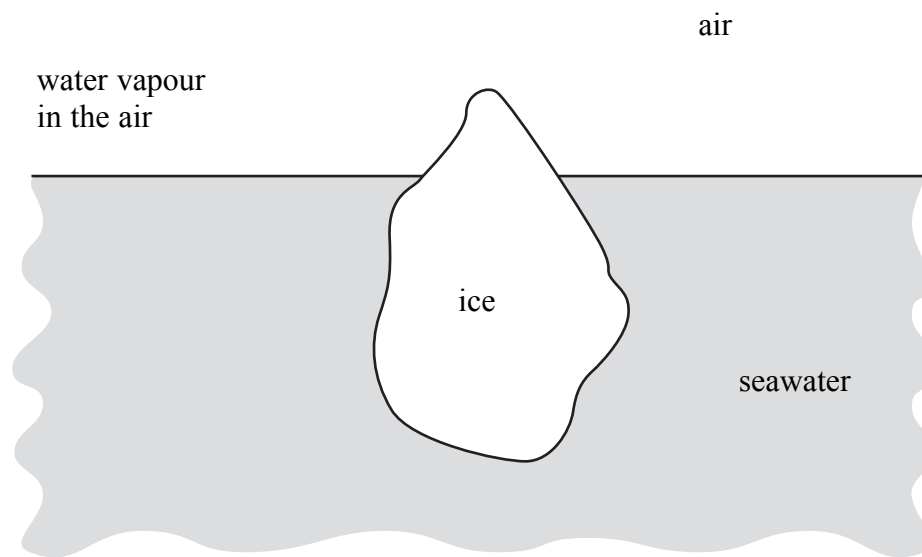

(a) Everything is made of particles.

Which label in the diagram fits the description in the following box?

The particles vibrate about fixed positions within a close-packed regular structure.

Put a cross in the correct box.

- A air
 - B ice
 - C seawater
 - D water vapour in the air
- (1)**

(b) Complete the sentences.

(i) The ice changes to water by the process of **(1)**

(ii) Water molecules in the sea usually become water molecules in the air by the process of **(1)**



(c) Complete the sentence.

In a liquid, the particles are in a irregular structure
and their motion is

(2)

Q16

(Total 5 marks)

TOTAL FOR PAPER: 100 MARKS

END

Leave
blank



BLANK PAGE

