

FORMULAE

You may find the following formulae useful.

$$\text{power} = \frac{\text{work done}}{\text{time taken}}$$

$$P = \frac{W}{t}$$

$$\text{power} = \frac{\text{energy transferred}}{\text{time taken}}$$

$$P = \frac{W}{t}$$

$$\text{frequency} = \frac{1}{\text{time period}}$$

$$f = \frac{1}{T}$$

Where necessary, assume the acceleration of free fall, $g = 10 \text{ m/s}^2$.



1. (a) A student walks from home to a library, waits to collect a book and then runs to a friend's house. The distance-time graph for the student is shown. Three sections of the graph are labelled **P**, **Q** and **R**.

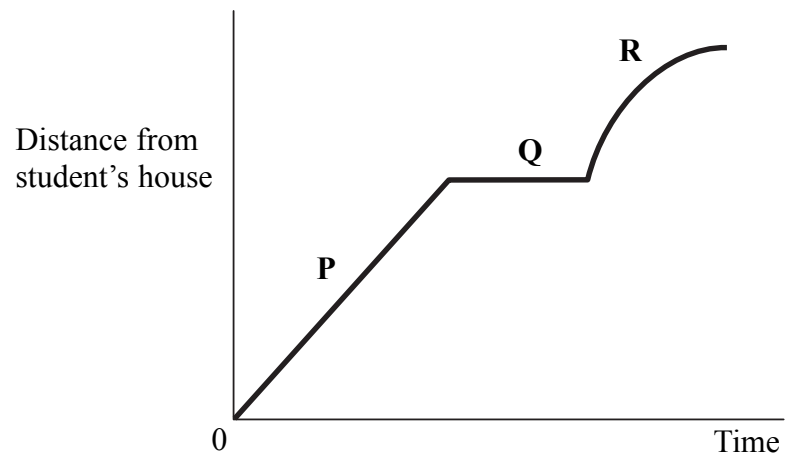

Complete the sentences with **P**, **Q** or **R**.

- (i) The student is walking at constant speed in section (1)
- (ii) The student is waiting at the library in section (1)
- (iii) The two sections of the graph that take equal amounts of time are and (1)

- (b) Use words from the box to complete the sentences. You may use each word once, more than once or not at all.

curved horizontal sloping straight

- (i) My answer to (a)(i) is because the section of the graph is and (2)
- (ii) My answer to (a)(ii) is because the section of the graph is (1)
- (c) How does the graph show that the student's friend lives nearer to the library than the student does? (1)

(Total 7 marks)

Q1



2. (a) The diagram shows the inside of a three-pin plug.

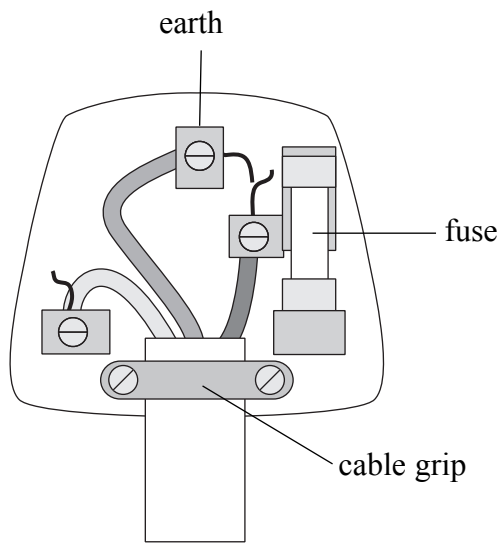

The cable is secured by the grip so that it cannot be pulled out of the plug.

Use words from the box to complete the sentences.

frayed high long thick

(i) Cables connected to plugs should not be too (1)

(ii) They should also not be (1)

(b) Describe the fault in the wiring of this plug.
..... (1)



Leave
blank

(c) A plug is fitted with a 5 A fuse and connected to a small radio with a plastic casing.

Explain

(i) why an earth wire is not needed,

.....

.....

(1)

(ii) why the fuse is unlikely to blow.

.....

.....

(1)

(d) Fuses and earth wires provide protection when faults develop in electrical equipment.
Name **one** other electrical safety device.

.....

(1)

Q2

(Total 6 marks)



3. (a) Use words from the box to complete the sentence.

energy hertz information speed time

Waves may transfer and
without transferring matter.

(2)

(b) The diagram shows a wave and five measurements A, B, C, D and E.

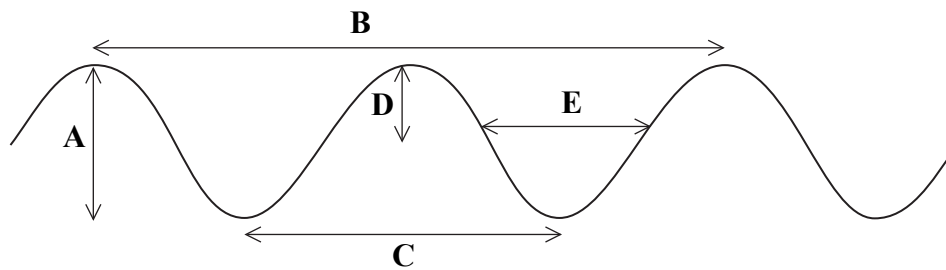

Complete the sentence by adding the correct letters.

The amplitude is represented by and the wavelength is represented
by

(2)

(c) Complete the sentences.

(i) Frequency is the number of per

(2)

(ii) To calculate frequency the two quantities needed are the wavelength and the
.....

(1)



Leave
blank

(d) The type of wave shown in (b) is a transverse wave.

(i) Sound waves are a different type of wave. Name this type of wave.

.....
(1)

(ii) Draw a circle around the range of frequencies that a human can hear.

0 Hz – 20 Hz 10 Hz – 10 000 Hz 20 Hz – 20 000 Hz
(1)

(iii) Complete the sentence with a phrase from the box.

less than the same as greater than

The hearing range for an elderly person is
that for a teenager.

(1)

Q3

(Total 10 marks)



4. (a) The diagram shows a loudspeaker.

A loudspeaker is a device which usefully transfers electrical energy to sound energy.

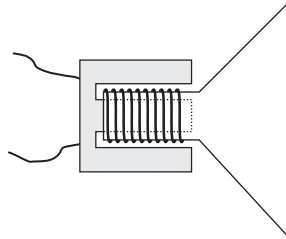

State the name of a device for each of the following useful energy transfers.

(i) Sound energy to electrical energy

..... (1)

(ii) Electrical energy to thermal (heat) energy

..... (1)

(b) Give an example of the transfer of gravitational potential energy to kinetic energy.

..... (1)

(c) When a car moves, some of the chemical energy of the petrol is transferred to the kinetic energy of the car.



State **one** other form of energy that the chemical energy is transferred to.

..... (1)



Leave blank

(d) Use phrases from the box to complete the sentence.

total energy input	total energy output
useful energy input	useful energy output

For the car in (c), energy is conserved.

The statement 'energy is conserved' means that the

.....is equal to the

.....

(2)

(e) Electricity can be generated using wind power. Complete the boxes below to show the energy transfers involved.

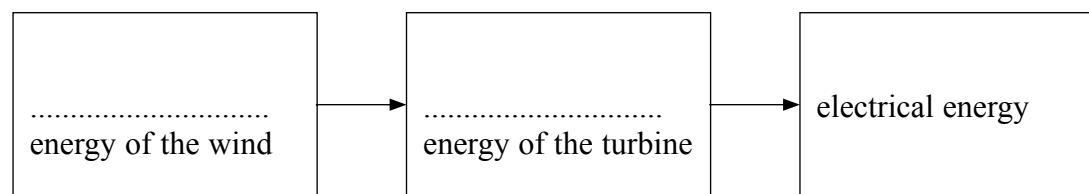

(2)

Q4

(Total 8 marks)



Leave blank

5. (a) The activity of a radioactive source is measured in becquerels (Bq).

(i) How many becquerels are there in 100 kBq?

100 kBq =Bq
(1)

(ii) A source has an activity of 100 kBq. How many of its atoms decay in 5 seconds?

Number of atoms =
(2)

(b) A teacher uses a Geiger-Müller tube to measure background radiation. The background reading is 70 counts per minute. When a radioactive source is placed in front of the Geiger-Müller tube the reading increases to 400 counts per minute.

(i) Calculate the number of counts per minute due to the radioactive source.

Counts per minute =
(2)

(ii) The source has a very short half-life and quickly decays so that the reading after two hours is 60 counts per minute. Complete the sentences

1. This reading is due only to
.....

2. The readings show that background count is
.....
(2)

(c) State **two** sources of background radiation.

1

2
(2)

(Total 9 marks)

Q5



Leave blank

6. (a) The box gives the colours in the visible spectrum in order.
Add the names of the missing colours.

red orange blue indigo violet

(2)

- (b) The box gives three adjacent parts of the electromagnetic spectrum.

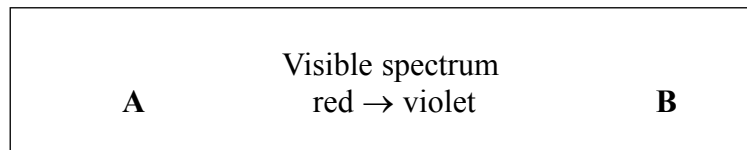

- (i) State the names of

part **A**

part **B**

(2)

- (ii) Which part, **A** or **B**, has the higher frequency?

.....
(1)

Q6

(Total 5 marks)



7. (a) The diagram shows an analogue signal and a digital signal.



analogue



digital

Complete the sentences.

(i) Analogue signals vary (1)

(ii) Digital signals have only two values which are and (1)

(b) The diagram below shows a binary code and part of its digital signal.



digital signal

0 1 0 0 1 1 1 0 1

binary code

Draw suitable lines to complete the digital signal.

(3)

(c) State **one** advantage of using a digital signal system rather than an analogue signal system.

..... (1)

Q7

(Total 6 marks)



Leave
blank

8. (a) Complete the sentence below.

A substance changes state from liquid to gas. This process is called

.....

(1)

(b) The box shows the motion and structure of four particles in a gas.

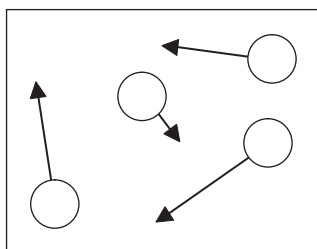

In the box below, show the motion and structure of four particles in a liquid of the same substance.



(3)

Q8

(Total 4 marks)



9. (a) A child runs out in front of a car. The driver makes an emergency stop. The graph shows the speed of the car from the time when the driver sees the child on the road.

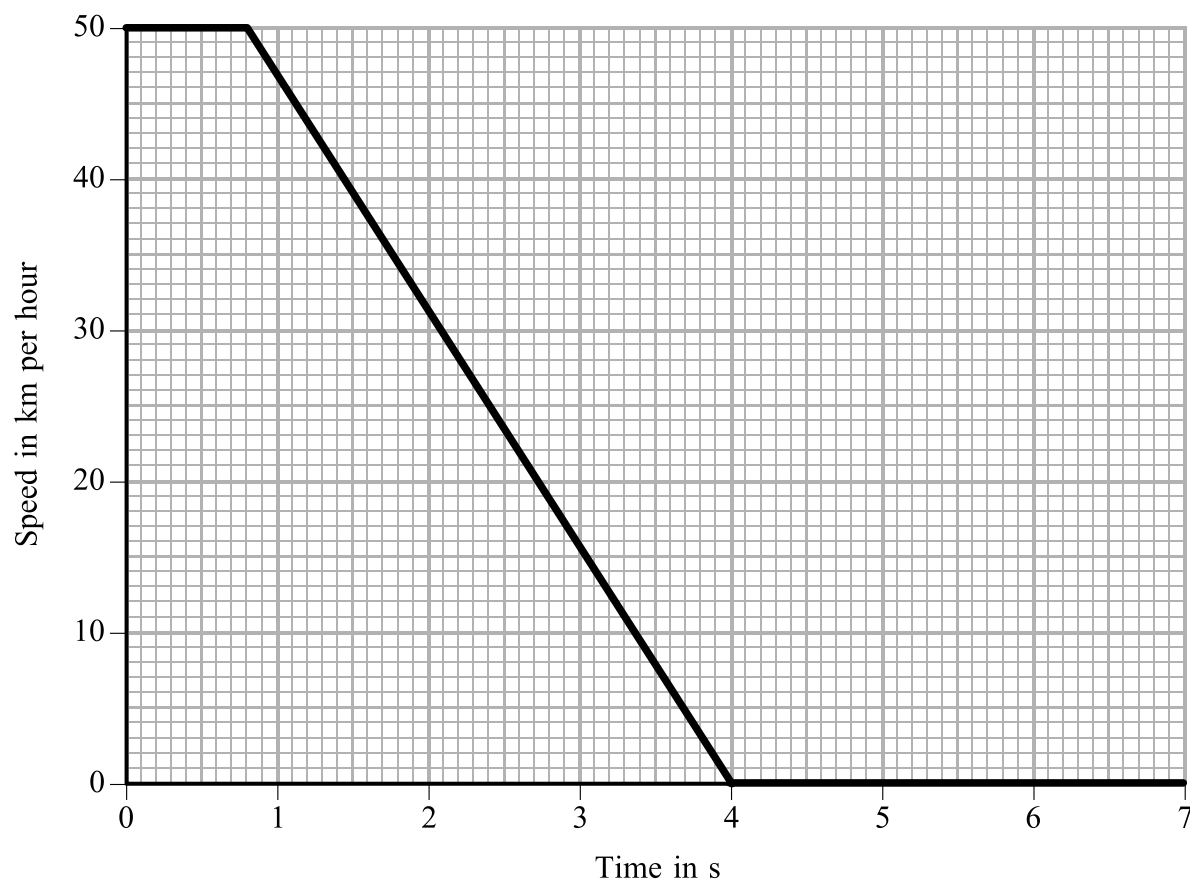

(i) State the driver's reaction time in seconds.

Time = s
(1)

(ii) State the time in seconds for the brakes to stop the car.

Time = s
(1)

(iii) Draw **two** more lines on the grid above to show how the speed might change if the driver has been drinking alcohol **and** the road is slippery.

(2)



Leave
blank

(b) The condition of the tyres and the condition of the road surface are two factors which affect the force of friction on a car.

(i) Name **one** other factor which affects the force of friction on a car.

.....
(1)

(ii) The diagram shows a car. The centre of gravity of the car is at the point labelled **X**.

Add to the diagram an arrow showing the weight of the car.

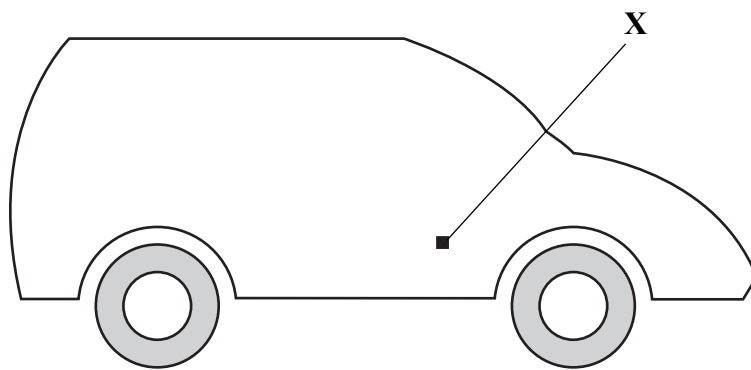

(1) Q9

(Total 6 marks)



10. Parts of the electromagnetic spectrum have various uses.

(a) Which part is used for

(i) heaters and night vision equipment,

..... (1)

(ii) sterilising food and medical equipment?

..... (1)

(b) All the parts of the electromagnetic spectrum are transverse waves.

(i) State **one** property which all the parts have in common but which is **not** shared with other waves.

..... (1)

(ii) Give **one** example of a transverse wave which is **not** part of the electromagnetic spectrum.

..... (1)

(iii) Complete the sentence below.

In a transverse wave, each point on the wave is moving in a direction which is to the direction in which the of the wave is moving.

(2) Q10

(Total 6 marks)



11. A student connects a light dependent resistor (LDR) to a battery.

(a) The current in the LDR is 0.050 A and its resistance is 90 Ω in the dark.

(i) State the equation which relates current, resistance and voltage.

.....

 (1)

(ii) Calculate the voltage across the LDR. Show your working and give the unit.

.....

 Voltage =
 (2)

(b) The LDR is moved to a position in the light.

Choose words from the box to complete the table.
 You may use each word once, more than once or not at all.

decrease	increase	stay the same
----------	----------	---------------

Effect on ...	It will ...
the resistance of the LDR	
the current in the LDR	

(2) Q11

(Total 5 marks)



12. (a) The diagram shows how a student connects several components in a circuit. The student uses four identical 1.5 volt cells.

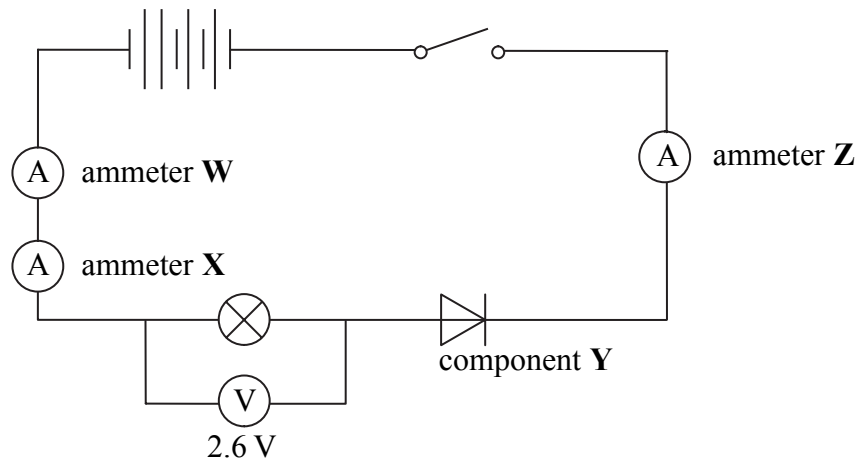

(i) Identify component **Y**.

..... (1)

(ii) The reading on ammeter **Z** is 50 mA.

What is the reading in milliamps on each of the other two ammeters?

ammeter **W** = mA ammeter **X** = mA (1)

(iii) The student expected the lamp to be brighter and the reading on the voltmeter to be 6.0 V.

The voltmeter is working correctly.

Give **two** reasons why the reading on the voltmeter is less than 6.0 V.

1 (1)

2 (1)



Leave blank

(b) The graph shows how the current in a filament lamp varies with the voltage across it.

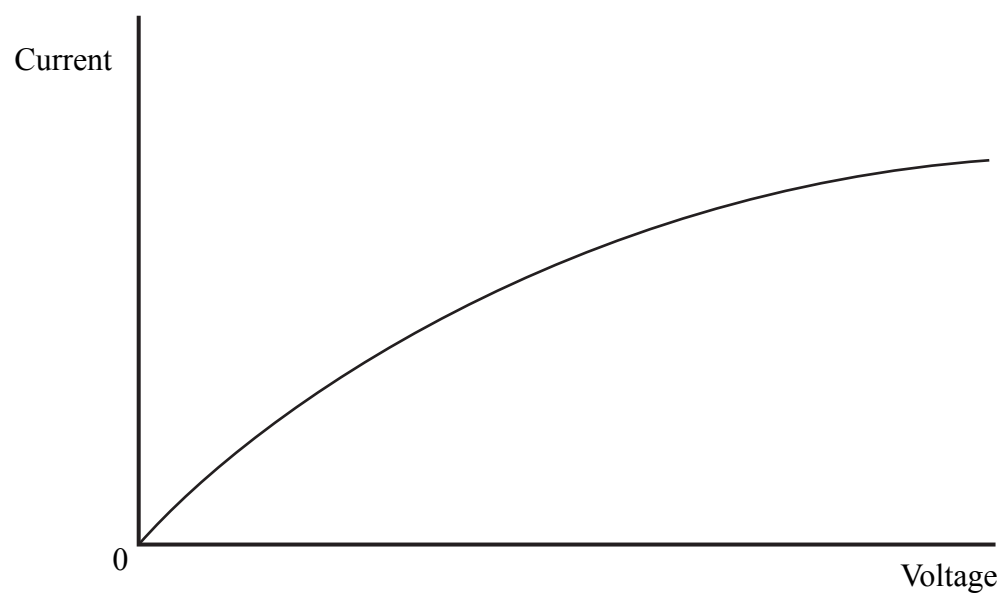

Explain why the graph is not a straight line.

.....

.....

.....

.....

.....

(3)

Q12

(Total 7 marks)



13. (a) The kelvin scale of temperature starts at the absolute zero of temperature.

(i) Describe the motion of all molecules at absolute zero.

.....
.....

(1)

(ii) What temperature in degrees Celsius is equal to absolute zero?

..... °C
(1)

(iii) What temperature in kelvin is equal to 100 °C?

..... K
(1)

(b) Read the following passage.

In 1827 Robert Brown, a Scottish botanist, was using a microscope to view a suspension of pollen grains in water. He noticed that the grains were moving about randomly. At first he thought that this might be caused by life hidden within the pollen grains. However when he studied particles of dye in water, he found the same erratic motion. Robert Brown could not explain the movement of the particles. However, because he was the first person to describe the movement, it is now called Brownian motion.

How do scientists now explain Brownian motion?

.....
.....
.....
.....

(3)

Q13

(Total 6 marks)



14. (a) When you rub a polythene rod with a woollen cloth the rod becomes negatively charged.

(i) Complete the labels on the diagram.

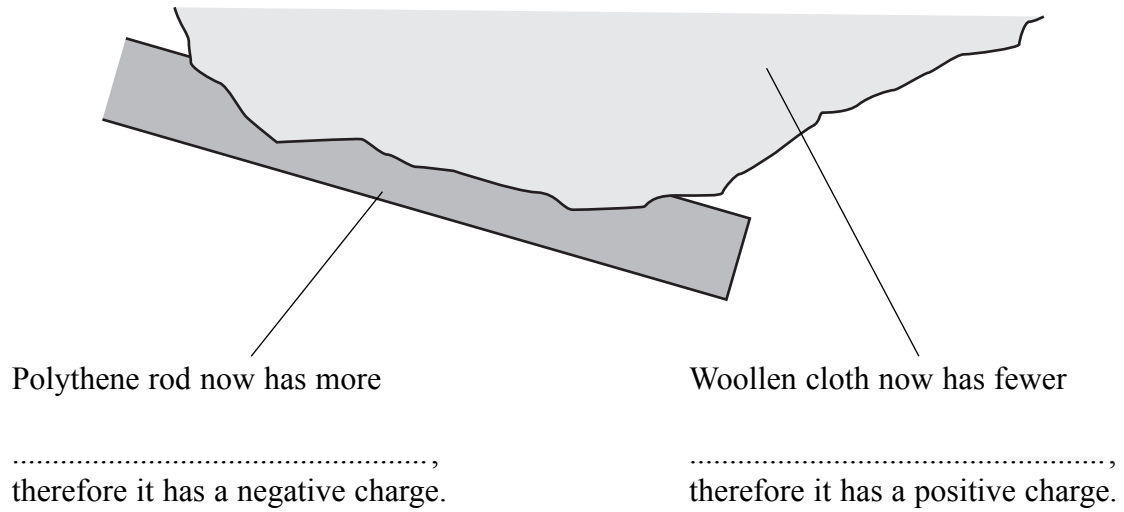

(1)

(ii) Explain why the polythene rod then remains negatively charged for some time.

.....
.....
.....

(2)

(iii) If you rub a copper rod rather than a polythene rod, the copper rod will not stay charged.
Why not?

.....
.....

(1)

(b) Complete the following.

When a petrol tanker is filled or emptied the build-up of charge can be dangerous.

This is because a may occur and this can ignite the petrol vapour and cause an explosion.

(1)

Q14

(Total 5 marks)



Leave blank

15. (a) The graph shows how the activity of a radioactive isotope varies with time.

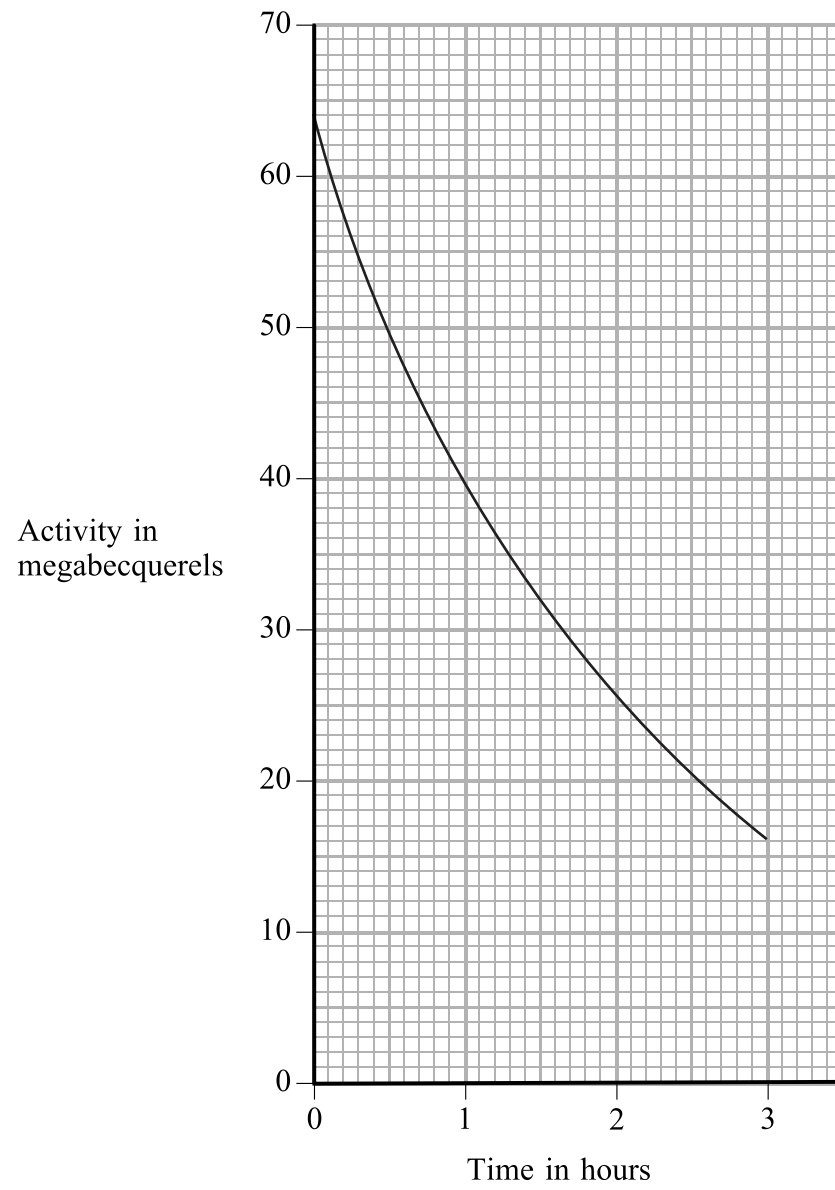

On the graph, show how you can estimate the half-life of this radioactive isotope. Give your estimate in minutes.

Half-life = minutes
(3)

(b) A radioactive isotope is used as a medical tracer in the human digestive system.

Explain briefly how the tracer is used.

.....
.....
.....

(2)

Q15

(Total 5 marks)



16. (a) Complete the sentence.

Voltage is across a copper coil when a changes through the coil.

(2)

(b) A transformer is used to change the size of an alternating voltage.

Complete the equation for a transformer.

$$\frac{\text{input (primary) voltage}}{\text{output (secondary) voltage}} = \frac{\quad}{\quad}$$

(1)

(c) Transformers are used in the large-scale transmission of electrical energy. Choose phrases from the box to complete the sentences. You may use each phrase once, more than once or not at all.

- in the pylons**
- in the transmission line**
- in the turbine**
- just after the transmission line**
- just before the generator**
- just before the transmission line**

(i) In the transmission system a step-up transformer must be located

.....

(1)

(ii) In the transmission system a step-down transformer must be located

.....

(1)

Q16

(Total 5 marks)

TOTAL FOR PAPER: 100 MARKS

END



BLANK PAGE

