

Centre No.							Surname		Initial(s)
							Signature		
Candidate No.									

Paper Reference(s)

**4420/1F**

Examiner's use only

--	--	--

**London Examinations IGCSE**

Team Leader's use only

--	--	--

**Physics**

Paper 1F

**Foundation Tier**

Wednesday 31 October 2007 – Morning

Time: 1 hour 30 minutes

**Materials required for examination**

Nil

**Items included with question papers**

Nil

Question Number	Leave Blank
1	
2	
3	
4	
5	
6	
7	
8	
9	
10	
11	
12	
13	
14	
15	
Total	

**Instructions to Candidates**

In the boxes above, write your centre number and candidate number, your surname, initial(s) and signature.

The paper reference is shown at the top of this page. Check that you have the correct question paper.

Answer **ALL** the questions in the spaces provided in this question paper.

Show all the steps in any calculations and state the units.

Calculators may be used.

**Information for Candidates**

The marks for individual questions are shown in round brackets: e.g. (2).

There are 15 questions in this question paper. The total mark for this paper is 100.

There are 24 pages in this question paper. Any blank pages are indicated.

Useful formulae are given on page 2.

**Advice to Candidates**

Write your answers neatly and in good English.

This publication may be reproduced only in accordance with Edexcel Limited copyright policy. ©2007 Edexcel Limited.

Printer's Log. No.  
**H28021A**  
W850/U4420/57570 4/5/6/2/1



*Turn over*



## FORMULAE

You may find the following formulae useful.

$$\text{power} = \frac{\text{work done}}{\text{time taken}}$$

$$P = \frac{W}{t}$$

$$\text{power} = \frac{\text{energy transferred}}{\text{time taken}}$$

$$P = \frac{W}{t}$$

$$\text{frequency} = \frac{1}{\text{time period}}$$

$$f = \frac{1}{T}$$

Where necessary, assume the acceleration of free fall,  $g = 10 \text{ m/s}^2$ .



1. (a) The box lists the colours of the visible spectrum in order of decreasing wavelength.

Write the names of the **two** missing colours on the dotted lines.

.....
orange
yellow
green
blue
indigo
.....

(2)

(b) The box below lists radiations in the electromagnetic spectrum.

radio waves
microwaves
infra-red radiation
visible light
ultraviolet light
X-rays
gamma radiation

Tick (✓) the correct ending for each sentence.

(i) From top to bottom in the list, the wavelength

decreases	<input type="checkbox"/>
increases	<input type="checkbox"/>
stays the same	<input type="checkbox"/>

(1)

(ii) From top to bottom in the list, the frequency

decreases	<input type="checkbox"/>
increases	<input type="checkbox"/>
stays the same	<input type="checkbox"/>

(1)

(iii) From top to bottom in the list, the speed

decreases	<input type="checkbox"/>
increases	<input type="checkbox"/>
stays the same	<input type="checkbox"/>

(1)

(Total 5 marks)

Q1



2. (a) Electrical heating is used in different ways, for example in an electric kettle.

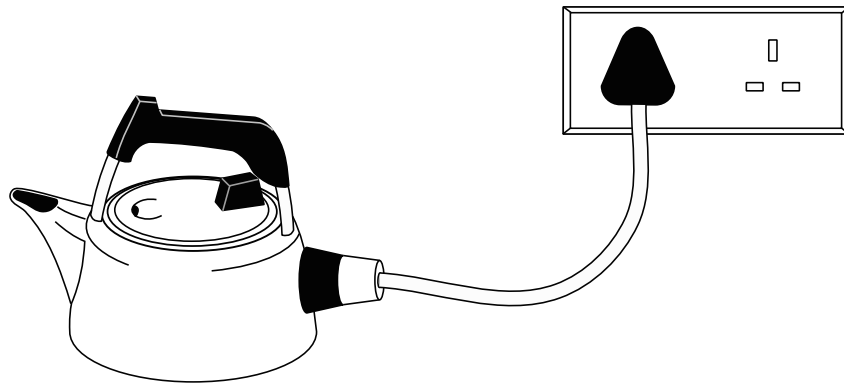

Give **two** other examples of devices which use electrical heating.

1 .....

2 .....

(2)

(b) Electricity can be dangerous. Safety features such as fuses are often used.

Give **two** other examples of electrical safety features.

1 .....

2 .....

(2)

(c) Explain why it is dangerous to touch an electric socket when your hands are wet.

.....  
.....  
.....

(2)

(d) A small object is stuck in an electric socket. Explain why it is dangerous to use a metal screwdriver to remove it.

.....  
.....  
.....

(2)

(Total 8 marks)

Q2



3. (a) An electric drill transfers some of its electrical energy input to kinetic energy.

Complete the flow diagram.

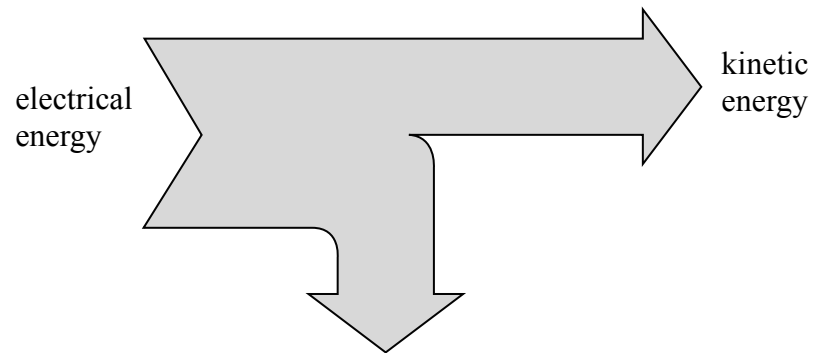

energy wasted as

..... and .....

(2)

(b) Complete the equation for efficiency.

$$\text{efficiency} = \frac{\text{energy output}}{\text{total energy input}}$$

(1)

(c) (i) A tractor uses diesel as its fuel. What type of energy is stored by this fuel?

..... (1)

(ii) A nuclear power station uses uranium as its fuel. What type of energy is stored by this fuel?

..... (1)

(d) (i) Give an example of a device or system which stores energy as elastic potential energy.

..... (1)

(ii) Give an example of a device or system which stores energy as gravitational potential energy.

..... (1)

(Total 7 marks)

Q3



4. (a) The distance–time graph shows a journey which a cyclist makes between two villages.

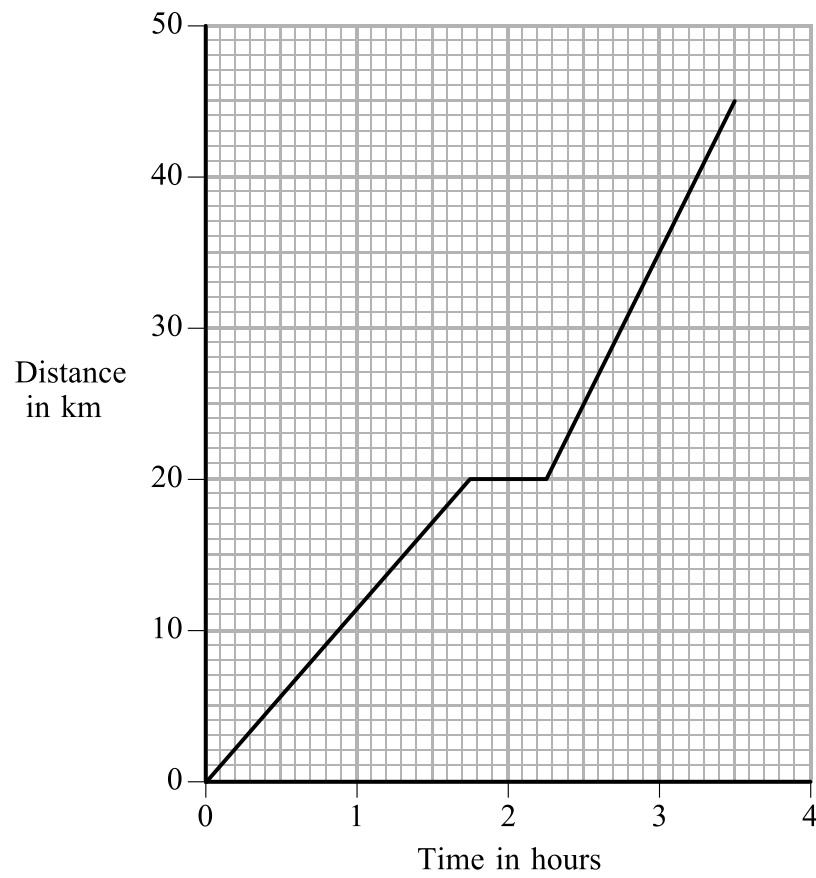

(i) How long in hours does the whole journey take?

Time = ..... hours  
(1)

(ii) For how long in hours does the cyclist rest during her journey?

Time = ..... hours  
(1)

(iii) What is the distance in kilometres between the villages?

Distance = ..... km  
(1)

(iv) The cyclist's average speed is greater after her rest than before her rest.

How can you tell this from the graph?

.....  
.....

(2)



(b) (i) State the equation which relates average speed, distance moved and time taken.

.....  
(1)

(ii) What is the unit of speed when distance moved is measured in metres and time taken is measured in seconds?

.....  
(1)

**(Total 7 marks)**

Leave  
blank

**Q4**



5. (a) A fluid is either a liquid or a gas. The diagram shows a fluid which is at rest in a tank. **X** is a point in the fluid.

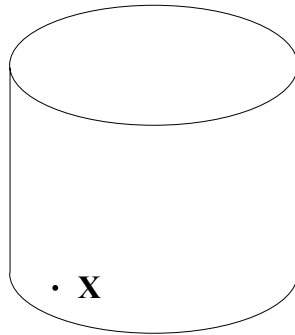

Tick (✓) the correct ending for each sentence.

- (i) When the fluid is a gas the pressure at **X** acts

equally in all directions	<input type="checkbox"/>
mostly downwards	<input type="checkbox"/>
mostly sideways	<input type="checkbox"/>
mostly upwards	<input type="checkbox"/>

(1)

- (ii) When the fluid is a liquid the pressure at **X** acts

equally in all directions	<input type="checkbox"/>
mostly downwards	<input type="checkbox"/>
mostly sideways	<input type="checkbox"/>
mostly upwards	<input type="checkbox"/>

(1)

- (b) State the equation which relates area, force and pressure.

.....

(1)

- (c) Complete the table.

Quantity	Name of unit	Symbol for unit
force	newton	N
area		
pressure		

(4)





Leave blank

(d) A student sits normally. Then he rocks back on his chair.

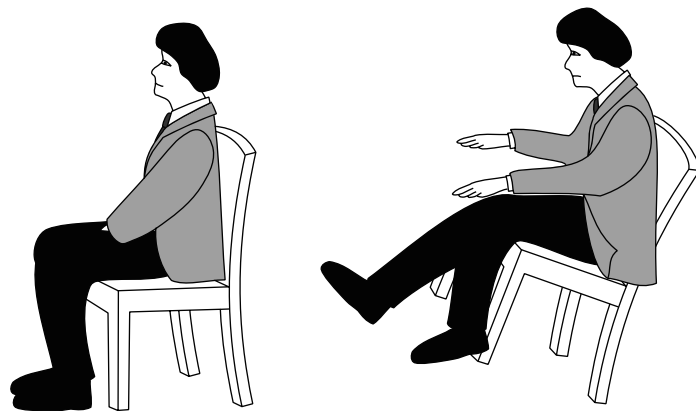

Use the words **area**, **force** and **pressure** to explain how the pressure on the floor changes.

.....

.....

.....

.....

(3)

Q5

(Total 10 marks)



6. (a) Use words from the box to complete the sentences.

<b>electrons</b>	<b>isotopes</b>	<b>neutrons</b>	<b>pressure</b>
<b>protons</b>	<b>temperature</b>	<b>time</b>	

(i) The activity of radioactive sources decreases with ..... (1)

(ii) Half-life is different for different ..... (1)

(b) A mineral is radioactive. In October 1957 the mineral had an activity of 80 000 becquerels. In October 2007 its activity was 40 000 becquerels.

(i) Calculate the half-life in years of the mineral.  
.....  
Half-life = ..... years (1)

(ii) Predict the month and year when the activity of the mineral will be 20 000 becquerels.  
..... (1)

(iii) What is the symbol for the unit **becquerel**?  
..... (1)

(c) Use words from the box to complete the sentence.

<b>computers</b>	<b>radiotherapy</b>	<b>specimens</b>	<b>television</b>	<b>tracers</b>
------------------	---------------------	------------------	-------------------	----------------

Radioactivity is used in medical and non-medical ....., in dating archaeological ..... and in ..... (3)

(Total 8 marks)

Q6



7. (a) (i) Name the space around a magnet where its magnetism can be detected.

.....  
(1)

(ii) The diagram shows some magnetic field lines around a bar magnet.  
Write **N** and **S** on the bar magnet to show the position of its poles.

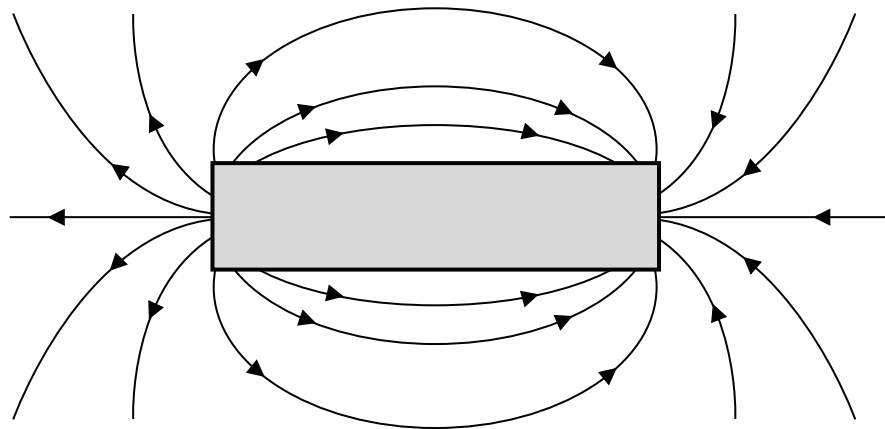

(1)

(iii) On the diagram below, draw some magnetic field lines in the space between the ends of two bar magnets.



(2)

(b) Seven materials were placed in a magnetic field. Their names are in the box.  
Magnetism was induced in only one of them. Underline its name.

aluminium    brass    copper    silver    steel    tin    tungsten

(1)

Q7

(Total 5 marks)



**BLANK PAGE**



Leave  
blank

8. Use words from the box to complete the sentences. You may use each word once, more than once or not at all.

attraction	electrons	friction	gravity	metals
neutrons	plastics	protons	repulsion	

Materials which do not conduct electricity, such as ..... are known as insulators. They may be charged by .....

Positive charge on a material is due to ..... being removed from its surface and negative charge is due to ..... being added to its surface.

The forces between unlike charges are forces of .....

Q8

(Total 5 marks)

13

Turn over



9. (a) Complete the sentence.

Hooke's law states that a force acting on a material produces an extension which is ..... to the force.

(1)

(b) A student attaches a load to the end of a spring.

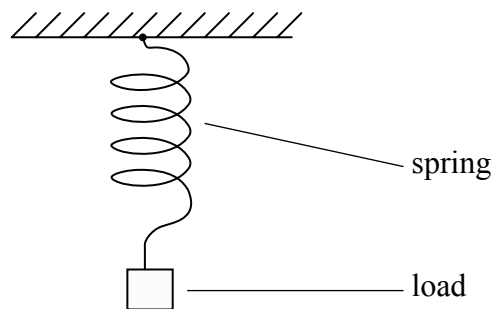

(i) Name the type of force acting in the stretched spring.

..... (1)

(ii) The student measured the length of the spring for different loads. The table shows her data.

Load (N)	0	1.0	2.0	3.0	4.0	5.0	6.0
Length of spring (mm)	30	70	110	150	190	250	320

1. Deduce the load in newtons that would produce a length of 130 mm.

Load = ..... N (1)

2. Estimate the maximum load in newtons at which the spring obeys Hooke's law.

Maximum load = ..... N (1)



(c) A force–extension graph for a material is shown. Three regions **A**, **B** and **C** are labelled.

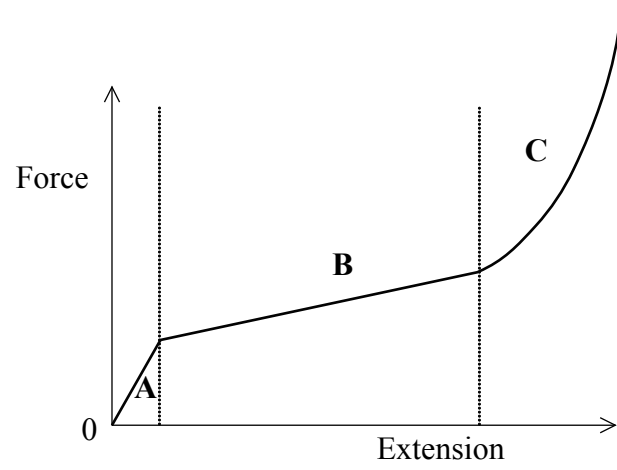

(i) In which region is Hooke's law obeyed?

.....  
(1)

(ii) In which region is the material easiest to extend?

.....  
(1)

(iii) Explain your answer to (ii).

.....  
.....  
.....  
(1)

(Total 7 marks)

Q9



10. A circuit contains a resistor **R**, a thermistor and a buzzer connected to a cell as shown. The circuit can be used as a simple fire alarm.

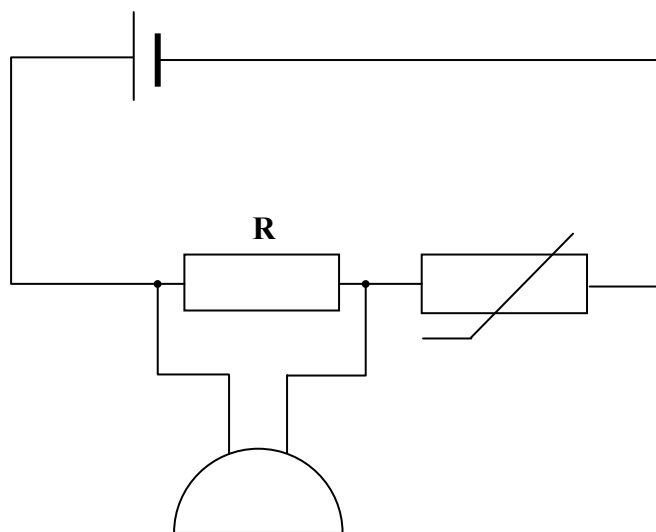

- (a) (i) Complete the sentence.  
When temperature increases, the resistance of a thermistor ..... (1)
- (ii) What happens to the current in the circuit when the temperature increases?  
..... (1)
- (b) (i) State the equation which relates voltage, current and resistance.  
..... (1)
- (ii) When temperature increases, does the voltage across **R** stay the same, increase or decrease?  
..... (1)
- (iii) Explain your answer.  
.....  
..... (2)





(c) The buzzer starts to sound when the voltage across **R** is a particular value. Add a voltmeter to the circuit diagram to show how this voltage is measured.

(1)

(Total 7 marks)

Leave  
blank

Q10

**QUESTION 11 IS ON THE NEXT PAGE**



11. (a) (i) Define frequency.

.....  
(1)

(ii) Define time period.

.....  
(1)

(b) A student has a heart rate of 72 beats per minute.  
Calculate

(i) the frequency of his heart beat in hertz

Frequency = ..... Hz  
(1)

(ii) the time period of his heart beat in seconds.

Time period = ..... s  
(1)

(c) Generally the heavier an animal is, the lower is its heart rate. The data in the table gives the heart rate of animals of different masses.

Mass (kg)	100	200	300	400	500	600
Heart rate (beats per minute)	63	53	48	45	42	40

(i) Use the grid opposite to plot a graph of heart rate against mass. Draw a smooth curve for your plotted points.  
(3)



Leave blank

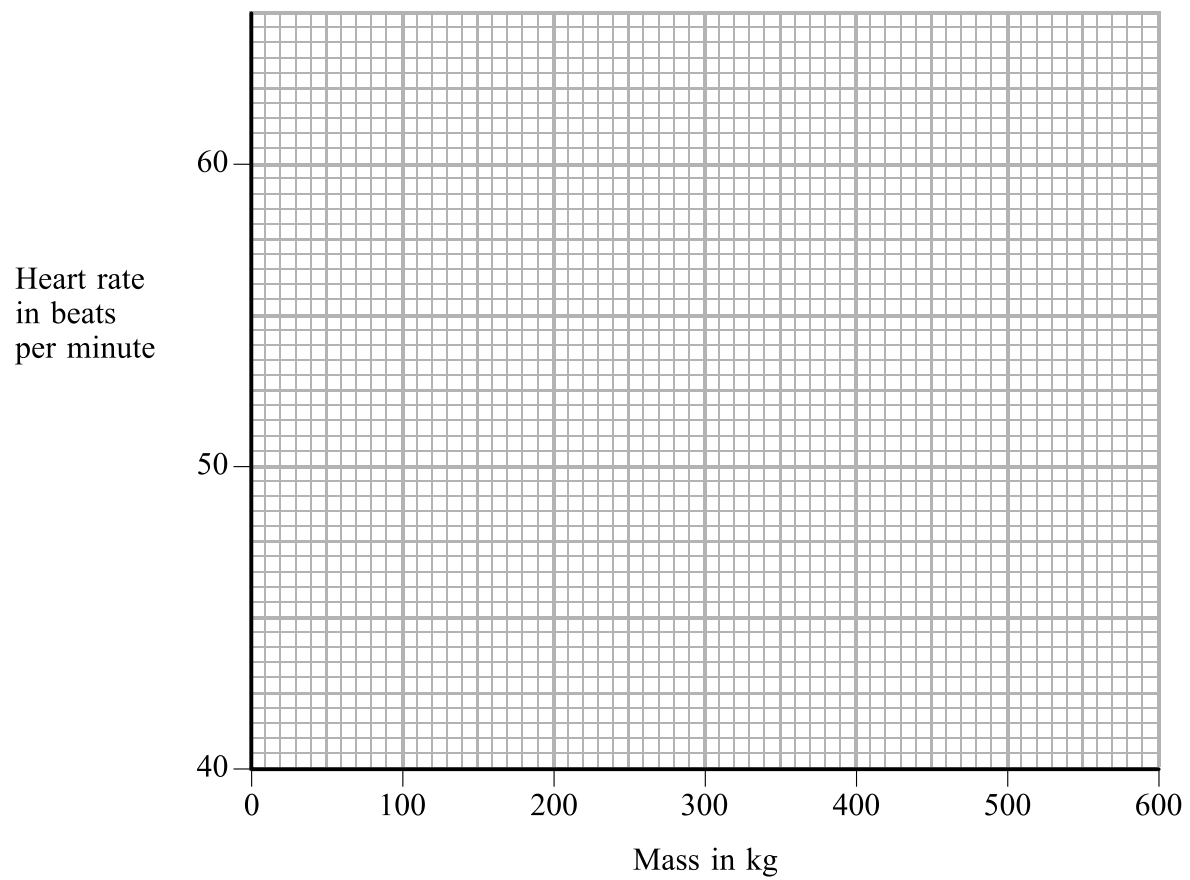

(ii) This animal has a mass of 5000 kg.

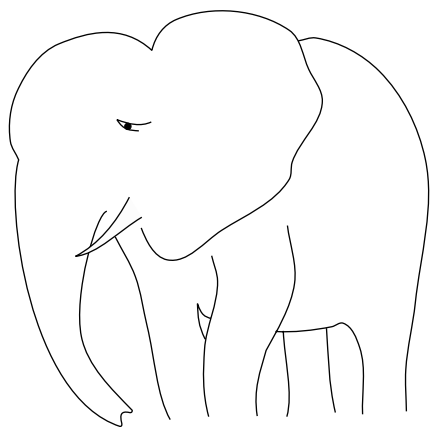

Explain why you cannot use your graph to predict the heart rate of this animal.

.....  
.....

(1) Q11

(Total 8 marks)



Leave  
blank

12. (a) Define the following terms.

(i) Atomic number

.....  
(1)

(ii) Mass number

.....  
(1)

(iii) Isotope

.....  
(1)

(b) How many of the following particles are found in a neutral atom of  ${}_{11}^{23}\text{Na}$ ?

(i) protons

.....  
(1)

(ii) neutrons

.....  
(1)

(iii) electrons

.....  
(1)

(c) Alpha, beta and gamma are three types of ionising radiation. Which one of these radiations does **not** contain any of the particles mentioned in (b)?

.....  
(1)

(d) State **one** danger of ionising radiations.

.....  
(1)

(Total 8 marks)

Q12



13. (a) Two students make a two-dimensional model of a liquid.

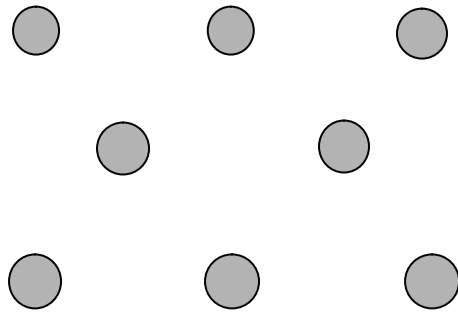

Give **one** criticism of the arrangement of the particles in this model.

.....  
.....  
**(1)**

(b) When the temperature of a liquid is raised, evaporation takes place.

(i) What happens to the particles during evaporation?

.....  
.....  
**(1)**

(ii) Describe what has happened to the position and motion of the particles after all the liquid has evaporated.

.....  
.....  
.....  
**(2)**

**(Total 4 marks)**

**Q13**



14. (a) The diagram shows a flat circular coil carrying a current. On the diagram, sketch the magnetic field pattern of the coil. Use arrows to show the direction of the magnetic field lines.

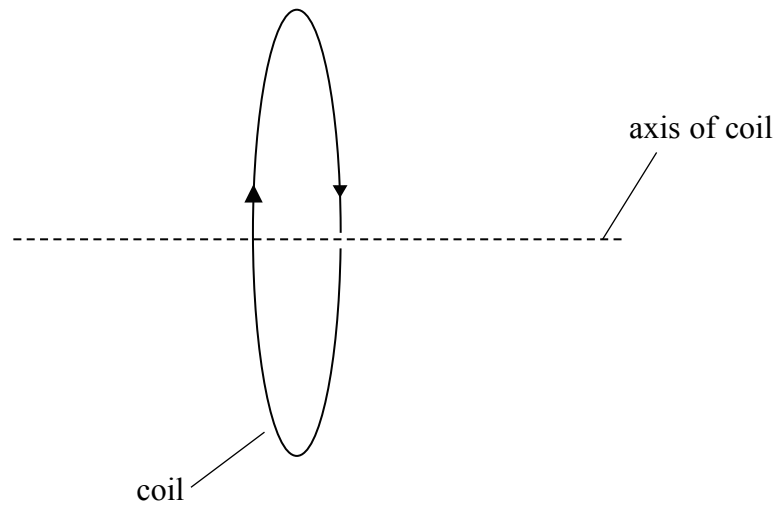

(3)

- (b) When there is a current in the coils the electromagnet shown below is able to carry small loads from a hook. When the current is switched off the hook and load fall off.

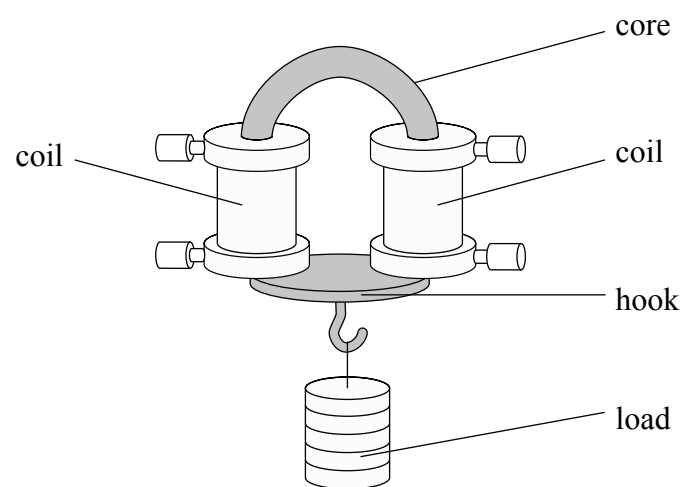

- (i) Name a suitable material for the core and the hook.

..... (1)



(ii) Explain why this material is suitable.

.....  
.....  
.....

(2)

(Total 6 marks)

Leave  
blank

Q14

**QUESTION 15 IS ON THE NEXT PAGE**



15. (a) The diagram shows a step-up transformer.

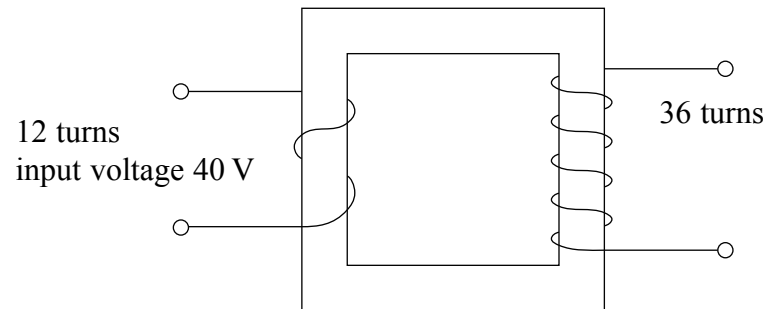

(i) Calculate the value of the output voltage.

.....  
 .....

Output voltage = ..... V  
**(3)**

(ii) Is the output voltage a.c. or d.c.?

.....  
**(1)**

(b) The diagram below shows an electricity generation and transmission system. Step-up and step-down transformers are used. On the dotted lines label these transformers **U** (step-up) or **D** (step-down).

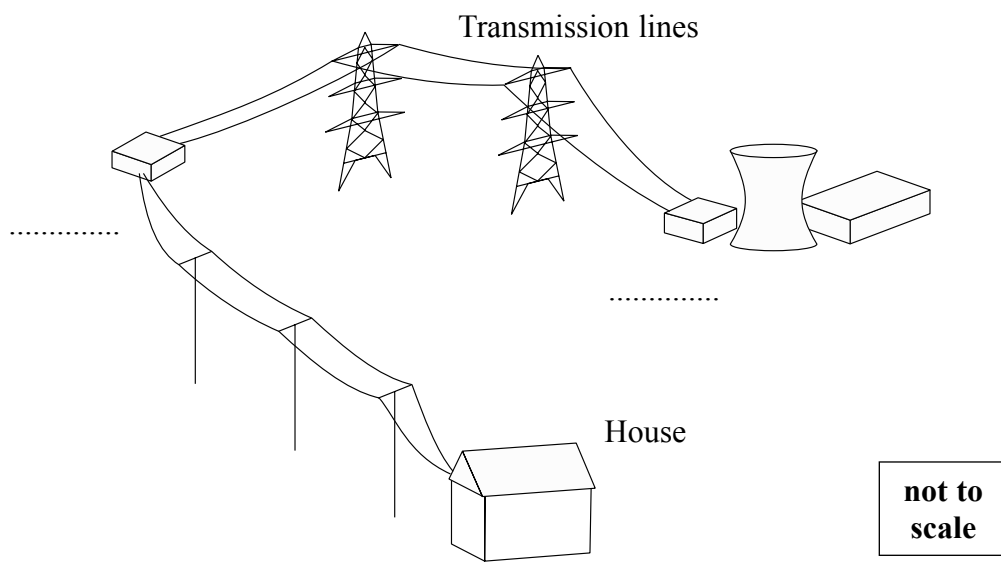

not to scale

**(1)**

**Q15**

**(Total 5 marks)**

**TOTAL FOR PAPER: 100 MARKS**

**END**

