

Please check the examination details below before entering your candidate information

Candidate surname

Other names

Centre Number

Candidate Number

--	--	--	--	--

--	--	--	--

Pearson Edexcel International Advanced Level

Time 1 hour 30 minutes

Paper
reference

WMA12/01

Mathematics

International Advanced Subsidiary/Advanced Level
Pure Mathematics P2

You must have:

Mathematical Formulae and Statistical Tables (Yellow), calculator

Total Marks

Candidates may use any calculator permitted by Pearson regulations. Calculators must not have the facility for symbolic algebra manipulation, differentiation and integration, or have retrievable mathematical formulae stored in them.

Instructions

- Use **black** ink or ball-point pen.
- If pencil is used for diagrams/sketches/graphs it must be dark (HB or B).
- **Fill in the boxes** at the top of this page with your name, centre number and candidate number.
- Answer **all** questions and ensure that your answers to parts of questions are clearly labelled.
- Answer the questions in the spaces provided – *there may be more space than you need.*
- You should show sufficient working to make your methods clear. Answers without working may not gain full credit.
- Inexact answers should be given to three significant figures unless otherwise stated.

Information

- A booklet 'Mathematical Formulae and Statistical Tables' is provided.
- There are 10 questions in this question paper. The total mark for this paper is 75.
- The marks for **each** question are shown in brackets – *use this as a guide as to how much time to spend on each question.*

Advice

- Read each question carefully before you start to answer it.
- Try to answer every question.
- Check your answers if you have time at the end.

Turn over ►

P72067A

©2023 Pearson Education Ltd.

J:1/1/1/1/1/1/



Pearson

1.

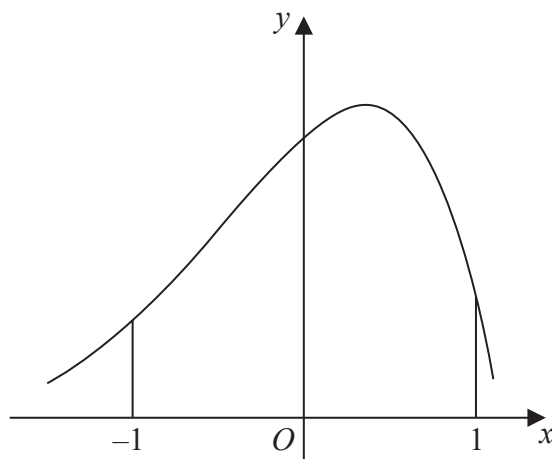

Figure 1

Figure 1 shows a sketch of part of the curve with equation $y = f(x)$

The table below shows some corresponding values of x and y for this curve.

The values of y are given to 3 decimal places.

x	-1	-0.5	0	0.5	1
y	2.287	4.470	6.719	7.291	2.834

Using the trapezium rule with all the values of y in the given table,

(a) obtain an estimate for

$$\int_{-1}^1 f(x) \, dx$$

giving your answer to 2 decimal places.

(3)

(b) Use your answer to part (a) to estimate

(i) $\int_{-1}^1 (f(x) - 2) \, dx$

(ii) $\int_1^3 f(x-2) \, dx$

(3)



2.

In this question you must show all stages of your working.

Solutions based entirely on calculator technology are not acceptable.

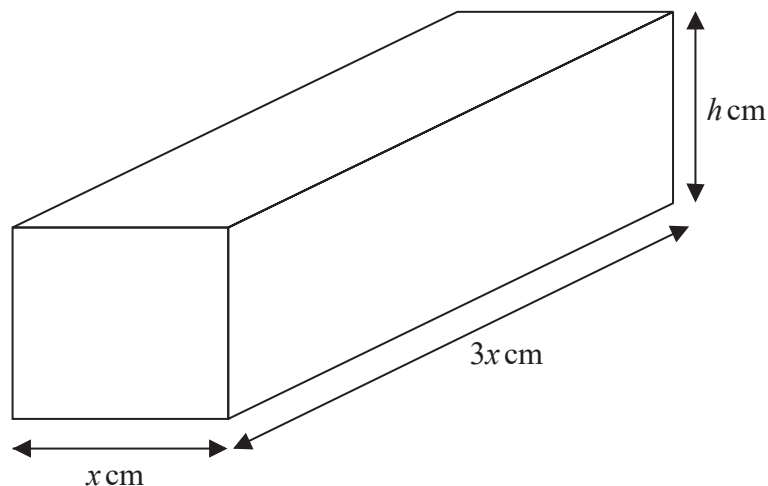

Figure 2

A brick is in the shape of a cuboid with width x cm, length $3x$ cm and height h cm, as shown in Figure 2.

The volume of the brick is 972 cm^3

(a) Show that the surface area of the brick, $S \text{ cm}^2$, is given by

$$S = 6x^2 + \frac{2592}{x}$$

(3)

(b) Find $\frac{dS}{dx}$

(1)

(c) Hence find the value of x for which S is stationary.

(2)

(d) Find $\frac{d^2S}{dx^2}$ and hence show that the value of x found in part (c) gives the minimum value of S .

(2)

(e) Hence find the minimum surface area of the brick.

(1)



Question 3 continued

DO NOT WRITE IN THIS AREA

DO NOT WRITE IN THIS AREA

DO NOT WRITE IN THIS AREA

Ruled writing area with horizontal lines.

(Total for Question 3 is 7 marks)



P 7 2 0 6 7 A 0 9 3 2

4. (i) Using the laws of logarithms, solve

$$\log_3(4x) + 2 = \log_3(5x + 7) \quad (3)$$

(ii) Given that

$$\sum_{r=1}^2 \log_a(y^r) = \sum_{r=1}^2 (\log_a y)^r \quad y > 1, a > 1, y \neq a$$

find y in terms of a , giving your answer in simplest form. (3)



Question 4 continued

DO NOT WRITE IN THIS AREA

DO NOT WRITE IN THIS AREA

DO NOT WRITE IN THIS AREA

Lined writing area for the answer to Question 4.

(Total for Question 4 is 6 marks)



P 7 2 0 6 7 A 0 1 1 3 2

5.

$$f(x) = x^3 + (p + 3)x^2 - x + q$$

where p and q are constants and $p > 0$

Given that $(x - 3)$ is a factor of $f(x)$

(a) show that

$$9p + q = -51 \quad (2)$$

Given also that when $f(x)$ is divided by $(x + p)$ the remainder is 9

(b) show that

$$3p^2 + p + q - 9 = 0 \quad (2)$$

(c) Hence find the value of p and the value of q . (3)

(d) Hence find a quadratic expression $g(x)$ such that

$$f(x) = (x - 3)g(x) \quad (2)$$



Question 5 continued

DO NOT WRITE IN THIS AREA

DO NOT WRITE IN THIS AREA

DO NOT WRITE IN THIS AREA

Lined writing area for the answer to Question 5.



Question 5 continued

DO NOT WRITE IN THIS AREA

DO NOT WRITE IN THIS AREA

DO NOT WRITE IN THIS AREA

Lined writing area for the answer.



Question 5 continued

DO NOT WRITE IN THIS AREA

DO NOT WRITE IN THIS AREA

DO NOT WRITE IN THIS AREA

Lined writing area for the answer to Question 5.

(Total for Question 5 is 9 marks)



P 7 2 0 6 7 A 0 1 5 3 2

Question 6 continued

DO NOT WRITE IN THIS AREA

DO NOT WRITE IN THIS AREA

DO NOT WRITE IN THIS AREA

Lined writing area for the answer to Question 6.



Question 6 continued

Lined writing area for the question. The area is bounded by horizontal lines and contains the text 'Question 6 continued' at the top left.

DO NOT WRITE IN THIS AREA

DO NOT WRITE IN THIS AREA

DO NOT WRITE IN THIS AREA

(Total for Question 6 is 10 marks)



7. A geometric sequence has first term a and common ratio r , where $r > 0$

Given that

- the 3rd term is 20
- the 5th term is 12.8

(a) show that $r = 0.8$

(1)

(b) Hence find the value of a .

(2)

Given that the sum of the first n terms of this sequence is greater than 156

(c) find the smallest possible value of n .

(Solutions based entirely on graphical or numerical methods are not acceptable.)

(4)



8.

In this question you must show all stages of your working.

Solutions based entirely on calculator technology are not acceptable.

- (i) Solve, for $-\frac{\pi}{2} < x < \pi$, the equation

$$5 \sin(3x + 0.1) + 2 = 0$$

giving your answers, **in radians**, to 2 decimal places.

(4)

- (ii) Solve, for $0 < \theta < 360^\circ$, the equation

$$2 \tan \theta \sin \theta = 5 + \cos \theta$$

giving your answers, **in degrees**, to one decimal place.

(5)



Question 8 continued

DO NOT WRITE IN THIS AREA

DO NOT WRITE IN THIS AREA

DO NOT WRITE IN THIS AREA

Lined writing area for the answer to Question 8.



P 7 2 0 6 7 A 0 2 3 3 2

9.

In this question you must show all stages of your working.

Solutions based entirely on calculator technology are not acceptable.

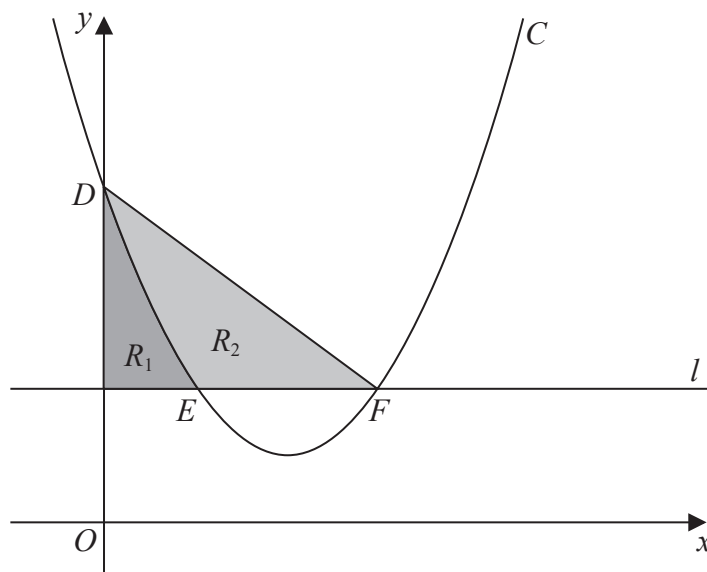

Figure 3

Figure 3 shows

- the curve C with equation $y = x^2 - 4x + 5$
- the line l with equation $y = 2$

The curve C intersects the y -axis at the point D .

(a) Write down the coordinates of D .

(1)

The curve C intersects the line l at the points E and F , as shown in Figure 3.

(b) Find the x coordinate of E and the x coordinate of F .

(2)

Shown shaded in Figure 3 is

- the region R_1 which is bounded by C , l and the y -axis
- the region R_2 which is bounded by C and the line segments EF and DF

Given that $\frac{\text{area of } R_1}{\text{area of } R_2} = k$, where k is a constant,

(c) use algebraic integration to find the exact value of k , giving your answer as a simplified fraction.

(5)



Question 9 continued

DO NOT WRITE IN THIS AREA

DO NOT WRITE IN THIS AREA

DO NOT WRITE IN THIS AREA

Lined writing area consisting of multiple horizontal lines for text entry.



P 7 2 0 6 7 A 0 2 7 3 2

Question 9 continued

DO NOT WRITE IN THIS AREA

DO NOT WRITE IN THIS AREA

DO NOT WRITE IN THIS AREA



Question 9 continued

DO NOT WRITE IN THIS AREA

DO NOT WRITE IN THIS AREA

DO NOT WRITE IN THIS AREA

Lined writing area for the answer to Question 9.

(Total for Question 9 is 8 marks)



P 7 2 0 6 7 A 0 2 9 3 2

10. A student was asked to prove by exhaustion that

if n is an integer then $2n^2 + n + 1$ is **not** divisible by 3

The start of the student's proof is shown in the box below.

Consider the case when $n = 3k$

$$2n^2 + n + 1 = 18k^2 + 3k + 1 = 3(6k^2 + k) + 1$$

which is not divisible by 3

Complete this proof.

(4)



Question 10 continued

DO NOT WRITE IN THIS AREA

DO NOT WRITE IN THIS AREA

DO NOT WRITE IN THIS AREA

Lined writing area with horizontal lines.



P 7 2 0 6 7 A 0 3 1 3 2

