

# Pearson Edexcel Level 1 / Level 2 GCSE (9-1) in Mathematics (1MA1)

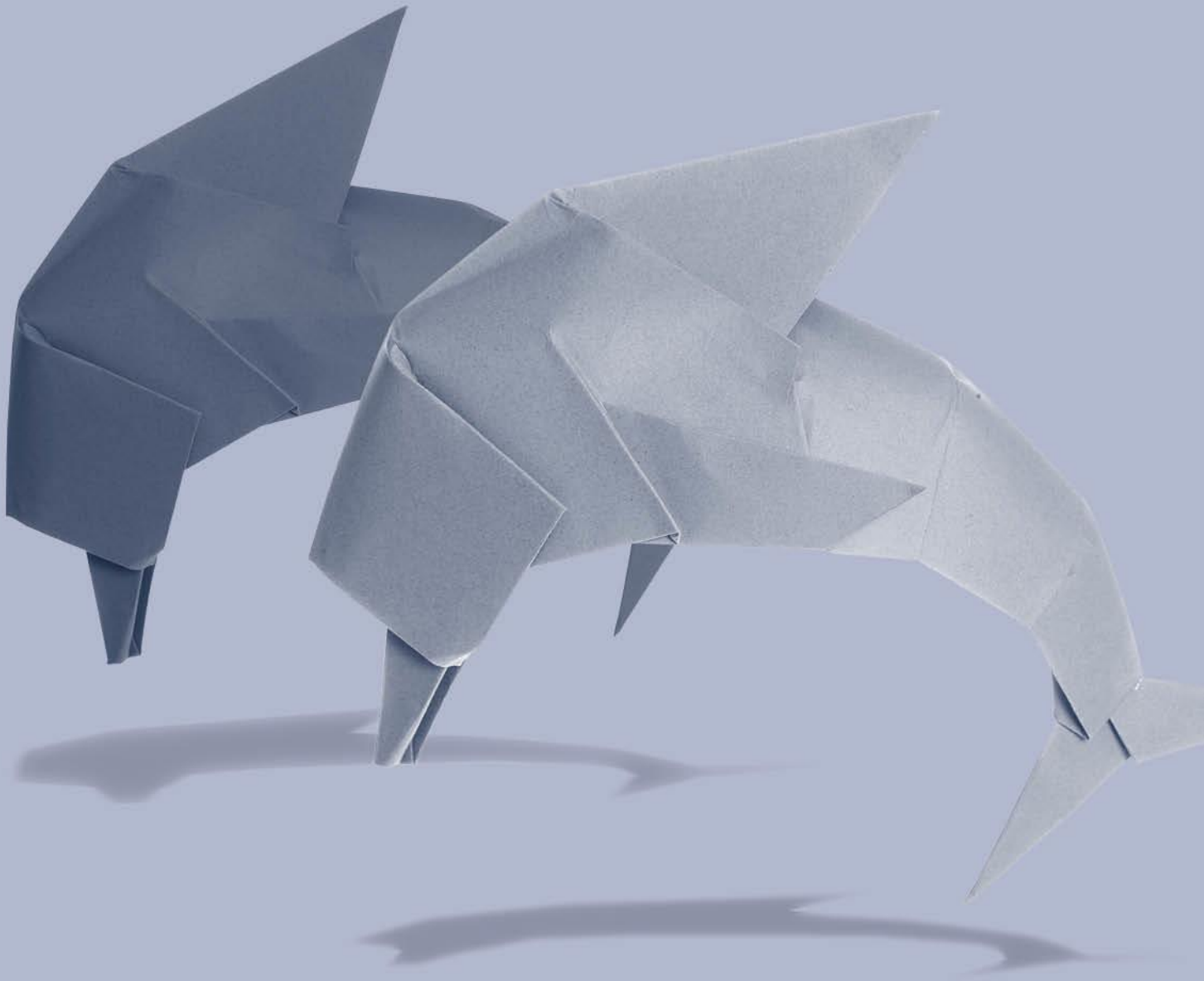

**MOCK (AUTUMN 2016) MODEL ANSWERS**

---

First certification 2017

---

# Contents

---

<b>Contents</b> .....	<b>2</b>
<b>About this booklet</b> .....	<b>3</b>
<b>Paper 1F</b> .....	<b>4</b>
<b>1F/1H Common Questions</b> .....	<b>8</b>
<b>Paper 1H</b> .....	<b>12</b>
<b>Paper 2F</b> .....	<b>19</b>
<b>2F/2H Common Questions</b> .....	<b>26</b>
<b>Paper 2H</b> .....	<b>28</b>
<b>Paper 3F</b> .....	<b>35</b>
<b>Paper 3F/3H Common Questions</b> .....	<b>39</b>
<b>Paper 3H</b> .....	<b>45</b>

## About this booklet

---

This booklet has been produced to support mathematics teachers delivering the new GCSE (9–1) in Mathematics specification (first assessment summer 2017).

This booklet provides model answers for problem-solving questions, exemplifying some of the problem-solving strategies.

The questions in this booklet have been drawn from the Autumn 2016 Mock Papers. The questions selected are those where most of the marks assess AO3 Solve problems within mathematics and in other contexts.

In each pair of Foundation and Higher tier papers, there are common questions that appear at each tier; in this booklet we have provided the model answers for common questions at Higher tier only, but the following selected questions also appear on the Foundation tier papers:

1F Q19 = 1H Q3

1F Q20 = 1H Q4

1F Q21 = 1H Q5

2F Q26 = 2H Q4

3F Q18 = 3H Q1

3F Q20 = 3H Q3

3F Q23 = 3H Q6

3F Q24 = 3H Q7

## Paper 1F

---

6

pen	32p
pencil	8p
ruler	17p

Rosie has £15 to spend on pens and pencils.

She has to buy the same number of pens as pencils.

What is the greatest number of pens she can buy?

$$\text{Cost of 1 pen + 1 pencil} = 32\text{p} + 8\text{p} = 40\text{p} = \text{£}0.40$$

Finding the amount of sets she can buy for £15

$$15 \div 0.4 = 150 \div 4 = 37.5$$

Rosie does not have enough money to buy the 38<sup>th</sup> pen and pencil so the answer is rounded down.

### Alternative Method

$$5 = \text{£}2$$

$$10 = \text{£}4$$

$$30 = \text{£}12$$

$$35 = \text{£}14$$

$$36 = \text{£}14.40$$

$$37 = \text{£}14.40 - \text{not enough money for 38.}$$

.....  
**(Total for Question 6 is 3 marks)**

- 9 The formulae below can be used to work out the cost, £ $C$ , of a taxi journey of  $x$  miles with three different taxi companies.

<b>Reliable Taxis</b> $C = 1.5x$	<b>Speedy Taxis</b> $C = 1.1x + 11.5$	<b>City Taxis</b> $C = 1.25x + 8$
-------------------------------------	--	--------------------------------------

Which is the cheapest company to use for a taxi journey of 30 miles?  
 You must show how you get your answer.

Using a table

Company	Formula, using $x = 30$	Total cost
Reliable Taxis	$C = 1.5 \times 30$	£45.00
Speedy Taxis	$C = (1.1 \times 30) + 11.5$	£44.50
City Taxis	$C = (1.25 \times 30) + 8$	£45.50

} Compare

Speedy Taxis is the cheapest company to use at £44.50 for the total cost of the journey.

**(Total for Question 9 is 3 marks)**

---

13 This shape is made from two rectangles.

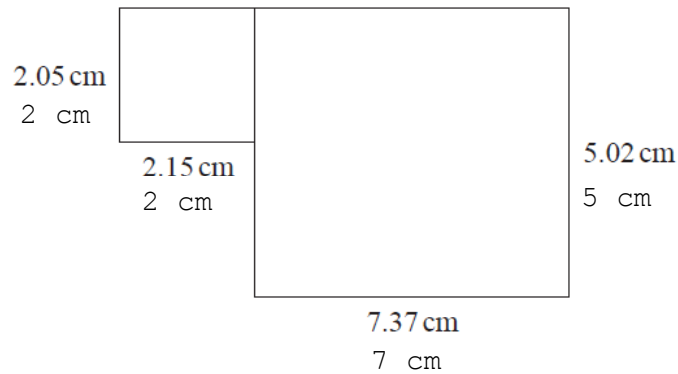

(a) Work out an estimate for the total area of the shape.

Using simpler numbers,  
estimates for all given sides written on the diagram

Using a flow diagram,

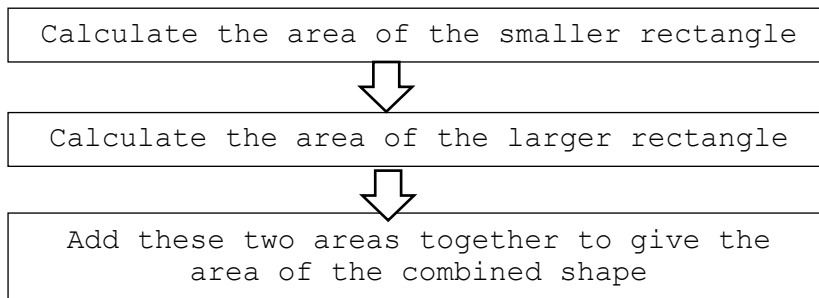

Area of smaller rectangle =  $2 \times 2 = 4 \text{ cm}^2$

Area of larger rectangle =  $7 \times 5 = 35 \text{ cm}^2$

Total area of combined shape =  $4 + 35 = 39 \text{ cm}^2$

.....  $\text{cm}^2$

**(3)**

(b) Is your answer to (a) an overestimate or an underestimate?

Give a reason for your answer.

The answer to (a) is an underestimate because all numbers have been rounded down. 2cm is less than 2.05cm, 2cm is less than 2.15cm, 7cm is less than 7.37cm and 5cm is less than 5.02cm, therefore the answer of  $39 \text{ cm}^2$  will be less than the actual answer.

.....

.....

**(1)**

**(Total for Question 13 is 4 marks)**

15  $ABCD$  is a kite with  $AD = AB$

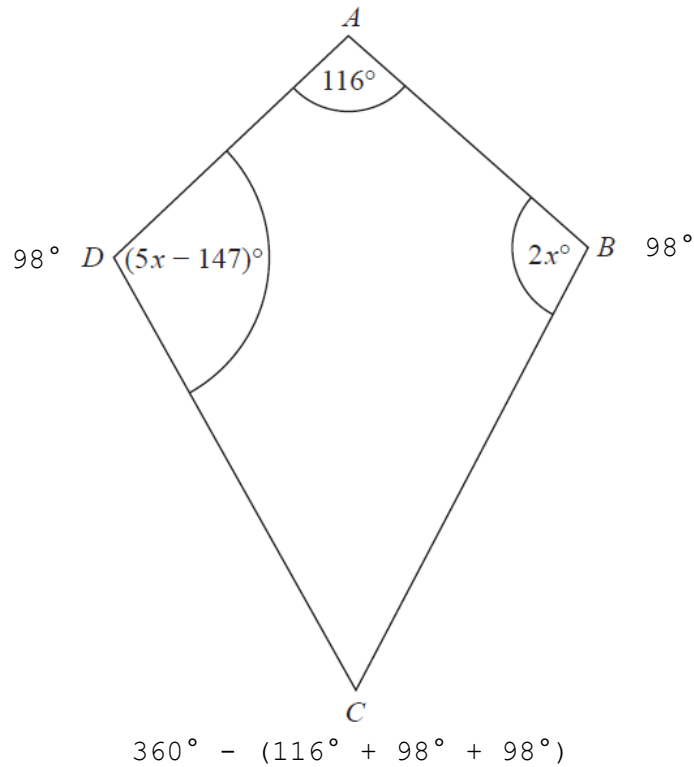

Find the size of the smallest angle of the kite.

Using  $x$  for the unknown and adding to the diagram,

Angles  $B$  and  $D$  are the same, so

$$5x - 147 = 2x$$

Rearranging gives  $3x = 147$

Solving for  $x$   $x = 147 \div 3$

Angle  $B = 2x$

Substituting  $x = 49$  into the equation,

Angle  $B = 2 \times 49 = 98^\circ$  which is also equal to angle  $D$

All angles in a quadrilateral sum to  $360^\circ$ , so missing angle  $C$  is equal to

$$360 - (116 + 98 + 98) = 48^\circ$$

.....<sup>o</sup>

**(Total for Question 15 is 4 marks)**

## 1F/1H Common Questions

- 3  $ABCDE$  is a pentagon.

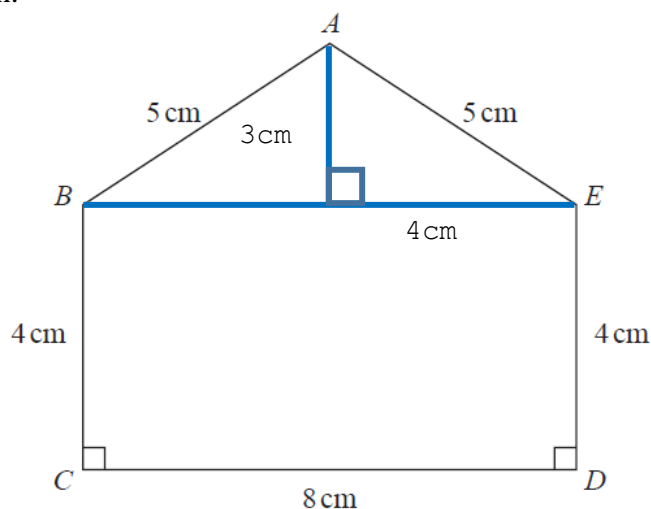

Work out the area of  $ABCDE$ .

Using flow diagrams and adding to the diagram,

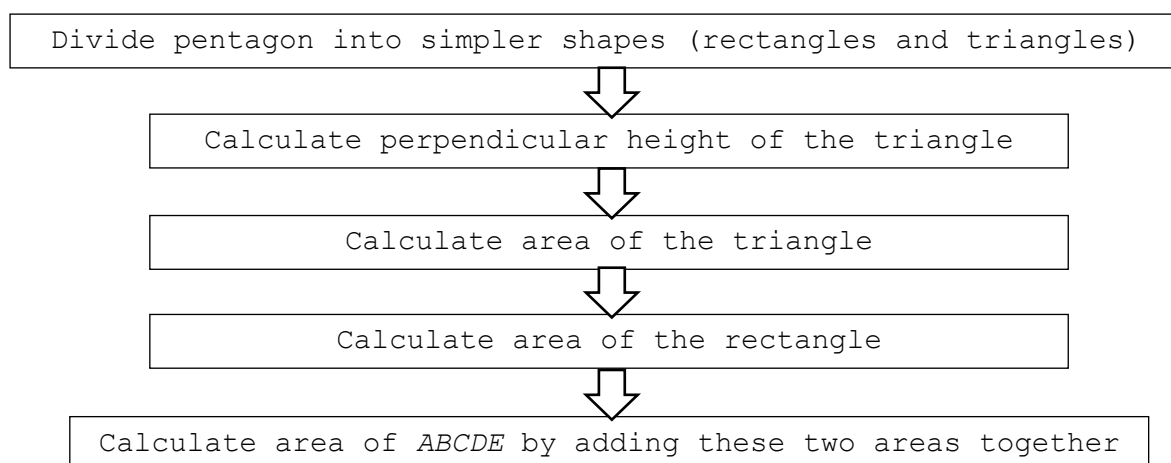

Using Pythagoras' theorem to find height of triangle,

$$5^2 = 4^2 + c^2$$
$$5^2 - 4^2 = c^2$$
$$c = \sqrt{5^2 - 4^2} = 3$$

$$\begin{aligned} \text{Area of triangle} &= (\text{base} \times \text{height}) \div 2 \\ &= (8 \times 3) = 12 \text{ cm}^2 \end{aligned}$$

$$\begin{aligned} \text{Area of rectangle} &= \text{base} \times \text{height} \\ &= 4 \times 8 = 32 \text{ cm}^2 \end{aligned}$$

$$\text{Area of } ABCDE = 12 \text{ cm}^2 + 32 \text{ cm}^2 = 44 \text{ cm}^2$$

**(Total for Question 3 is 5 marks)**

4 On Monday, Tarek travelled by train from Manchester to London.

Tarek's train left Manchester at 08 35

It got to London at 11 05

The train travelled at an average speed of 110 miles per hour.

On Wednesday, Gill travelled by train from Manchester to London.

Gill's train also left at 08 35 but was diverted.

The train had to travel an extra 37 miles.

The train got to London at 11 35

Work out the difference between the average speed of Tarek's train and the average speed of Gill's train.

In order to calculate Gill's average speed, we need to know the distance from Manchester to London.

Tarek's journey time from 08 35 to 11 05 is 2.5 hours.

Using a diagram,

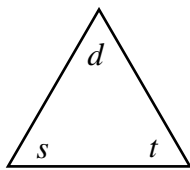

$$\begin{aligned} \text{distance} &= \text{speed} \times \text{time} \\ &= 110 \times 2.5 = 275 \text{ miles} \end{aligned}$$

Gill's journey time from 08 35 to 11 35 is 3 hours.

$$\begin{aligned} \text{Gill's average speed} &= \text{distance} \div \text{time} \\ &= (275 + 37) \div 3 = 104 \text{ miles per hour} \end{aligned}$$

Difference between the average speed of Tarek's train and the average speed of Gill's train is

$$110 - 104 = 6 \text{ miles per hour}$$

..... miles per hour

**(Total for Question 4 is 4 marks)**

- 5 The diagram shows a rectangular wall.

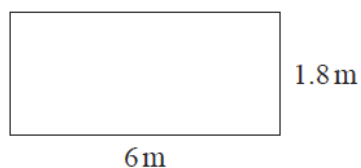

Frank is going to cover the wall with rectangular tiles.  
Each tile is 60 cm by 30 cm.

$\frac{3}{5}$  of the tiles will be white.

Some of the tiles will be green.  
The rest of the tiles will be blue.

The ratio of the number of green tiles to the number of blue tiles will be 1 : 3

- (a) Assuming there are no gaps between the tiles, how many tiles of each colour will Frank need?

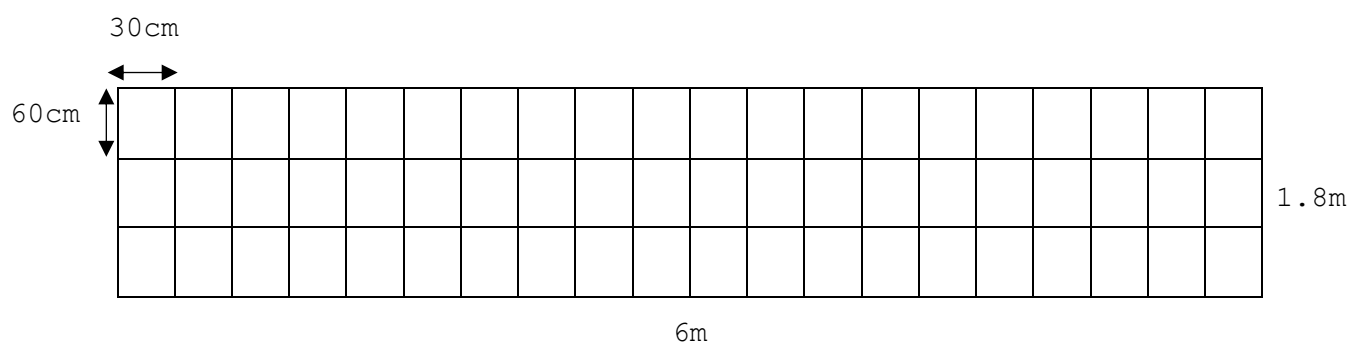

Arranged to fit the wall with 3 rows of 20, there are 60 tiles in total.

Using bar models,

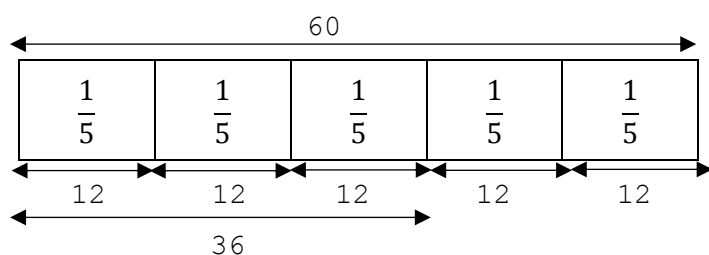

so 36 tiles are white.

**OR**

White tiles =  $\frac{3}{5}$  of 60 =  $60 \div 5 \times 3 = 36$

The number of tiles remaining are  $60 - 36 = 24$

**Pearson Edexcel Level 1/Level 2 GCSE (9-1) in Mathematics (1MA1),  
Paper 1F/1H Common Questions**

The remaining 24 tiles will be green and blue in a ratio of 1:3

24 tiles into 4 parts =  $24 \div 4 = 6$  tiles per part

Using bar models,

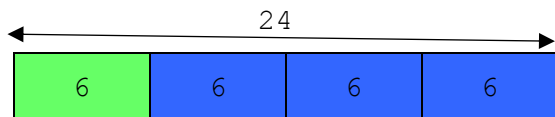

**OR**

1 part = 6 tiles

Green tiles =  $6 \times 1 = 6$

Blue tiles =  $6 \times 3 = 18$

There are 6 green tiles and 18 blue tiles.

White tiles = 36

Green tiles = 6

Blue tiles = 18

white tiles .....

green tiles .....

blue tiles .....

**(5)**

Frank is told that he should leave gaps between the tiles.

(b) If Frank leaves gaps between the tiles, how could this affect the number of tiles he needs?

Frank may need fewer tiles.

**(1)**

**(Total for Question 5 is 6 marks)**

## Paper 1H

9 A company orders a number of bottles from a factory.

The 8 machines in the factory could make all the bottles in 5 days.

All the machines work at the same rate.

For 2 days, only 4 machines are used to make the bottles.

From the 3rd day, all 8 machines are used to make the bottles.

Work out the total number of days taken to make all the bottles.

Using bar models,

Machine	1	2	3	4	5	6	7	8	
Days	5	5	5	5	5	5	5	5	= 40 machine days

40 machine days are required to make all the bottles.

4 machines are used for 2 days

Machine	1	2	3	4	
Days	2	2	2	2	= 8 machine days

There are  $40 - 8 = 32$  more machine days needed to complete the job.

8 machines are used for the remainder of days until completion

Machine	1	2	3	4	5	6	7	8	
Days	?	?	?	?	?	?	?	?	= 32 machine days

$32 \div 8 = 4$  days

Total time taken to make all the bottles is  $2 + 4 = 6$  days

**OR**

$$\text{Machine days needed} = 8 \times 5 = 40$$

$$4 \text{ machines working for 2 days} = 4 \times 2 = 8 \text{ machine days}$$

There are  $40 - 8 = 32$  more machine days needed to complete the job.

Using  $x$  for the unknown,

$$8 \text{ machines working for } x \text{ days} = 8x = 32 \text{ machine days}$$

$$x = 32 \div 8 = 4 \text{ days}$$

Total time taken to make all the bottles is  $2 + 4 = 6$  days

**OR**

$$4 \text{ machines for 2 days} = 8 \text{ machines for 1 day}$$

Therefore, only one extra day required giving a total of 6 days.

**OR**

$$8 \text{ machines for 5 days} = 100\%$$

$$8 \text{ machines for 1 day} = 20\%$$

$$4 \text{ machines for 1 day} = 10\%$$

$$4 \text{ machines for 2 days} = 20\%$$

80% remaining which is 4 days with 8 machines. Giving a total of 6 days.

..... days

**(Total for Question 9 is 3 marks)**

15 Here is a sketch of a vertical cross section through the centre of a bowl.

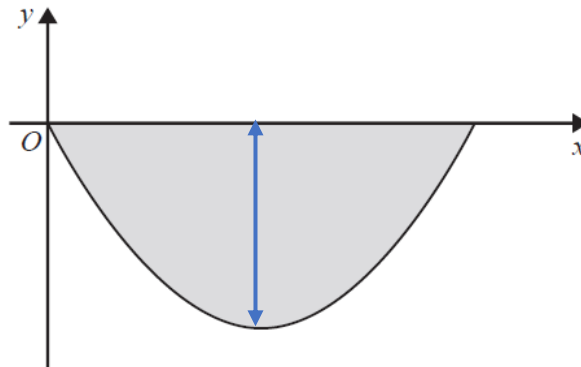

The cross section is the shaded region between the curve and the  $x$ -axis.

The curve has equation  $y = \frac{x^2}{10} - 3x$  where  $x$  and  $y$  are both measured in centimetres.

Find the depth of the bowl.

Using graphs,

The curve hits the  $x$ -axis where  $y = 0$ , so

$$\frac{x^2}{10} - 3x = 0$$

$$x\left(\frac{1}{10}x - 3\right) = 0, \text{ so } x = 0 \text{ and}$$

$$\frac{1}{10}x - 3 = 0$$

$$\frac{1}{10}x = 3, \text{ so } x = 30$$

The depth of the bowl is therefore the  $y$  value at  $x = 30 \div 2 = 15$

Substituting  $x$  into the equation of the curve,

$$y = \frac{15^2}{10} - (3 \times 15) = 22.5 \times 45 = -22.5$$

The depth of the bowl is 22.5cm

..... cm

**(Total for Question 15 is 4 marks)**

- 18 The diagram shows the first 10 sides of a spiral pattern.  
It also gives the lengths, in cm, of the first 5 sides.

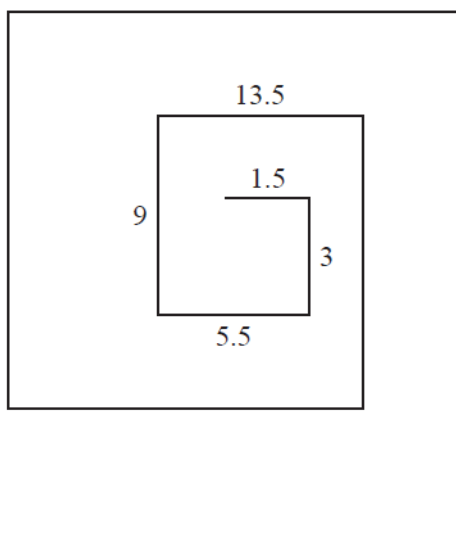

The lengths, in cm, of the sides of the spiral form a sequence.

Find an expression in terms of  $n$  for the length, in cm, of the  $n$ th side.

Looking for patterns,

1.5	3	5.5	9	13.5	
	1.5	2.5	3.5	4.5	First differences
		1	1	1	Second differences

Common second differences, therefore sides of the spiral form a quadratic sequence. If the second difference is 2, we start with  $n^2$ , but the second difference is 1 so we start with  $\frac{1}{2}n^2$

Using a table,

$n$	Length	$n^2$	$\frac{1}{2}n^2$	$\frac{1}{2}n^2 + 1$
1	1.5	1	0.5	1.5
2	3	4	2	3
3	5.5	9	4.5	5.5
4	9	16	8	9
5	13.5	25	12.5	13.5

An expression for the length of the  $n$ th side is therefore  $\frac{1}{2}n^2 + 1$

**(Total for Question 18 is 3 marks)**

- 23 The histogram shows information about the ages of the members of a football supporters club.

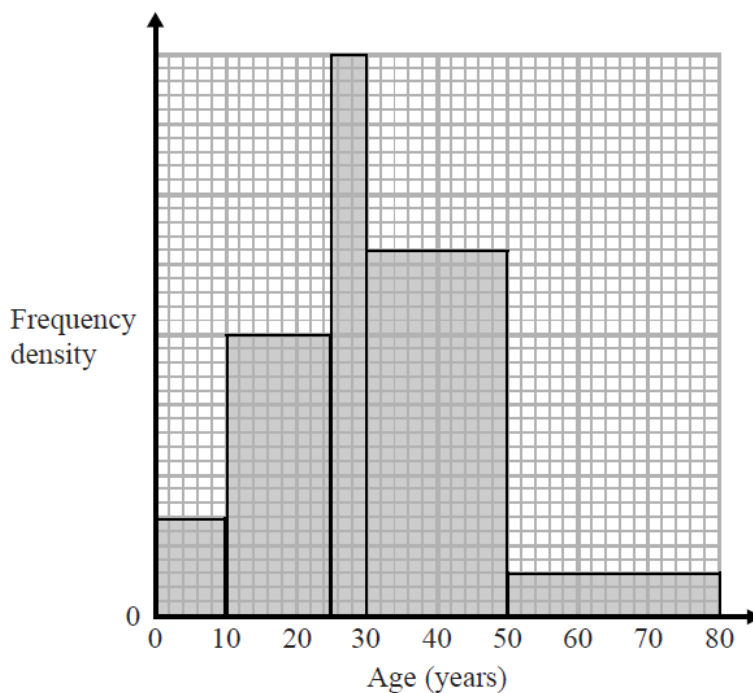

There are 20 members aged between 25 and 30

One member of the club is chosen at random.

What is the probability that this member is more than 30 years old?

Using flow diagrams,

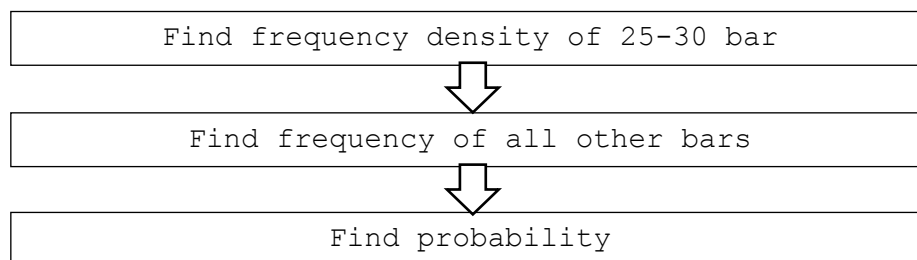

25-30 years

$$\begin{aligned} \text{Frequency density} &= \text{frequency} \div \text{class width} \\ &= 20 \div 5 = 4 \end{aligned}$$

Marking the scale on the y-axis on the graph, we can now calculate frequencies of the other bars.

Using a table,

Age (years)	Frequency density × class width	Frequency
0-10	$0.7 \times 10$	7
10-25	$2 \times 15$	30
25-30		20
30-50	$2.6 \times 20$	52
50-80	$0.3 \times 30$	9
Total		118

Members over 30

$$52 + 9 = 61$$

Probability of member being over 30

= Members over 30 ÷ Total members

$$= \frac{61}{118}$$

.....  
**(Total for Question 23 is 3 marks)**

---

- 24 There are  
 6 black counters and 4 white counters in bag **A**  
 7 black counters and 3 white counters in bag **B**  
 5 black counters and 5 white counters in bag **C**

Bernie takes at random a counter from bag **A** and puts the counter in bag **B**.  
 He then takes at random a counter from bag **B** and puts the counter in bag **C**.

Find the probability that there are now more black counters than white counters in bag **C**.

There are more black counters than white counters in bag **C** if the counter Bernie takes from bag **B** is black.

There are two scenarios:

A black counter is taken from bag **A** and then  
 a black counter is taken from bag **B**

**OR**

A white counter is taken from bag **A** and then  
 a black counter is taken from bag **B**.

Using bar models,



If a black counter is chosen, bag B will have 8 black and 3 white:

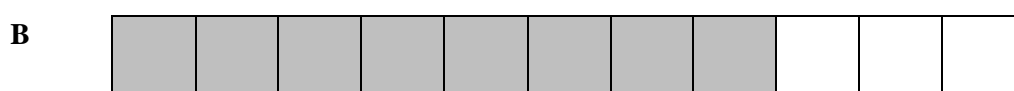

If a white counter is chosen, bag B will have 7 black and 4 white:

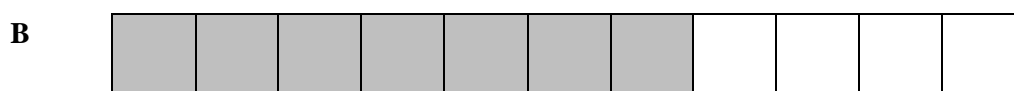

The probability of the first scenario is therefore  $\frac{6}{10} \times \frac{8}{11}$  and the probability of the second scenario is  $\frac{4}{10} \times \frac{7}{11}$

The probability of either of these scenarios is therefore

$$\left(\frac{6}{10} \times \frac{8}{11}\right) + \left(\frac{4}{10} \times \frac{7}{11}\right) = \frac{48}{110} + \frac{28}{110} = \frac{76}{110}$$

**(Total for Question 24 is 3 marks)**

## Paper 2F

7 Here is a regular hexagon.

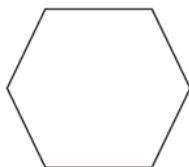

There are six identical hexagons.

Three of the hexagons are joined to make shape **A**.

The other three hexagons are joined to make shape **B**.

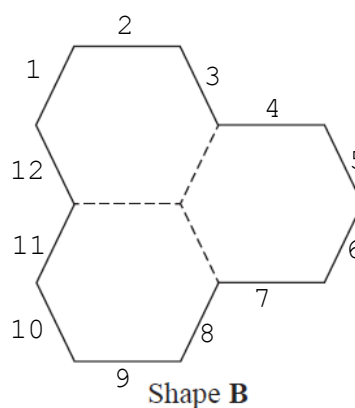
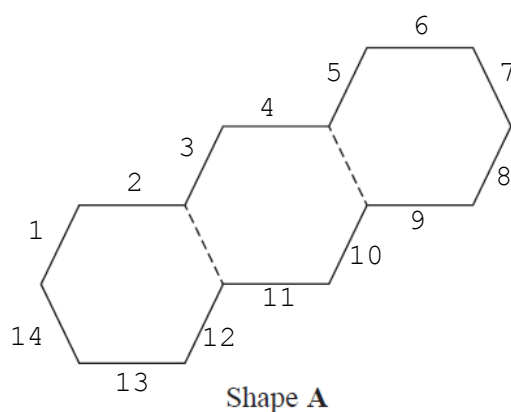

Which shape has the greater perimeter, shape **A** or shape **B**?

You must show how you get your answer.

Using diagrams,

Counting the sides (labelled on diagram), Shape A has 14 sides and Shape B has 12 sides.

Shape A therefore has the greatest perimeter.

**(Total for Question 7 is 2 marks)**

13 Drinks and snacks can be bought in a cinema.

Drinks		Snacks	
coffee	£1.50	popcorn	£1.75
cola	£1.25	nachos	£1.15
orange	95p	ice cream	£1.60
		chocolate	85p
<b>Special Offer</b>			
Buy one drink and two different snacks for £3.99			

Laura is going to buy one drink and two different snacks.

Work out the most money that Laura can save by using the Special Offer.

Laura saves the most money by purchasing the most expensive items, so we add these items together to get the total price without using the Special Offer.

$$£1.50 + £1.75 + £1.60 = £4.85$$

Using bar models to find the money saved using the Special Offer,

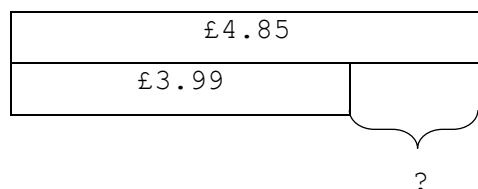

$$\text{Amount saved} = £4.85 - £3.99 = £0.86 = 86\text{p}$$

.....  
**(Total for Question 13 is 3 marks)**

- 15 Jake is going to make a path from small paving stones and large paving stones. The diagram shows Jake's design for the path. The rest of the path is made using the same pattern of paving stones.

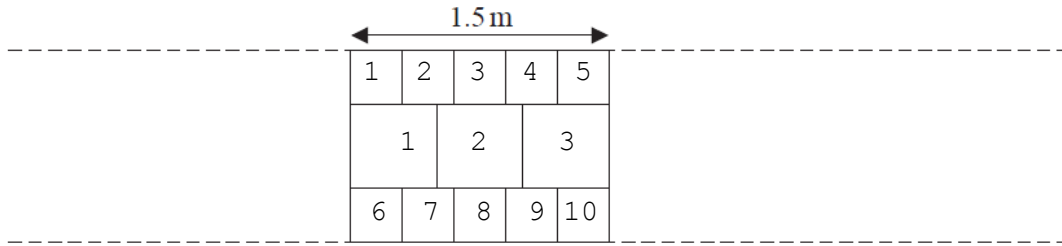

A small paving stone costs £2.30

A large paving stone costs £3.65

Jake needs to buy enough paving stones to make a path that is 6 metres long.

- (a) How much will Jake have to pay for the paving stones he needs?

Using the diagram to count how many of each type of tile, there are 10 small paving stones and 3 large paving stones in each 1.5m section.

Using bar models to find the total cost of each 1.5m section,

£2.30	£2.30	£2.30	£2.30	£2.30	£2.30	£2.30	£2.30	£2.30	£2.30
£2.30	£4.60	£6.90	£9.20	£11.50	£13.80	£16.10	£18.40	£20.70	£23.00

£3.65	£3.65	£3.65
£3.65	£7.30	£10.95

Total cost of each 1.5m section = £23.00 + £10.95 = £33.95

OR

$$\begin{aligned} \text{Cost of each 1.5m section} &= (10 \times £2.30) + (3 \times £3.65) \\ &= £23.00 + £10.95 = £33.95 \end{aligned}$$

There are  $6 \div 1.5 = 4$  of these sections

Therefore the total cost is  $4 \times 33.95 = £135.80$

£.....

(4)

Harry designs a different path that is also 6 metres long using the large paving stones.

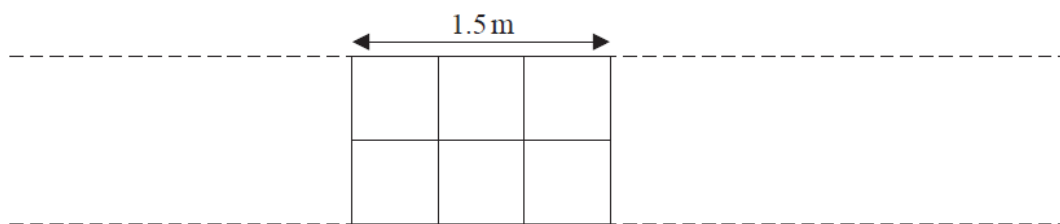

Harry says that the cost of his path will be less than half of the cost of the path that Jake designed.

(b) Is Harry correct?

You must show how you get your answer.

Harry's pattern uses 6 large paving stones that cost £3.65 each,  
Therefore the cost of each 1.5 section is

$$6 \times 3.65 = \text{£}21.90$$

From part (a), we know that there are 4 of these 1.5m sections, so  
the total cost is

$$21.90 \times 4 = \text{£}87.60$$

Half the cost of Jake's path is

$$135.80 \div 2 = \text{£}67.90$$

Comparing these costs,

$$\text{£}87.60 > \text{£}67.90$$

Therefore Harry's path costs more than half the cost of Jake's path  
and Harry is wrong.

(2)

**(Total for Question 15 is 6 marks)**

---

- 16 In September Sharon paid £565 for some books.  
She sold all the books for a total of £780

In October Sharon bought and sold some more books.  
The total profit she made in October was 13% greater than the total profit she made in September.

In November Sharon wants to pay a bill of £30  
Sharon thinks that the 13% extra profit she made in October will be enough to pay this bill.

Is Sharon correct?  
You must show all your working.

Using flow diagrams,

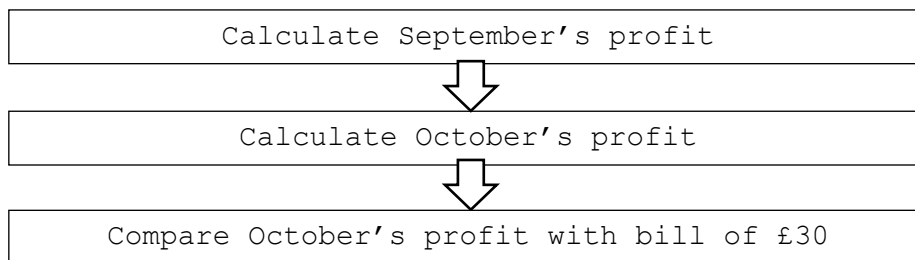

Using bar models,

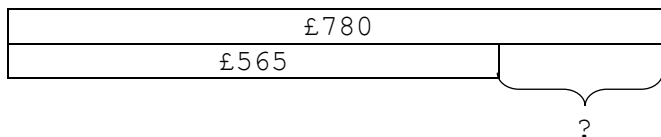

$$\begin{aligned} \text{September profit} &= \text{Price books sold for} - \text{price books bought for} \\ &= £780 - £565 = £215 \end{aligned}$$

Finding 13% of £215 using bar models,

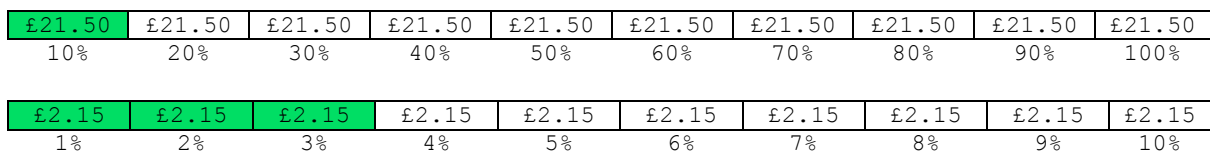

The extra profit made in October is  
13% of £215 = £21.50 + £2.15 + £2.15 + £2.15 = £27.95

**OR**

$$13\% \text{ of } £215 = 215 \div 100 \times 13 = £27.95$$

**OR**

$$13\% \text{ of } £215 = 0.13 \times 215 = £27.95$$

£27.95 < £30, so the extra profit is not enough to pay the bill.

**(Total for Question 16 is 3 marks)**

- 20 The diagram shows a shape made by overlapping two identical squares.

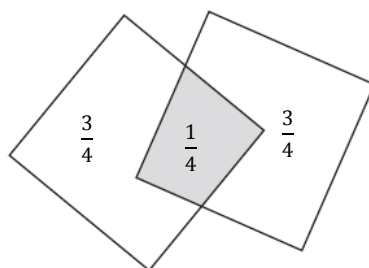

The area of the shaded region is 25% of the area of each square.

Work out what fraction of the area of the whole shape is shaded.

Labelling the diagram,

$$\text{Whole shape} = \frac{1}{4} + \frac{3}{4} + \frac{3}{4} = \frac{7}{4}$$

The fraction of the area of the whole shape that is shaded is,

Using  $x$  for the unknown,

$$x \text{ of } \frac{7}{4} = \frac{1}{4}$$

$$x = \frac{1}{4} \div \frac{7}{4} = \frac{1}{7}$$

**OR**

$$\text{Whole shape} = 25\% + 75\% + 75\% = 175\%$$

$$\text{Fraction Shaded} = \frac{25}{175} = \frac{1}{7}$$

.....  
**(Total for Question 20 is 3 marks)**

21 There are 240 students in Year 7 at a school.

The pie chart shows the proportion of boys and the proportion of girls in Year 7.

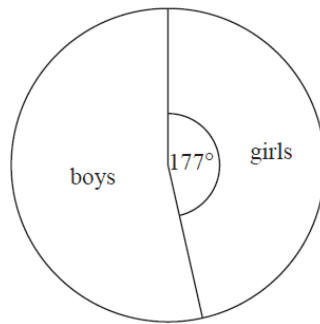

There are 8 more girls in Year 8 than in Year 7.

There are 32 fewer boys in Year 8 than in Year 7.

Andy draws a pie chart to show the proportion of boys and the proportion of girls in Year 8

Work out the angle of the sector in Andy's pie chart that represents girls.

Using flow diagrams,

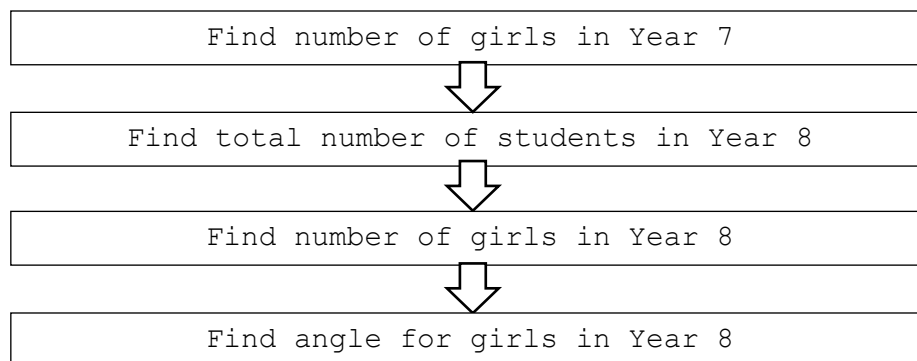

$$\text{Number of girls in Year 7} = \frac{177}{360} \times 240 = 118$$

$$\text{Year 8 girls} = 118 + 8 = 126$$

$$\text{Year 8 boys} = (240 - 118) - 32 = 90$$

$$\begin{aligned} \text{Total number of students in Year 8} &= \text{Year 8 girls} + \text{Year 8 boys} \\ &= 126 + 90 = 216 \end{aligned}$$

$$\begin{aligned} \text{Angle for girls in Year 8} &= \frac{\text{Girls in Year 8}}{\text{Total students in Year 8}} \times 360^\circ \\ &= \frac{126}{216} \times 360^\circ = 210^\circ \end{aligned}$$

**(Total for Question 21 is 4 marks)**

## 2F/2H Common Questions

- 4 The diagram shows a shape  $ABCDEF$ .

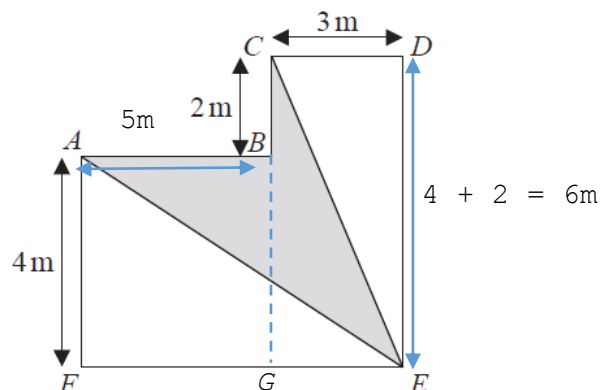

All the corners of the shape are right angles.  
The perimeter of the shape is 28 m.

Work out the area of  $ABCE$  shown shaded on the diagram.

Using the diagram and a flow diagram,

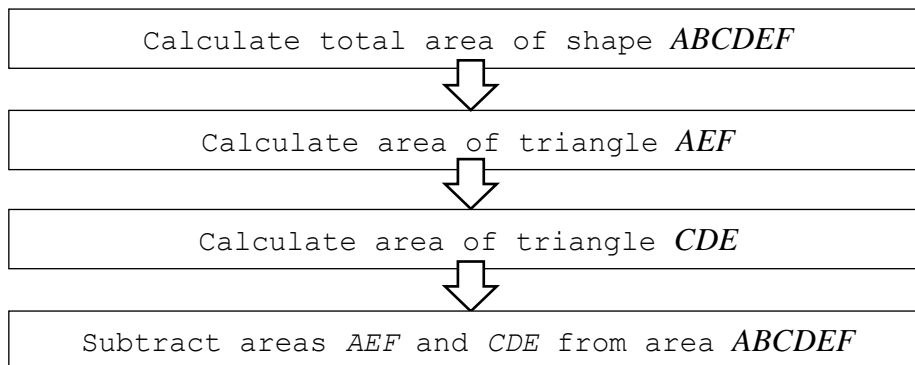

Shape  $ABCDEF$  can be broken down into two smaller rectangles  $ABFG$  and  $CDEG$  which have been labelled on the diagram. In order to calculate the area of these rectangles, we need to find missing side  $AB$ .

$$\begin{aligned}\text{Perimeter} &= AB + BC + CD + DE + EF + FA = 28 \\ &= AB + 2 + 3 + 6 + EF + 4 \\ &= AB + EF + 15 = 28\end{aligned}$$

$$EF = 3 + AB, \text{ so}$$

$$\begin{aligned}\text{Perimeter} &= AB + 3 + AB + 15 = 28 \\ &= 2AB = 10 \\ &= AB = 5 \text{ (added to diagram)}\end{aligned}$$

**Pearson Edexcel Level 1/Level 2 GCSE (9-1) in Mathematics (1MA1)  
Paper 2F/2H Common Questions**

**OR**

Perimeter of L shape = perimeter of Large rectangle

$$\text{Therefore } EF = (28 - 6 - 6) \div 2 = 8$$

$$AB = EF - 3 = 5$$

Area of  $ABCDEF$  = Area of  $ABFG$  and  $CDEG$

$$= (4 \times 5) + (3 \times 6) = 20 + 18 = 38\text{m}^2$$

$$\text{Area of triangle } AEF = \frac{8 \times 4}{2} = 16\text{m}^2$$

$$\text{Area of triangle } CDE = \frac{3 \times 6}{2} = 9\text{m}^2$$

$$\text{Area of shaded shape } ABCE = 38 - 16 - 9 = 13\text{m}^2$$

.....  
**(Total for Question 4 is 5 marks)**

## Paper 2H

- 7 Gina finds out the price of a CD box set in three different countries.

The price is

£98 in the UK  
 \$134.99 in the USA  
 €139.99 in Germany

The exchange rates are

£1 = \$1.43  
 €1 = £0.73

Gina wants to pay the cheapest price for the box set.

- (a) From which country should Gina buy the box set?  
 You must show how you get your answer.

Using arrow diagrams,

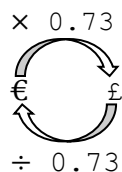
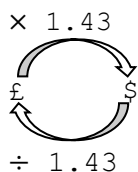

$$\begin{aligned} \$134.99 &= 134.99 \div 1.43 = \text{£}94.40 \\ \text{€}139.99 &= 139.99 \times 0.73 = \text{£}102.19 \end{aligned}$$

Comparing all prices in pounds, the box set is cheapest in the USA at £94.40.

(3)

Gina lives in the UK.

- (b) Why might your answer to (a) **not** be the best country for Gina to buy the box set from?

The postage costs will be more expensive if she purchases from the USA.

(1)

(Total for Question 7 is 4 marks)

8 Given that  $a : b = 8 : 5$  and  $b : c = 3 : 4$

find the ratio  $a : b : c$

Give your answer in its simplest form.

Using bar models,

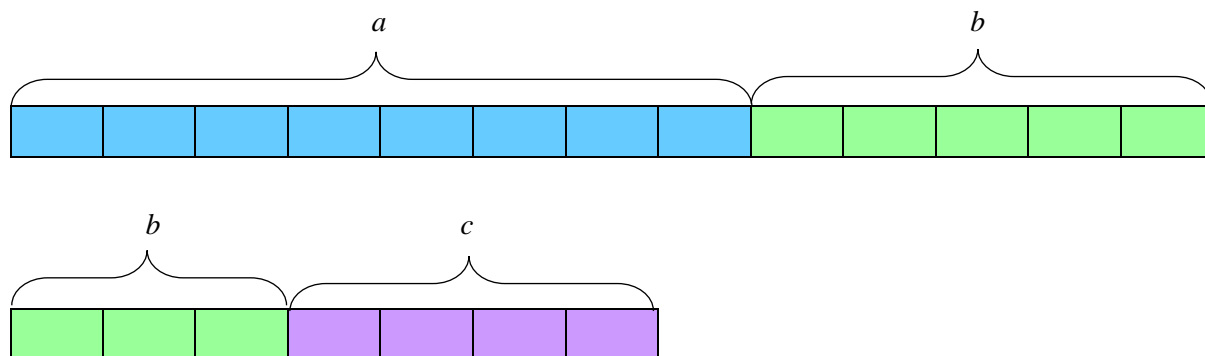

In order to compare all ratios,  $b$  needs to be the same in each.

Using a table to compare equivalent ratios,

$a : b$	$b : c$
8 : 5	3 : 4
16 : 10	6 : 8
<b>24 : 15</b>	9 : 12
	12 : 16
	<b>15 : 20</b>

Therefore the ratio  $a : b : c$  is 24 : 15 : 20

.....  
**(Total for Question 8 is 3 marks)**

- 11 The bottom of a ladder is on horizontal ground.  
The top of the ladder is leaning against a vertical wall.

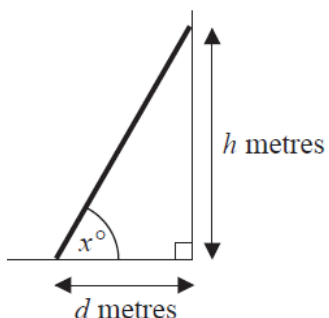

The bottom of the ladder is  $d$  metres from the wall.  
The top of the ladder is  $h$  metres above the ground.  
The angle between the ladder and the ground is  $x^\circ$

Some safety instructions say it is safe to climb the ladder when

$$h = 4d$$

- (a) Work out the value of  $x$  when  $h = 4d$

Using diagrams,

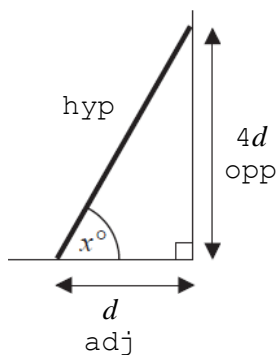

$$\tan x = 4d \div d = 4$$

$$\tan^{-1}(4) = 75.96^\circ$$

.....  
(3)

Some different safety instructions say the angle between the ladder and the ground should be  $75^\circ$

The ladder is moved so that  $x = 75$

(b) How does this affect the height,  $h$  metres, of the top of the ladder above the ground?

$75 < 75.96$ , so the angle between the ladder and the ground decreases. This also decreases the height  $h$ .

.....

**(1)**

**(Total for Question 11 is 4 marks)**

- 13** Alex wants to find out how many ducks there are in a park.

One day he puts a tag on each of 30 of the ducks.

The next day he catches 40 ducks.

8 of these ducks have tags on them.

- (i) Work out an estimate for the number of ducks in the park.

Using  $x$  for the unknown,

We know that 8 out of 40 ducks have tags on them, and we can assume that this proportion is the same for the total population to find an estimate for the number of ducks in the park.

Let  $x$  be the total number of ducks in the park.

$$\frac{8}{40} = \frac{30}{x}$$

$$8x = 1200$$

$$x = 150$$

**OR**

Use ratios

$$8:40 = 30:x \text{ OR } 8:30 = 40:x$$

$$x = 150$$

There are around 150 ducks in the park.

.....

Alex assumed that none of the tags fell off during the night.

- (ii) If Alex's assumption is wrong, explain how this could affect your answer to part (i).

If tags fell off in the night, the proportion used to estimate the number of ducks will have been incorrect and the number of ducks will have been overestimated.

**(Total for Question 13 is 4 marks)**

15

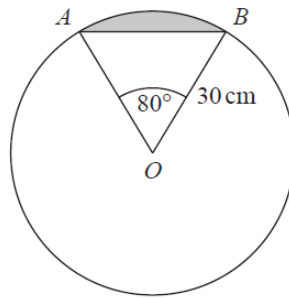

$AB$  is a chord of a circle centre  $O$ .

The radius of the circle is 30 cm.

Angle  $AOB = 80^\circ$

Work out what percentage of the area of the circle is shaded.

Using flow diagrams,

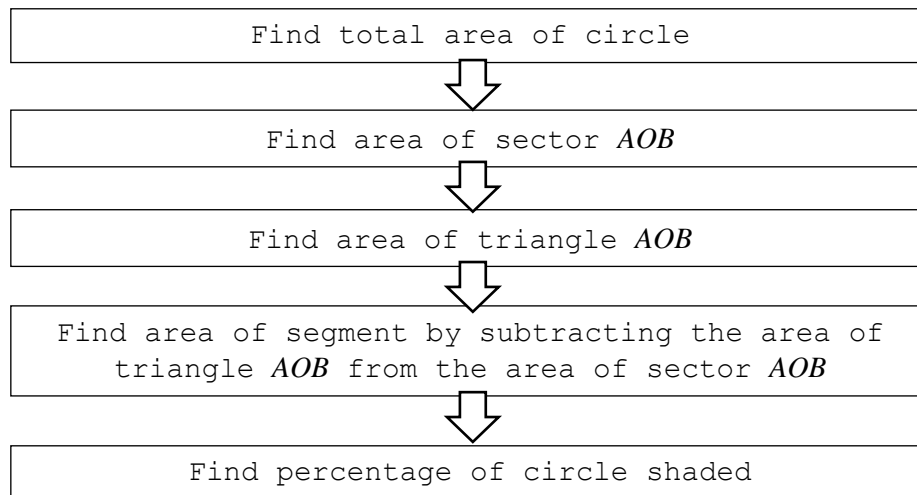

Area of circle  $= \pi r^2 = \pi \times 30^2 = 2827.43\text{cm}^2$

Area of sector  $AOB = \frac{80}{360} \times \pi \times 30^2 = 628.32\text{cm}^2$

Area of triangle  $AOB = \frac{1}{2} ab \sin C = \frac{1}{2} \times 30^2 \times \sin 80 = 443.16\text{cm}^2$

Area of segment  $= \text{Area of sector } AOB - \text{Area of triangle } AOB$   
 $= 628.32 - 443.16 = 185.16 \text{ cm}^2$

Percentage of the circle shaded  $= 185.16 \div 2827.43 \times 100\%$   
 $= 6.55\%$

.....%

**(Total for Question 15 is 5 marks)**

- 19**  $P$  has coordinates  $(-9, 7)$   
 $Q$  has coordinates  $(11, 12)$

$M$  is the point on the line segment  $PQ$  such that  $PM : MQ = 2 : 3$

Line  $L$  is perpendicular to the line segment  $PQ$ .

$L$  passes through  $M$ .

Find an equation of  $L$ .

Using diagrams

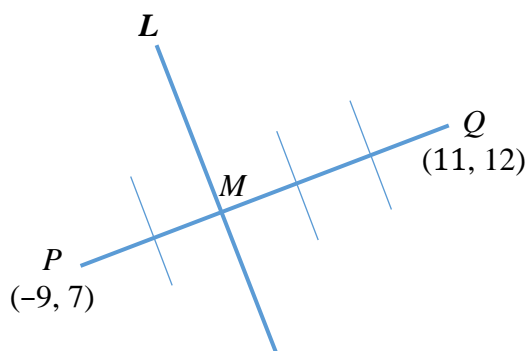

$$\text{Gradient of } PQ = (12 - 7) \div (11 - -9) = \frac{1}{4}$$

$$\text{Line } L \text{ is perpendicular to } PQ \text{ so the gradient is } -1 \div \frac{1}{4} = -4$$

$$\text{Point } M \text{ is } \frac{2}{5} \text{ along } PQ, \text{ so its x-coordinate is } -9 + (20 \times \frac{2}{5}) = -1$$

$$\text{and its y-coordinate is } 7 + (5 \times \frac{2}{5}) = 9$$

Substituting the gradient into the equation of a line gives

$$y = -4x + c$$

Substituting the coordinates of point  $M (-1, 9)$  into the equation,

$$9 = -4(-1) + c$$

$$c = 5$$

Therefore line  $L$  has equation  $y = -4x + 5$

.....  
**(Total for Question 19 is 5 marks)**

## Paper 3F

- 4 Packs of batteries cost £2.85 each.  
Ben has £45 to spend on batteries.

Ben buys as many packs of batteries as he can.  
Work out how much change he should get from £45

Using bar models,

1	2	3	4	...	15
£2.85	£5.70	£8.55	£11.40	...	£42.75

Ben can buy 15 packs of batteries.

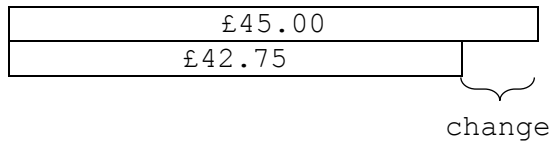

$$\text{Change from } \pounds 45 = \pounds 45.00 - \pounds 42.75 = \pounds 2.25$$

**OR**

Use a calculator to find  $\pounds 45.00 \div \pounds 2.85 = 15.79$  (2 d.p.)

Rounding down to give 15 packs of batteries.

$$15 \times \pounds 2.85 = \pounds 42.75$$

$$\text{Change} = \pounds 45.00 - \pounds 42.75 = \pounds 2.25$$

£ .....

**(Total for Question 4 is 3 marks)**

- 8 There are 375 pupils at a school.  
195 of the pupils are boys.

$\frac{3}{5}$  of the boys walk to school.

$\frac{2}{3}$  of the girls walk to school.

Work out how many pupils walk to school.

Using bar models,

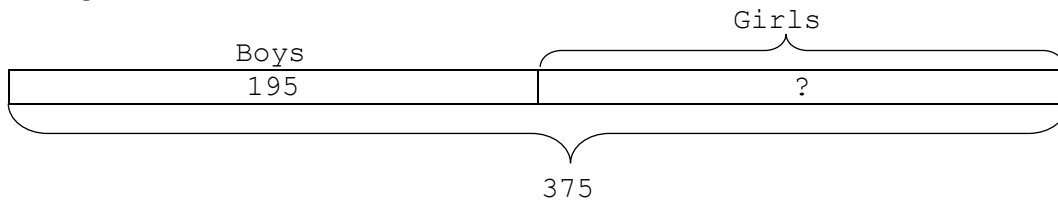

Total number of girls =  $375 - 195 = 180$

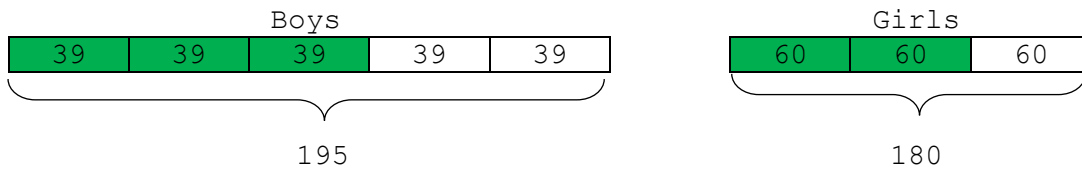

Boys that walk to school =  $39 + 39 + 39 = 117$

Girls that walk to school =  $60 + 60 = 120$

Total pupils that walk to school =  $117 + 120 = 237$

**OR**

Boys that walk to school =  $\frac{3}{5}$  of 195 =  $195 \div 5 \times 3 = 117$

Girls that walk to school =  $\frac{2}{3}$  of 180 =  $180 \div 3 \times 2 = 120$

Total pupils that walk to school =  $117 + 120 = 237$

.....  
**(Total for Question 8 is 3 marks)**

- 9 There are 19.5 litres of water in a water container.  
A cup holds 210 ml of water.

How many cups can be completely filled using the water in the water container?

There are 1000ml in 1 litre, so each cup holds 0.21 litre of water.

Using bar models,

1	2	3	4	...	92
0.21	0.42	0.63	0.84	...	19.32

Cups filled =  $19.5 \div 0.21 = 92.86$  (OR  $19500 \div 210$ )

92 cups can be filled using the water in the water container.

.....  
**(Total for Question 9 is 3 marks)**

- 13 Here is part of an advert for a driving school.

8 out of 10 of the people we teach pass the driving test first time
--

Ali talked to 56 people who had been taught to drive by the driving school.  
43 of these people passed the driving test first time.

Does this support what is said in the advert?  
You must show how you get your answer.

Of the people that Ali spoke to,  $\frac{43}{56}$  passed their driving test first time.

The driving school advertise that  $\frac{8}{10}$  people passed their driving test first time.

We can convert these fractions to percentages in order to compare them.

$$\frac{8}{10} = 8 \div 10 \times 100\% = 80\%$$

$$\frac{43}{56} = 43 \div 56 \times 100\% = 76.8\%$$

$76.8\% < 80\%$  which suggests fewer people pass first time than the advert suggests. Ali's data does not support what is said in the advert.

**(Total for Question 13 is 3 marks)**

## Paper 3F/3H Common Questions

---

- 1** Buses to Ashby leave a bus station every 24 minutes.  
Buses to Barford leave the same bus station every 20 minutes.

A bus to Ashby and a bus to Barford both leave the bus station at 7 30 am.

When will a bus to Ashby and a bus to Barford next leave the bus station at the same time?

Using a table,

Buses to Ashby	Buses to Barford
07:30	07:30
07:54	07:50
08:18	08:10
08:42	08:30
09:06	08:50
09:30	09:10
	09:30

A bus to Ashby and a bus to Barford next leave the bus station at 9:30am.

**OR**

Find LCM of 24 and 20 minutes

24, 48, 72, 96, **120**

20, 40, 60, 80, 100, **120**

120 minutes = 2 hours

07:30 + 2 hours = 09:30

.....  
**(Total for Question 1 is 3 marks)**

3 Kim, Laura and Molly share £385

The ratio of the amount of money Kim gets to the amount of money Molly gets is 2 : 5  
 Kim gets £105 less than Molly gets.

What percentage of the £385 does Laura get?

Using bar models,

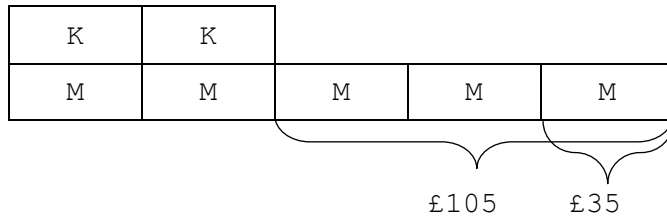

OR

Molly gets 3 more parts than Kim and those 3 parts = £105  
 So 1 part = £105 ÷ 3 = £35

Kim gets  $35 \times 2 = £70$

Molly gets  $35 \times 5 = £175$

Laura gets  $385 - (175 + 70) = £140$

$$\begin{aligned} \text{Percentage of £385 that Laura gets} &= \frac{140}{385} \times 100\% \\ &= 36.4\% \end{aligned}$$

..... %

**(Total for Question 3 is 4 marks)**

6

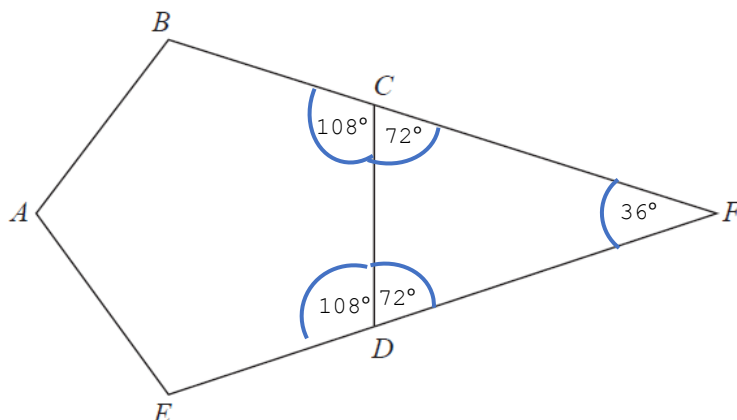

$ABCDE$  is a regular pentagon.  
 $BCF$  and  $EDF$  are straight lines.

Work out the size of angle  $CFD$ .  
You must show how you get your answer.

Using diagrams and bar models,

The interior angles of a pentagon =  $(3 \times 180^\circ) \div 5 = 108^\circ$

Angles in a straight line add to  $180^\circ$ , so

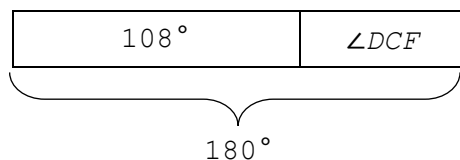

$$\angle DCF = 180^\circ - 108^\circ = 72^\circ \text{ (labelled on diagram)}$$

$ABCDE$  is a regular pentagon, so  $\angle EDC$  is also  $108^\circ$  and  
 $\angle FDC$  is also  $72^\circ$  (labelled on diagram)

Angles in a triangle add to  $180^\circ$  so

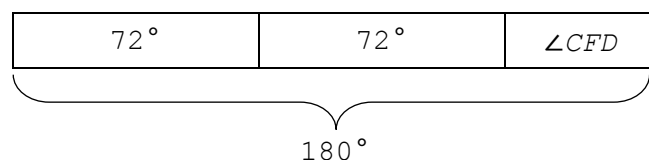

$$\angle CFD = 180^\circ - (72^\circ + 72^\circ) = 36^\circ$$

OR

$$\text{Exterior Angle of Regular Pentagon} = 360 \div 5 = 72^\circ$$

$$\text{Interior Angle of Regular Pentagon} = 180^\circ - \text{Exterior Angle} = 180^\circ - 72^\circ = 108^\circ$$

..... °

**(Total for Question 6 is 3 marks)**

---

- 7 A garden is in the shape of a rectangle,  $ABCD$ , and a semicircle.  
 $AD$  is the diameter of the semicircle.

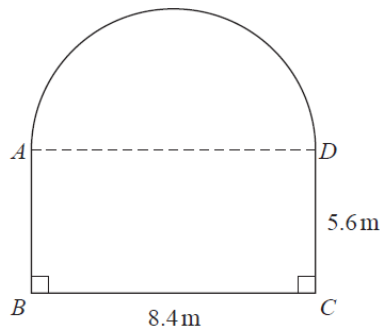

Carol is going to cover the garden with fertiliser.

A box of fertiliser costs £4.99

Carol has been told that one box of fertiliser will cover  $12 \text{ m}^2$  of garden.

- (a) Work out the cost of buying enough fertiliser to cover the garden completely.

Using flow diagrams,

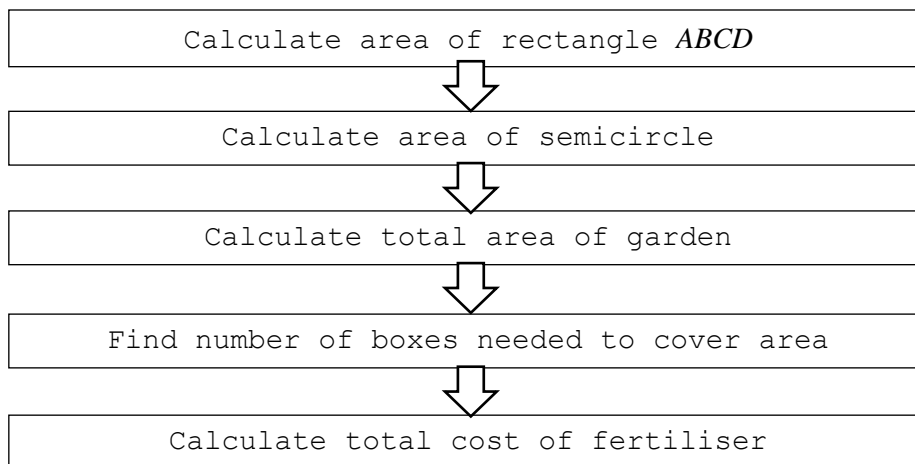

$$\text{Area of rectangle } ABCD = 8.4 \times 5.6 = 47.04\text{m}^2$$

$$\text{Area of semicircle} = (\pi \times 4.2^2) \div 2 = 27.71\text{m}^2$$

$$\text{Total area} = 47.04\text{m}^2 + 27.71\text{m}^2 = 74.75\text{m}^2$$

Using bar models to represent boxes of fertiliser,

12	12	12	12	12	12	12
12	24	36	48	60	72	84

**OR**

$$\text{Boxes required} = 74.75 \div 12 = 6.2$$

7 boxes are needed to cover  $74.75\text{m}^2$  of garden.

$$\text{Cost} = 7 \times \text{£}4.99 = \text{£}34.93$$

.....  
(5)

Carol finds out that one box of fertiliser will cover more than  $12 \text{ m}^2$  of garden.

(b) Explain how this might affect the number of boxes she needs to buy.

She may need to buy fewer boxes.

.....  
.....

(1)

**(Total for Question 7 is 6 marks)**

## Paper 3H

- 12 The diagram shows a piece of wood in the shape of a cuboid.

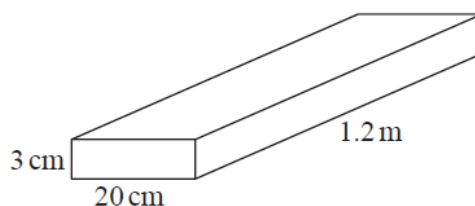

The piece of wood is 3 cm by 20 cm by 1.2 m.  
The mass of the piece of wood is 8 kg.

The piece of wood will float in sea water if the density of the wood is less than the density of the sea water.

In a large pool, 1 litre of sea water has a mass of 1030 g.

Will the piece of wood float in this pool?  
You must show how you get your answer.

Using flow diagrams,

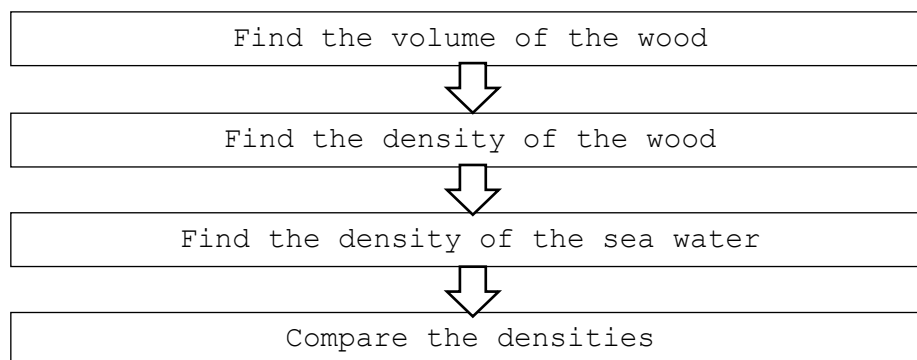

$$1.2\text{m} = 120\text{cm}$$

$$\text{Volume of the wood} = 3 \times 20 \times 120 = 7200\text{cm}^3$$

$$8\text{kg} = 8000\text{g}$$

$$\text{Density} = \text{mass} \div \text{volume}$$

$$\text{Density of the wood} = 8000 \div 7200 = 1.11$$

$$1 \text{ litre} = 1000\text{ml}$$

$$\text{Density of the sea water} = 1030 \div 1000 = 1.03$$

$$1.11 > 1.03$$

The density of the wood is greater than the density of the sea water, so the wood will not float.

**(Total for Question 12 is 4 marks)**

- 17 The diagram shows a solid metal cylinder.

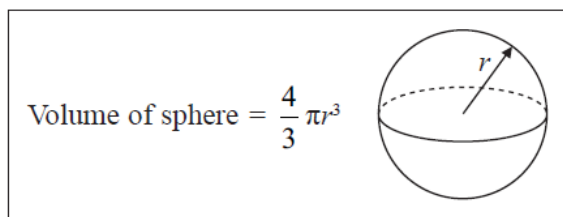
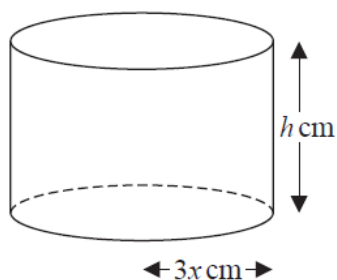

The cylinder has base radius  $3x$  cm and height  $h$  cm.

The metal cylinder is melted.

All the metal is then used to make 270 spheres.

Each sphere has a radius of  $\frac{1}{2}x$  cm.

Find an expression, in its simplest form, for  $h$  in terms of  $x$ .

$$\text{Volume of cylinder} = \pi r^2 \times h = \pi \times (3x)^2 \times h = 9\pi x^2 h$$

$$\text{Volume of sphere} = \frac{4}{3} \pi r^3 = \frac{4}{3} \times \pi \left(\frac{1}{2}x\right)^3 = \frac{1}{6} \pi x^3$$

$$\text{Volume of 270 spheres} = 270 \times \frac{1}{6} \pi x^3 = 45 \pi x^3$$

$$9\pi x^2 h = 45 \pi x^3$$

$$9h = 45x$$

$$h = 5x$$

.....  
(Total for Question 17 is 3 marks)

- 19 The diagram shows a pyramid with base  $ABC$ .

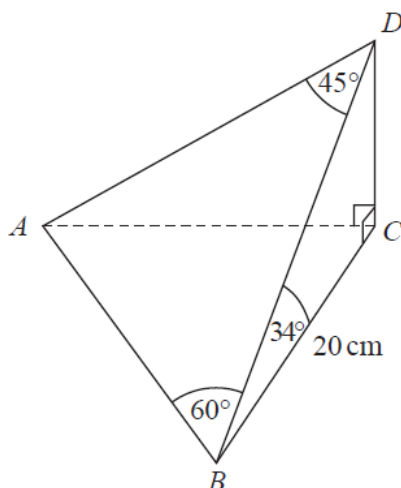

$CD$  is perpendicular to both  $CA$  and  $CB$ .

Angle  $CBD = 34^\circ$     Angle  $ADB = 45^\circ$     Angle  $DBA = 60^\circ$   
 $BC = 20$  cm.

Calculate the size of the angle between the line  $AD$  and the plane  $ABC$ .  
 Give your answer correct to 1 decimal place.

Using diagrams,

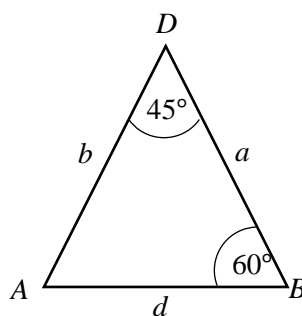
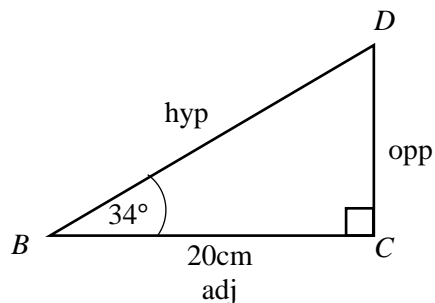

The question requires angle  $DAC$ . In order to do that, we first need to find sides  $AD$  and  $DC$ . We can find side  $DC$  from the first triangle and  $AD$  from the second triangle.

From the first triangle,

$$\tan 34 = DC \div 20$$

$$DC = 20 \tan 34 = 13.49 \text{ cm}$$

$BD$  is also needed to find  $AD$ , so

$$\cos 34 = 20 \div BD$$

$$BD = 20 \div \cos 34 = 24.12 \text{ cm}$$

$AD$  can be found using the sine rule on the 2<sup>nd</sup> triangle

$$b \div \sin B = a \div \sin A$$

$$AD \div \sin 60 = BD \div \sin A$$

$$AD \div \sin 60 = 24.12 \div \sin(180 - 45 - 60) = 24.12 \div \sin 75$$

$$AD = \sin 60 \times 24.12 \div \sin 75 = 21.63\text{cm}$$

$$\sin DAC = CD \div AD = 13.49 \div 21.63 = 0.62$$

$$\angle DAC = \sin^{-1}(0.62) = 38.6^\circ \text{ (to 1 dp)}$$

..... °  
**(Total for Question 19 is 5 marks)**

20 For all values of  $x$

$$f(x) = 2x - 3 \quad \text{and} \quad g(x) = x^2 + 2$$

(a) Find  $g(-4)$

$$g(-4) = (-4)^2 + 2 = 16 + 2 = 18$$

(1)

(b) Show that  $gf(x) = 4x^2 - 12x + 11$

$$\begin{aligned} gf(x) &= (2x - 3)^2 + 2 = 4x^2 - 12x + 9 + 2 \\ &= 4x^2 - 12x + 11 \end{aligned}$$

(2)

(c) Solve  $fg(x) = gf(x)$

$$fg(x) = 2(x^2 + 2) - 3 = 2x^2 + 4 - 3 = 2x^2 + 1$$

From previous question,  $gf(x) = 4x^2 - 12x + 11$ , so

$$4x^2 - 12x + 11 = 2x^2 + 1$$

$$2x^2 - 12x + 10 = 0$$

$$2x^2 - 2x - 10x + 10 = 0$$

$$2x(x - 1) - 10(x - 1) = 0$$

$$(2x - 10)(x - 1) = 0$$

$$2x - 10 = 0$$

$$x = 5$$

$$x - 1 = 0$$

$$x = 1$$

OR

$$2x^2 - 12x + 10 = 0$$

Half all coefficients to give  $x^2 - 6x + 5 = 0$

Then factorise to give

$$(x - 5)(x - 1) = 0$$

$$x - 5 = 0$$

$$x = 5$$

$$x - 1 = 0$$

$$x = 1$$

.....  
**(4)**

**(Total for Question 20 is 7 marks)**