

Write your name here

Surname

Other names

Centre Number

Candidate Number

Edexcel GCSE

Methods in Mathematics

Unit 2: Methods 2

Foundation Tier

Practice Paper

Time: 1 hour 45 minutes

Paper Reference

5MM2F/01

You must have: Ruler graduated in centimetres and millimetres, protractor, pair of compasses, pen, HB pencil, eraser, calculator. Tracing paper may be used.

Total Marks

Instructions

- Use **black** ink or ball-point pen.
- **Fill in the boxes** at the top of this page with your name, centre number and candidate number.
- Answer **all** questions.
- Answer the questions in the spaces provided
– *there may be more space than you need.*
- **Calculators may be used.**
- If your calculator does not have a π button, take the value of π to be 3.142 unless the question instructs otherwise.



Information

- The total mark for this paper is 100
- The marks for **each** question are shown in brackets
– *use this as a guide as to how much time to spend on each question.*
- Questions labelled with an **asterisk** (*) are ones where the quality of your written communication will be assessed
– *you should take particular care on these questions with your spelling, punctuation and grammar, as well as the clarity of expression.*

Advice

- Read each question carefully before you start to answer it.
- Keep an eye on the time.
- Try to answer every question.
- Check your answers if you have time at the end.

Turn over ►

W41076A

©2012 Pearson Education Ltd.

2/2



PEARSON

GCSE Mathematics 2MM01

Formulae: Foundation Tier

**You must not write on this formulae page.
Anything you write on this formulae page will gain NO credit.**

Area of trapezium = $\frac{1}{2}(a + b)h$

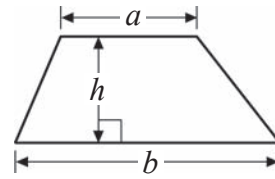

Volume of prism = area of cross section \times length

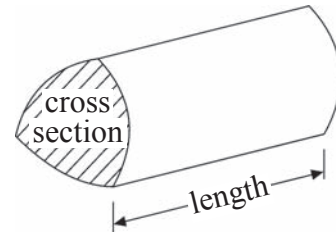

Answer ALL questions.

Write your answers in the spaces provided.

You must write down all stages in your working.

- 1 Write these numbers in order of size.
Start with the smallest number.

0.62 0.26 0.66 0.2 0.06

.....

(Total for Question 1 is 1 mark)

- 2 Work out

(a) 9.1^2

.....
(1)

(b) -7×-9

.....
(1)

(c) $40 - 12 \div 4$

.....
(1)

(d) $(34.1 - 8.7) \times 2.5$

.....
(2)

(Total for Question 2 is 5 marks)



3 (a) Complete this sentence.

An octagon has straight sides. (1)

(b) Complete this sentence.

A regular hexagon has 6 straight sides and 6 angles. (1)

The diagram shows a polygon.

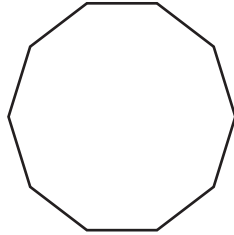

(c) Write down the name of this polygon.

..... (1)

You can use this rule to work out the sum of the interior angles, in degrees, of a polygon.

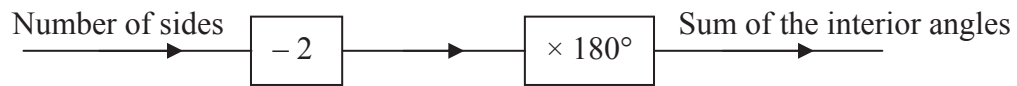

(d) Work out the sum of the interior angles for a polygon with 7 sides.

..... (3)

The sum of the interior angles of another polygon is 1800

(e) How many sides does this polygon have?

..... (3)

(Total for Question 3 is 9 marks)



4 (a) Work out the difference between -15°C and -31°C .

..... $^{\circ}\text{C}$
(1)

(b) Work out the difference between -9°C and 5°C .

..... $^{\circ}\text{C}$
(1)

(c) Find the temperature that is exactly half way between -11°C and 3°C .

..... $^{\circ}\text{C}$
(2)

(Total for Question 4 is 4 marks)

5 (a) Work out $5 \times \sqrt{3}$

Give your answer as a decimal.

Write down all the figures from your calculator display.

.....
(1)

(b) Work out $\frac{240}{15 \times 4}$

.....
(2)

(Total for Question 5 is 3 marks)

6 $A = bc$

(a) Work out the value of A when $b = 4$ and $c = 5$

.....
(1)

$P = 2a + 2b$

(b) Work out the value of P when $a = 7$ and $b = 12$

.....
(2)

(Total for Question 6 is 3 marks)



- 7 Bag A contains x counters.
Bag B contains 4 more counters than bag A.

Write down a formula for the total number of counters, T , in the two bags.

.....
(Total for Question 7 is 3 marks)

- 8 (a) Rob thinks of a number.
He subtracts 7 from his number.
His answer is 5

What number did Rob first think of?

.....
(1)

- (b) Ali thinks of a number.
She multiplies her number by 3
She then adds 5
Her answer is 32

What number did Ali first think of?

.....
(2)

(Total for Question 8 is 3 marks)



9 (a) Write 54% as a fraction.
Give your fraction in its simplest form.

.....
(2)

(b) Write $\frac{1}{10}$ as a decimal.

.....
(1)

(c) Work out $\frac{1}{5}$ of 80

.....
(1)

(d) Work out 10% of 80

.....
(1)

*(e) Which is bigger $\frac{3}{4}$ or 0.8 or 77%?

Give a reason for your answer.

(3)

(Total for Question 9 is 8 marks)



10 (a) Here is a table for a two-stage number machine.

The machine divides by 2 and then adds 5



Complete the table.

Input	Output
2	6
8	9
12
23
.....	73

(3)

Here is another two-stage number machine.



When the input is 6 the output is 38.

(b) Complete the number machine.

(2)

(Total for Qusetion 10 is 5 marks)

11 Work out 25% of 600

.....

(Total for Question 11 is 2 marks)



12 (a) Write 8 out of 18 as a fraction.
Write your fraction in its simplest form.

.....
(2)

(b) Shade $\frac{2}{5}$ of this shape.

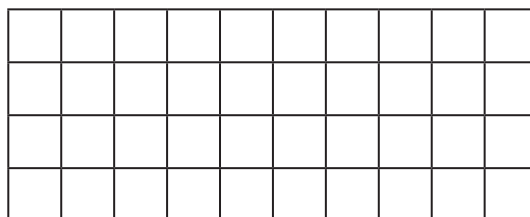

(2)

Here is another rectangle.

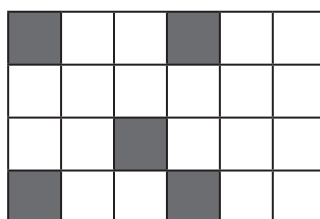

Some **more** squares are shaded so that the

the number of shaded squares : the number of unshaded squares = 3 : 5

(c) How many more squares are shaded?

.....
(2)

(Total for Question 12 is 6 marks)



13 Here is a cuboid.

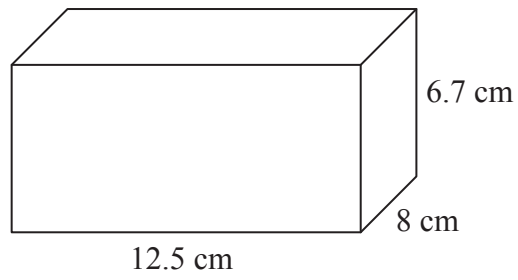
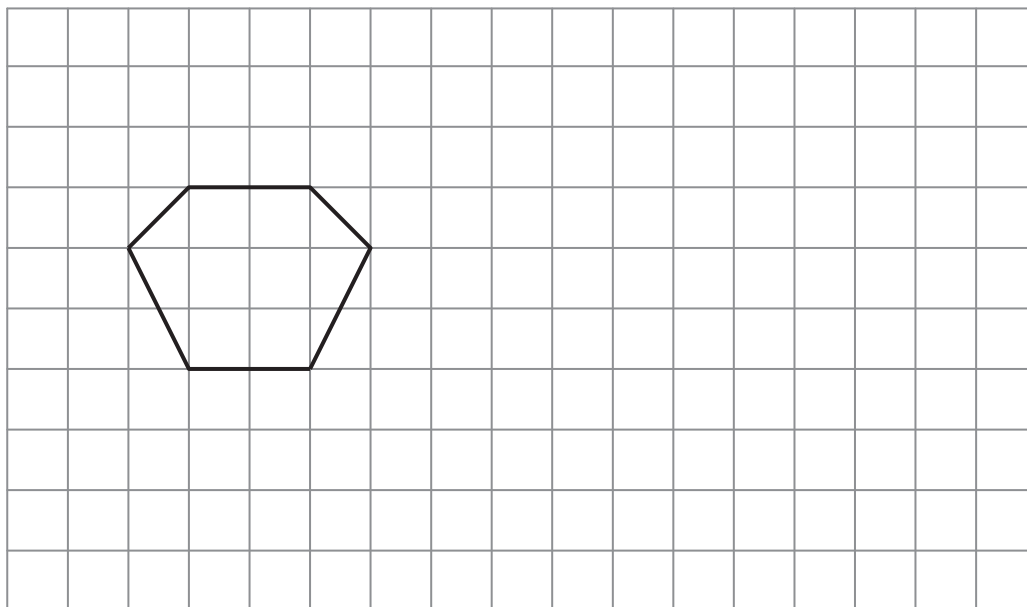

Diagram **NOT**
accurately drawn

Work out the volume of the cuboid.

.....
(Total for Question 13 is 3 marks)

14 On the grid, show how the shape tessellates.
You must draw at least 6 shapes.



(Total for Question 14 is 2 marks)



*15

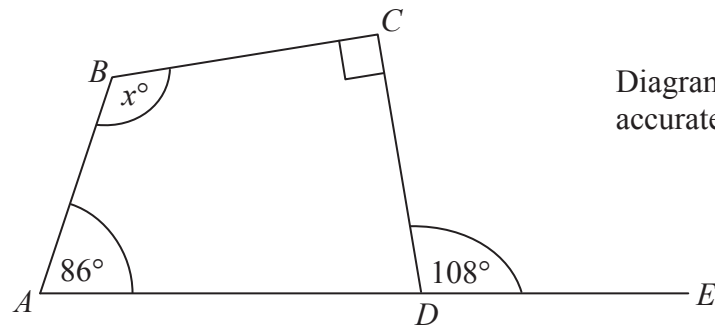

Diagram **NOT** accurately drawn

$ABCD$ is a quadrilateral.
 ADE is a straight line.

Work out the value of x .
Give reasons for your answer.

(Total for Question 15 is 4 marks)

16 The two rectangles are mathematically similar.

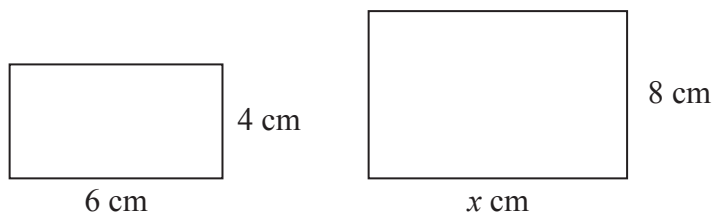

Diagram **NOT** accurately drawn

Work out the value of x .

$x = \dots\dots\dots$

(Total for Question 16 is 2 marks)





***17** A bag contains some counters.

5% of the counters are blue.

$\frac{5}{8}$ of the counters are red.

$\frac{1}{5}$ of the counters are yellow.

The rest of the counters are green.

What percentage of the counters in the bag are green?

(Total for Question 17 is 4 marks)

18 5 kg of apples costs £4.30

Work out the cost of 7 kg of these apples.

£

(Total for Question 18 is 2 marks)



*19

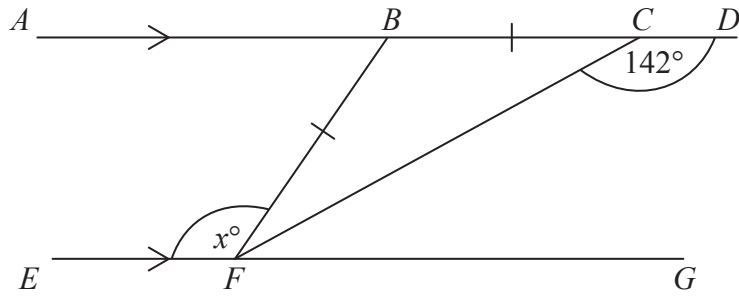

Diagram **NOT**
accurately drawn

AD is parallel to EG .

$BC = BF$.

Angle $FCD = 142^\circ$.

Work out the size of the angle marked x° .

Give reasons for your answer.

(Total for Question 19 is 4 marks)



W 4 1 0 7 6 A 0 1 3 2 0

20 Here is a solid triangular prism.

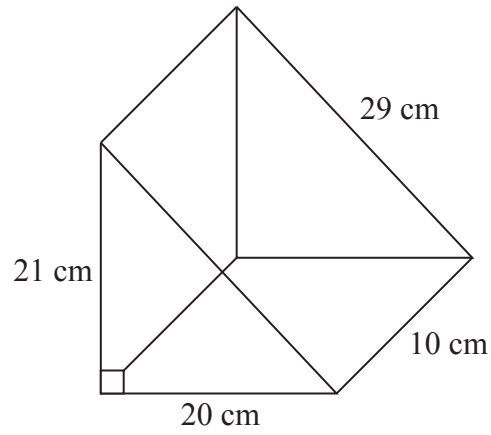

Diagram **NOT**
accurately drawn

Work out the total surface area of the prism.

..... cm²

(Total for Question 20 is 4 marks)

21 Divide £200 in the ratio 3 : 5

.....

(Total for Question 21 is 3 marks)



22 Increase £820 by 35%

£
(3)

(Total for Question 22 is 3 marks)

23 $W = 3x^2 - 5x$
 $x = -8$

(a) Work out the value of W .

$W =$
(2)

(b) Make c the subject of the formula $f = 3c - t$

.....
(2)

(Total for Question 23 is 4 marks)



24 The diagram shows a rectangle with a circle cut out.

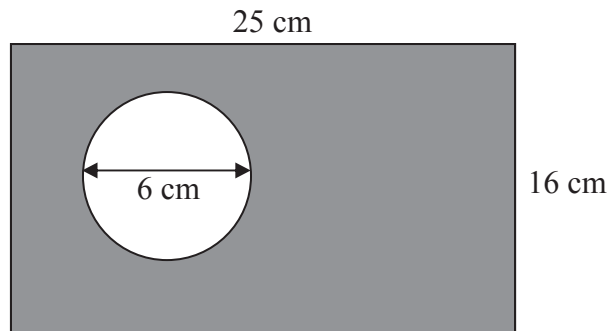

Diagram **NOT** accurately drawn

The rectangle has length 25 cm and width 16 cm.
The circle has diameter 6 cm.

Work out the shaded area.
Give your answer correct to 3 significant figures.

..... cm²

(Total for Question 24 is 4 marks)

25 A is the point (2, 3).
 B is the point (7, 11).

Work out the length AB .
Give your answer correct to 3 significant figures.

Diagram **NOT** accurately drawn

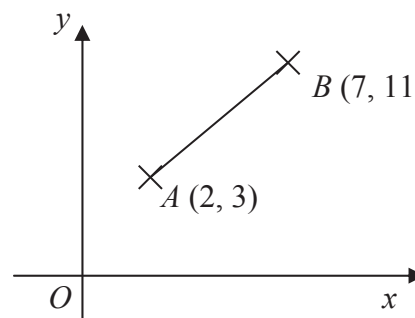

.....

(Total for Question 25 is 3 marks)



26 The diagram shows a rectangle.

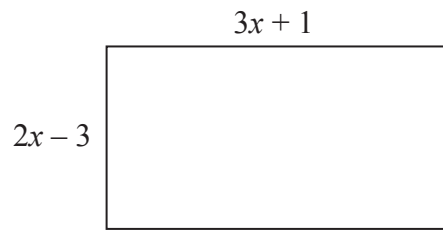

Diagram **NOT**
accurately drawn

All measurements on the diagram are in centimetres.

The perimeter of the rectangle is less than 55 cm.

(a) Show that $10x - 4 < 55$

(3)

x is an integer.

(b) Find the greatest possible value of x .

.....
(3)

(Total for Question 26 is 6 marks)

TOTAL FOR PAPER IS 100 MARKS





BLANK PAGE



BLANK PAGE





BLANK PAGE

