

Write your name here

Surname

Other names

**Pearson**  
**Edexcel GCSE**

Centre Number

--	--	--	--	--

Candidate Number

--	--	--	--

# Computer Science

## Paper 1: Principles of Computer Science

Wednesday 8 June 2016 – Morning  
**Time: 2 hours**

Paper Reference

**1CP0/01**

**You do not need any other materials.**

Total Marks

### Instructions

- Use **black** ink or ball-point pen.
- Use of a calculator is prohibited.
- **Fill in the boxes** at the top of this page with your name, centre number and candidate number.
- Answer **all** questions.
- Answer the questions in the spaces provided  
– *there may be more space than you need.*

### Information

- The total mark for this paper is 90.
- The marks for **each** question are shown in brackets  
– *use this as a guide as to how much time to spend on each question.*
- Questions labelled with an **asterisk** (\*) are ones where the quality of your written communication will be assessed  
– *you should take particular care on these questions with your spelling, punctuation and grammar, as well as the clarity of expression.*

### Advice

- Read each question carefully before you start to answer it.
- Try to answer every question.
- Check your answers if you have time at the end.

Turn over ►

P47341A

©2016 Pearson Education Ltd.

1/1/1/1/1/1



**PEARSON**

Answer ALL questions. Write your answers in the spaces provided.

Some questions must be answered with a cross in a box ☒. If you change your mind about an answer, put a line through the box ☒ and then mark your new answer with a cross ☒.

1 (a) Computer networks are valuable to many businesses and individuals.

(i) State the purpose of network protocols.

(1)

Here is a diagram showing the Internet as a network of networks. Each square represents a computing device.

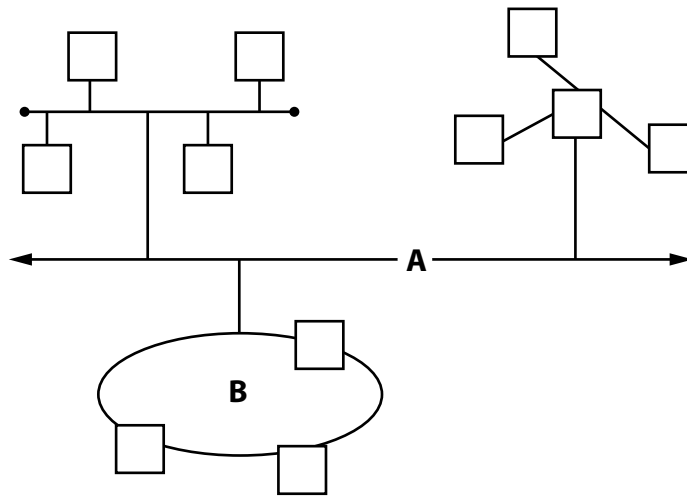

(ii) State the name of the high-speed Internet infrastructure shown at **A**.

(1)

(iii) State the name of the network topology shown at **B**.

(1)

DO NOT WRITE IN THIS AREA

DO NOT WRITE IN THIS AREA

DO NOT WRITE IN THIS AREA



(iv) Identify the type of network used in each situation.

(4)

Situation	LAN	WAN	PAN	VPN
A delivery driver uses a hands-free car kit to connect to his mobile phone.	<input type="checkbox"/>	<input type="checkbox"/>	<input type="checkbox"/>	<input type="checkbox"/>
A dental nurse uses a computer to look at digital x-rays stored on a server in the basement of the building.	<input type="checkbox"/>	<input type="checkbox"/>	<input type="checkbox"/>	<input type="checkbox"/>
A manager, working from home, is able to access all the computers in his company as if he was in the company office.	<input type="checkbox"/>	<input type="checkbox"/>	<input type="checkbox"/>	<input type="checkbox"/>
An office in Tokyo sends emails to all customers, whether they are in New York, Paris or Delhi.	<input type="checkbox"/>	<input type="checkbox"/>	<input type="checkbox"/>	<input type="checkbox"/>

(b) Data transmitted over a network is sometimes encrypted.

(i) State **one** reason why data encryption is used on a network.

(1)

(ii) Complete the table using a Caesar cipher to encrypt and decrypt the text.

(2)

Plain text	Shift	Cipher text
digit	+3	
	-2	zglypw



(c) Binary numbers are used to represent data in programs.

(i) Complete the table by adding these two positive 8-bit binary integers.

(1)

0	1	1	1	0	0	1	0
0	0	1	0	0	0	1	1

(ii) Convert the 8-bit binary 01101110 to hexadecimal.

(1)

(iii) Convert the hexadecimal number C4 to 8-bit binary.

(1)

(iv) Write an arithmetic expression to show that 256 different numbers can be represented in 8 bits.

(1)

(d) (i) State **one** characteristic of a lossy compression algorithm.

(1)



(ii) Identify an example of lossy compression.

(1)

- A GIF
- B JPEG
- C ZIP
- D TIFF

(e) Binary digits can represent Cartesian coordinates.

A turtle is used to draw on a Cartesian coordinate system. The turtle begins at the origin.

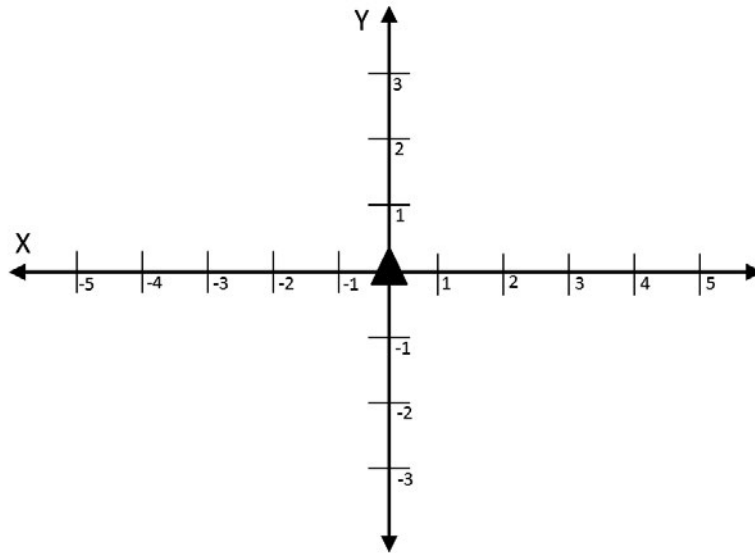

The turtle follows this program.

```
FORWARD 3
TURN RIGHT 90
FORWARD 5
TURN LEFT 180
FORWARD 3
```

Write the final location of the turtle using Cartesian coordinates.

(2)

.....

.....

**(Total for Question 1 = 18 marks)**

DO NOT WRITE IN THIS AREA

DO NOT WRITE IN THIS AREA

DO NOT WRITE IN THIS AREA



- 2 Charles is a computer programmer for a company that sells digital products through the Internet.

He must be aware of the ethical and legal issues arising from the use of computers.

- (a) Identify the legislation that applies in each situation.

(3)

Situation	EU Cookie Law (e-Privacy Directive)	Computer Misuse Act	Copyright, Designs and Patents Act
A teenager was given a computer game for her birthday. She gives a copy of the game to her friend.	<input type="checkbox"/>	<input type="checkbox"/>	<input type="checkbox"/>
A university student tries to gain access to government computers, even though he is not a registered user.	<input type="checkbox"/>	<input type="checkbox"/>	<input type="checkbox"/>
A company has been storing small files on users' computers to track the use of its website, but is not telling them.	<input type="checkbox"/>	<input type="checkbox"/>	<input type="checkbox"/>

- (b) Charles is writing program code for the IT department to use.

- (i) Identify the type of programming language **most** suitable for each situation.

(4)

Situation	High-level programming language	Low-level programming language
Keeping a list of computers that need fixing.	<input type="checkbox"/>	<input type="checkbox"/>
Increasing the speed of part of a computer program so that it runs in 1 hour instead of 20 hours.	<input type="checkbox"/>	<input type="checkbox"/>
Keeping track of how many users log into the company's file servers each day.	<input type="checkbox"/>	<input type="checkbox"/>
Writing a program for a new computer processor.	<input type="checkbox"/>	<input type="checkbox"/>



Here is some pseudocode.

```
10 SET aNum TO 0
11 SET userNum TO 0
12
13 WHILE userNum = 0 DO
14     SEND "Enter a number:" TO DISPLAY
15     RECEIVE userNum FROM (INTEGER) KEYBOARD
16 END WHILE
17
18 IF userNum < 10 THEN
19     SET aNum TO cubeNum (userNum)
20 ELSE
21     SET aNum TO userNum
22 END IF
23 SEND aNum TO DISPLAY
24
25 FUNCTION cubeNum (aNum)
26 BEGIN FUNCTION
27     SET total TO aNum * aNum * aNum
28     RETURN total
29 END FUNCTION
```

(ii) State the coding technique that Charles could use to make the pseudocode easier to understand.

(1)

(iii) State the name of the subprogram shown in the pseudocode.

(1)

(iv) State the range of line numbers that show a selection statement.

(1)

(v) State a line number on which the variable aNum is a local variable.

(1)

(vi) State a line number on which the variable aNum is a global variable.

(1)



(c) Charles is preparing to write program code.

- (i) Complete the table to show the place value of the 1s to the right of the decimal in this binary real number.

(3)

Place value	4	2	1	.					
	0	1	0	.	1	1	0	0	0

Convert this binary real number to denary.

.....

.....

.....

- (ii) State the number of bits in a nibble.

(1)

.....

- (iii) Write an arithmetic expression to show the time needed to transmit a 10 KB file at 10 Mbps.

(2)

.....

.....

.....

.....

**(Total for Question 2 = 18 marks)**





DO NOT WRITE IN THIS AREA

DO NOT WRITE IN THIS AREA

DO NOT WRITE IN THIS AREA

**3** Shaneela is designing and coding a website. The files she creates will be stored on a computer.

(a) File management is a function that an operating system performs.

Describe how an operating system organises files.

(3)

.....

.....

.....

.....

.....

.....

.....

.....

.....

.....

(b) The pages that Shaneela designs will be accessed via a web server.

(i) Describe how someone will access the pages using the client-server model.

(2)

.....

.....

.....

.....



Here is a web page shown in a browser.

# Tootle Tools

## Sale Wrenches

- Socket
- Open Ended

## Sale Pliers

- Thin-Nose
- Needle-Nose

(ii) Write the HTML code needed to format the text "Socket" and "Open Ended" as shown above.

(3)

```
<html>  
<body>
```

```
</body>  
</html>
```

DO NOT WRITE IN THIS AREA

DO NOT WRITE IN THIS AREA

DO NOT WRITE IN THIS AREA



(c) Shaneela is planning to use libraries in the code for the website.

(i) State **two** reasons for using libraries in code.

(2)

1 .....

.....

.....

2 .....

.....

.....

In Shaneela's program, the days of the week are numbered 1 for Monday, 2 for Tuesday, 3 for Wednesday, 4 for Thursday, 5 for Friday, 6 for Saturday and 7 for Sunday.

She is writing code to determine if a numerical value represents a weekday or weekend day.

(ii) Complete the following pseudocode to show the logical operations required to produce the correct output.

(4)

```

IF day >= 1  day <= 5 THEN
    SEND "weekday" TO DISPLAY
ENDIF
IF day = 6  day = 7 THEN
    SEND "weekend" TO DISPLAY
IF  (day >= 1  day <= 7) THEN
    SEND "error" TO DISPLAY
ENDIF
  
```



(d) The website allows users to search a database.

Here is a table from the database.

tblProduct		
id	description	supplier
A209	Slip-Joint Pliers	Warwick's
A298	Open Ended Wrench	Warwick's
G126	Hook Spanner	Plumber's World
G212	Pipe Wrench Pliers	A & B Hardware
G397	Locking Pliers	A & B Hardware
G423	Closed Ended Wrench	Plumber's World
M315	Socket Wrench	A & B Hardware
M581	Needle-Nose Pliers	A & B Hardware
Q145	Socket Wrench	A & B Hardware
Q363	Thin-Nose Pliers	Plumber's World
Q441	Adjustable Spanner	Plumber's World
Q488	Adjustable Wrench	Carpenter's Corner
Q596	Wire Strippers	Plumber's World

Write an SQL statement that will report the 'id' and 'description' fields for all records where the 'id' begins with the letter G. Sort the result by 'id' in ascending order.

(4)

**(Total for Question 3 = 18 marks)**



DO NOT WRITE IN THIS AREA

DO NOT WRITE IN THIS AREA

DO NOT WRITE IN THIS AREA

4 Manuel is interested in understanding the relationship between hardware and software.

(a) Describe what is meant by the term 'stored program concept'.

(2)

.....

.....

.....

.....

.....

.....

.....

(b) Computing machines can take many forms and can be based on various models.

(i) Describe what is meant by the term 'virtual machine'.

(2)

.....

.....

.....

.....

.....

.....

.....

(ii) Explain the difference between the sequential and parallel computational models.

(4)

.....

.....

.....

.....

.....

.....

.....

.....

.....

.....



(c) Manuel is writing a program to help pupils with their maths revision.

Here is some pseudocode for an algorithm that calculates the area of a circle, with radius of 5 units. It uses a subprogram.

```
calcCircleArea ()  
  
PROCEDURE calcCircleArea ()  
BEGIN PROCEDURE  
    SET area TO Pi * 5 * 5  
    SEND area TO DISPLAY  
END PROCEDURE
```

Manuel wants to change the pseudocode so that the area of any circle can be calculated using `calcCircleArea`.

(i) Write the changed pseudocode in the box below.

(3)



Manuel is writing a binary search routine to search for an individual pupil in a list of all pupil numbers.

Here is the list of pupil numbers.

837, 1529, 1683, 2245, 3901, 3921, 4524

- (ii) Complete the table showing the pupil numbers visited and the associated sublists when using a binary search to locate the pupil number 1683.

(5)

Pupil number visited	Sublist

Manuel is working on logic for an exclusive OR operator, often known as XOR. This logical operator can be implemented using AND, OR, and NOT.

- (iii) Complete this truth table to show Q.

(3)

A	B	R = A OR B	S = NOT (A AND B)	Q = R AND S
0	0			
0	1			
1	0			
1	1			

(Total for Question 4 = 19 marks)



5 Artificial intelligence is an emerging trend in computer science.

\*(a) Discuss the use of artificial intelligence by describing some of its characteristics, the ways in which it may be used and the ethical issues associated with its use.

(6)

Area with horizontal dotted lines for writing the answer.

DO NOT WRITE IN THIS AREA

DO NOT WRITE IN THIS AREA

DO NOT WRITE IN THIS AREA





DO NOT WRITE IN THIS AREA

DO NOT WRITE IN THIS AREA

DO NOT WRITE IN THIS AREA

**BLANK PAGE**



(b) Assembly language can be used to implement artificial intelligence algorithms.

Here is a subset of an assembly language instruction set.

Operation	Assembler	Action
Multiply	MUL {condition} Rd, Rm, Rs	Multiplies the contents of Register m by the contents of Register s and stores the result in Register d
Subtract	SUB {condition} Rd, Rn, #<value>	Subtracts <value> from the contents of Register n and stores the result in Register d
Move	MOV {condition} Rd, #<value>	Moves <value> into Register d
	MOV {condition} Rd, Rm	Moves the contents of Register m into Register d
Compare	CMP {condition} Rn, #<value>	Compares <value> with the value in Register n
Branch	B {condition} label	Branch

Condition - Mnemonic	Description
EQ	Equal

Here is an assembly language program.

Line number			
245		MOV	R3,#1
246		MOV	R4,#2
247		MOV	R5,#4
248	L1:	CMP	R5,#0
249		BEQ	L10
250		MUL	R3,R3,R4
251		SUB	R5,R5,#1
252		B	L1
253	L10:		



- (i) Complete the trace table showing the changes in the values of R3, R4 and R5 during execution of the program.

(5)

R3	R4	R5

- (ii) State the purpose of this algorithm.

(1)

The assembly language instructions, like those above, are made up of two distinct parts.

- (iii) Using the instruction `MOV R4,#2` as an example, state the name of each part of this instruction.

(2)

`MOV` .....

`R4,#2` .....



The assembly language program is repeated here.

Line number			
245		MOV	R3,#1
246		MOV	R4,#2
247		MOV	R5,#4
248	L1:	CMP	R5,#0
249		BEQ	L10
250		MUL	R3,R3,R4
251		SUB	R5,R5,#1
252		B	L1
253	L10:		

(iv) Use any programming language or notation that you know to complete the high-level language equivalent of the assembly language program.

(3)

**(Total for Question 5 = 17 marks)**

**TOTAL FOR PAPER = 90 MARKS**

