

Component 1 Three-dimensional Design

Standard Mark – 59

	A01	A02	A03	A04	TOTAL
Mark	15	15	14	15	59
Level	5	5	5	5	
	Fully confident and assured ability	Fully confident and assured ability	Mostly confident and assured ability	Fully confident and assured ability	

Examiner comments:

The candidate's focused submission of sculptural responses to the overarching coursework theme of 'merging forms', is underpinned by comprehensive investigations into the work of relevant Fine Artists and Designers, including Kandinsky, Kusama and Mihich (A01). Confident and assured development of ideas through drawing and constructing maquettes (A02), enables the candidate to create a series of sculptures that reflect a growing interest in pattern and mark-making (A03). Further experimentations with acrylic sheet shapes (A02) (A03) support the candidate's visual journey and result in a convincing final outcome (A04).

Keyword descriptors from the taxonomy:

Advanced Refined
 Convincing Resolved
 Comprehensive Risk-taking

Techniques:

- Drawing in black and white.
- ~~Water~~ Water colour painting.
- Doodling.
- Sketching.

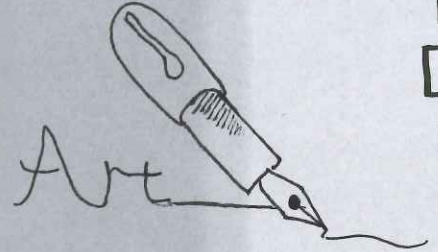

"Wide,
curved,

tall or
long,

Styles

So many
shapes
but

Variety of ways
→ expressing merging forms.
"none are wrong."

MERG

- Abstract Expressionism.
- Classicism.
- Expressionism.
- Baroque.
- Cubism.
- Conceptual art.

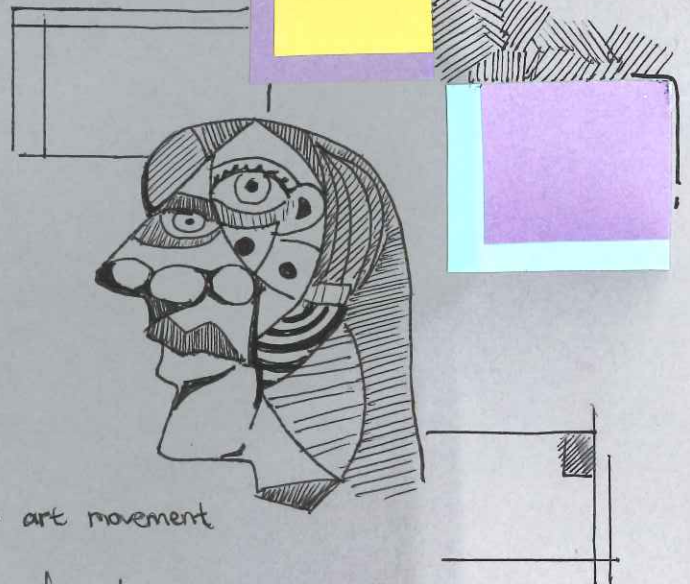
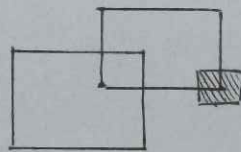

→ Early - 20th-century avantgarde art movement

→ Revolutionized European painting and sculpture

→ Objects are analyzed, broken up and reassembled in an abstracted form.

↳ Want to combine cubism with merging forms, since cubism has the idea of broken up objects, which can be transformed into merging forms, putting together the objects.

Artists!

- Franz Weïssmann.
- David Bill.
- Kandinsky.
- Katsushika Hokusai.
- Yayoi Kusama.

↳ Sculpture
⇓

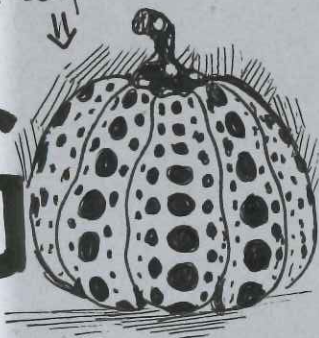

← Wanting to try different styles from all around the world.

↓
Wanting to embrace the diversity of artistic styles.

Art is to make objects "UNFAMILIAR"!

↳ To make forms difficult.

↳ To increase the difficulty and length of PERCEPTION.

"Art is thinking in images."

"Everything you can imagine is REAL!!"

"Creativity takes COURAGE!"

ING FORMS

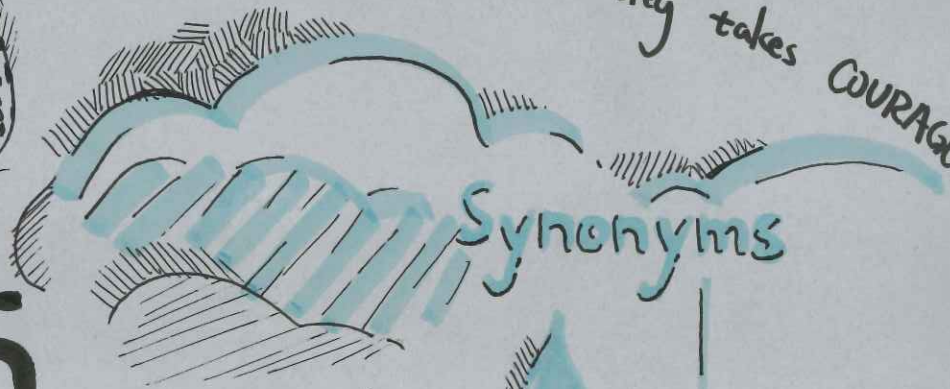

Synonyms



⇒ Combining two or more shapes together.

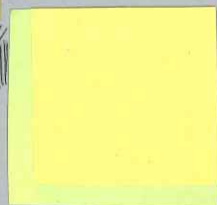
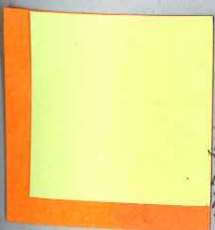
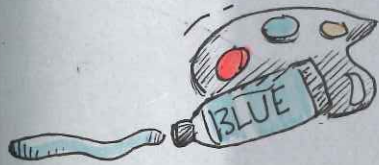

- ① Card models.
- ② Ceramics.
- ③ Wires.

- ④ Drawing
 - ↳ painting
 - ↳ Doodles
 - ↳ Sketches.

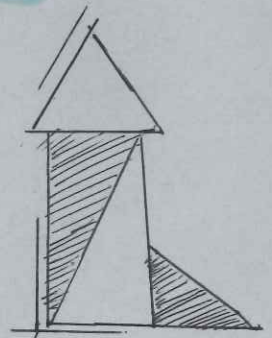

FRANZ

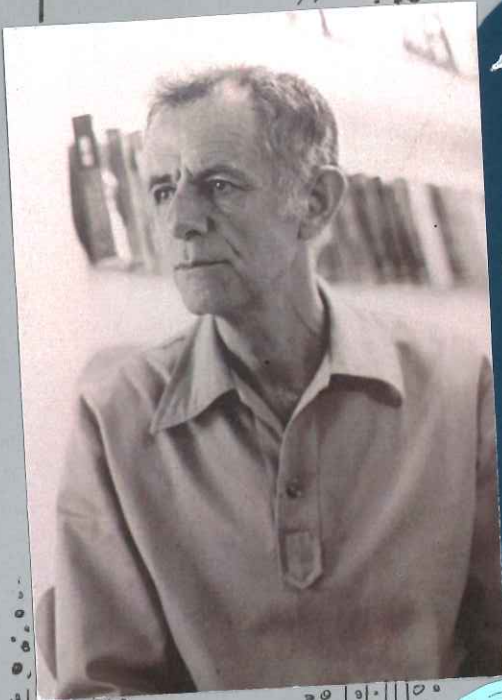

Franz Josef Weissmann was a Brazilian sculptor born in Australia. (1911)
Geometric shapes e.g. cubes, squares, are STRONGLY featured in his works.
He was one of the founders of the Neo-Concrete Movement.

I find cool colors calm and elegant, so I chose navy blue to begin with. I took inspiration from Weissmann and decided to use combinations of triangular shapes. I think Weissmann's shapes look balanced and equal → to the point.

I referred to Weissmann's work since I find the way he bends and arrange his shapes really interesting.

The colours of his shapes are plain and brief, which makes the whole artwork feel clean and tidy, and even satisfying.

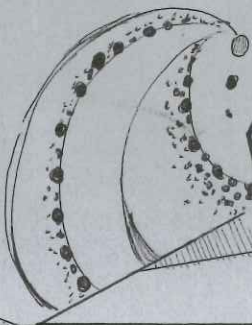
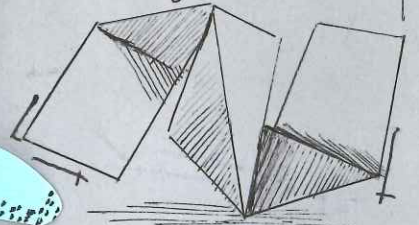
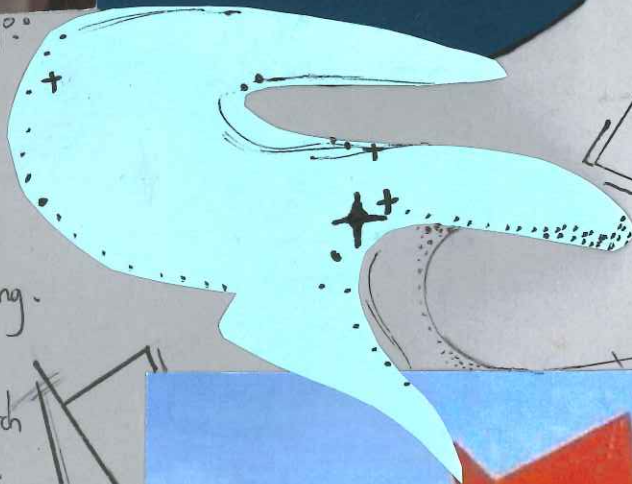

WEISSMANN

Franz Weissmann became the master of an entire generation in the 1940s as 50s, influencing the works and thought of artists like Mary Vieira and Amílcar de Castro.



Franz Weissmann was interested in seeing his creations on sidewalks and public squares. He used materials such as wires, rebar, bars, tubes, angles and metal plates.

He started to elaborate abstract and geometric sculptures after 1950.

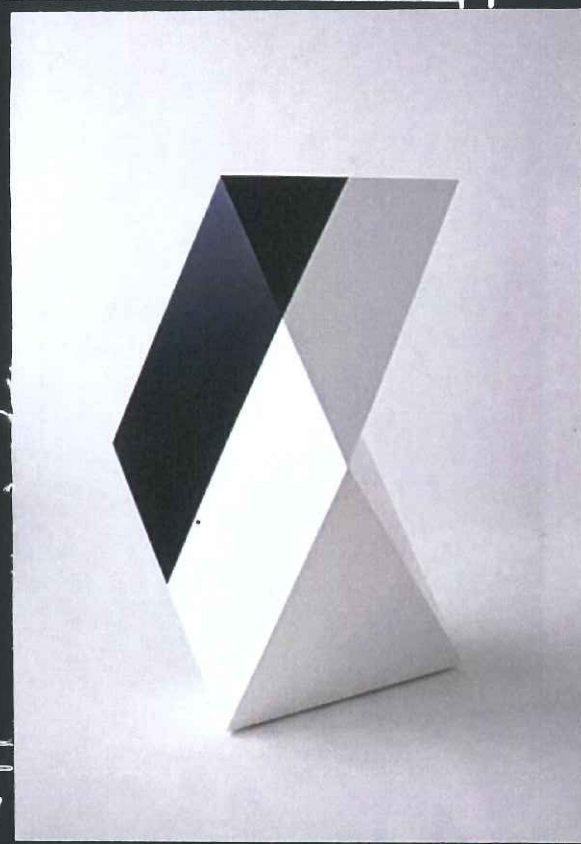
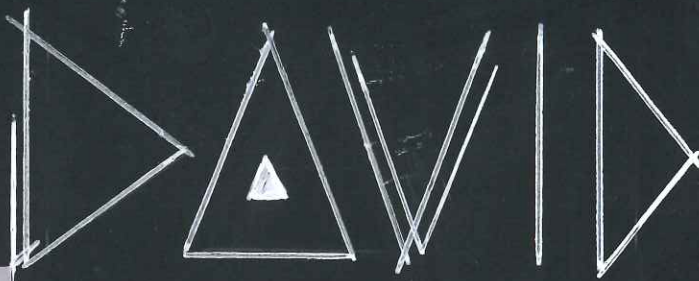

David Bill was born in 1976 and he is seen as an established mid-career contemporary artist, who originates from Switzerland. He likes to use black and white to create equality and contrast, also to make shapes look more 3-dimensional.



↙ combination of triangles

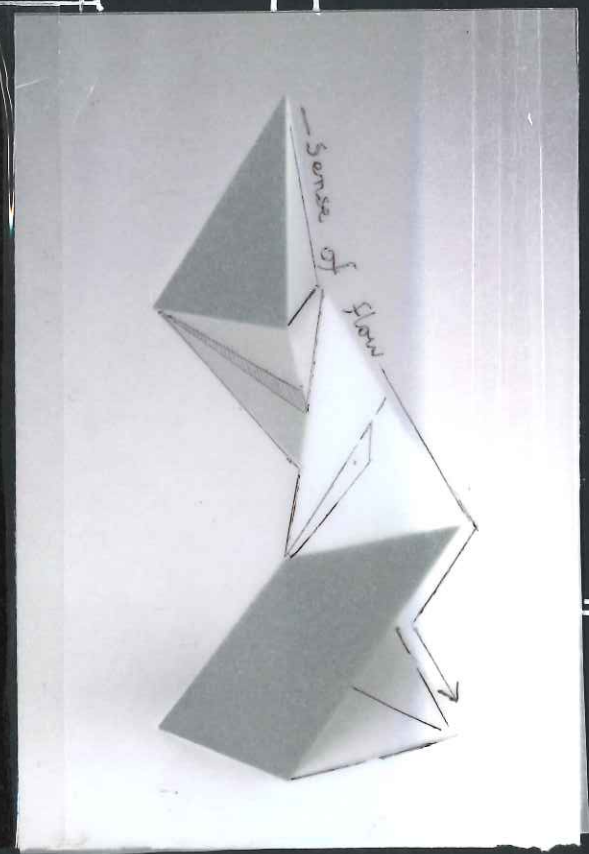
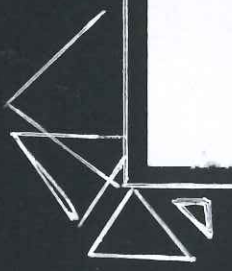
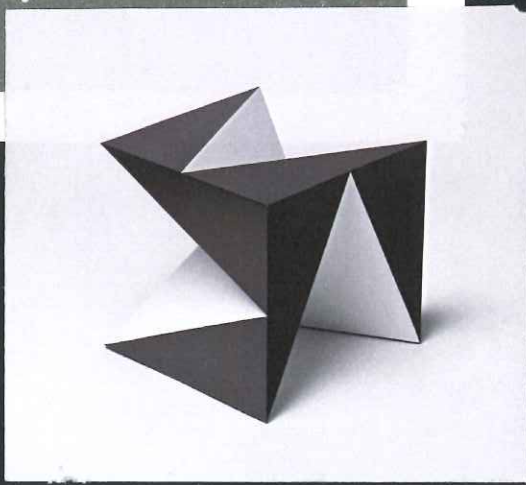

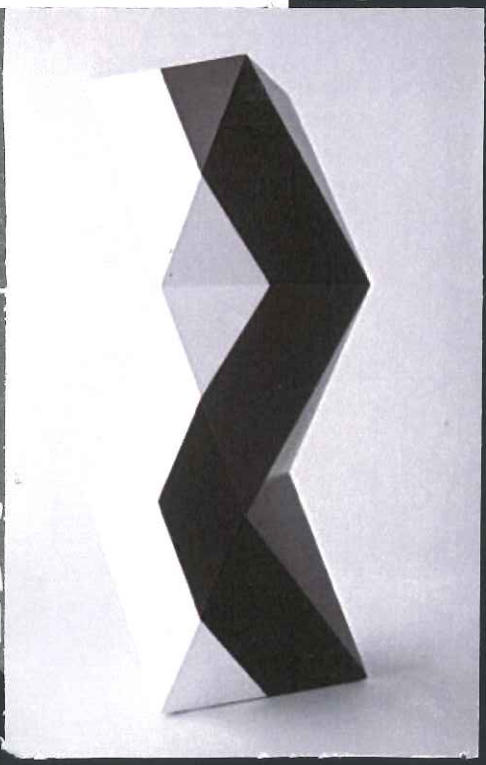
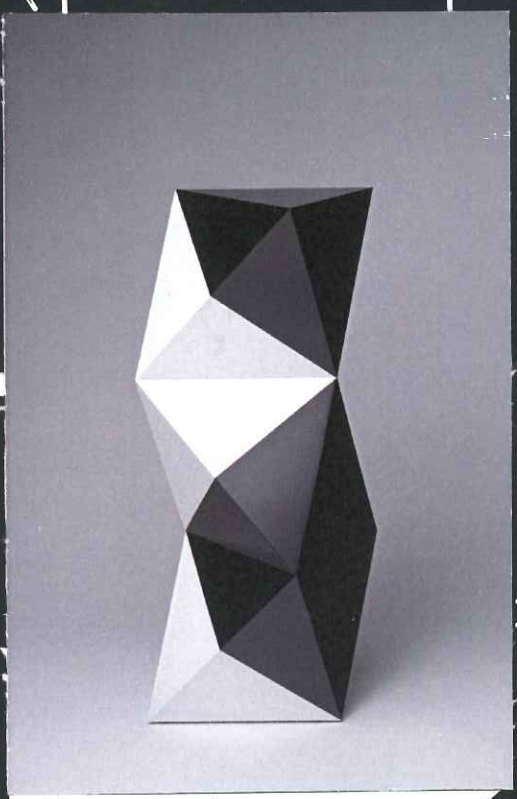
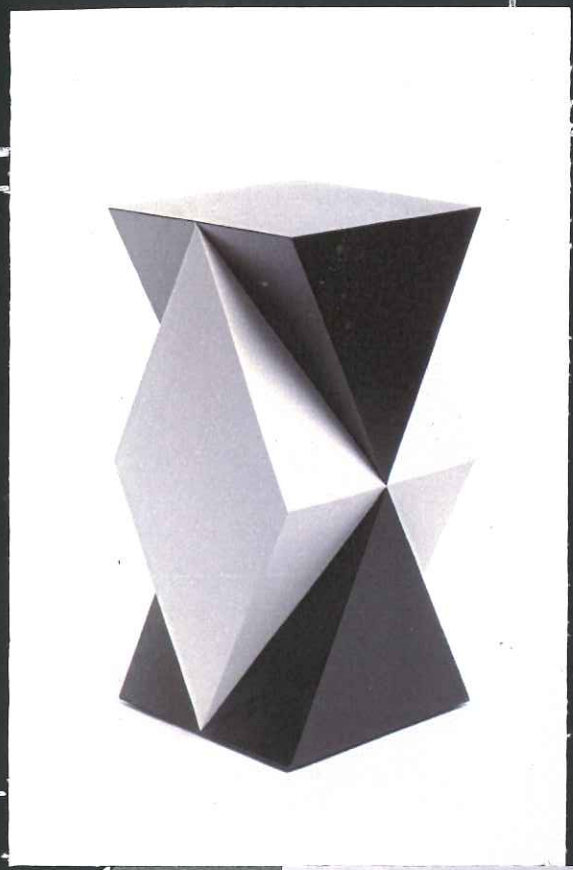
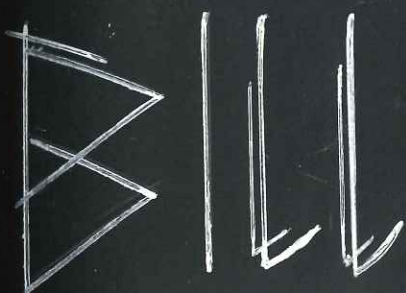

I really like his simple style and the structures and combinations of his shapes. I referred to his works and tried to make my works simple and tidy, also focusing on equality and steepness of shapes -

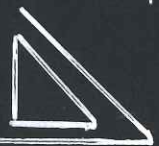

INITIAL

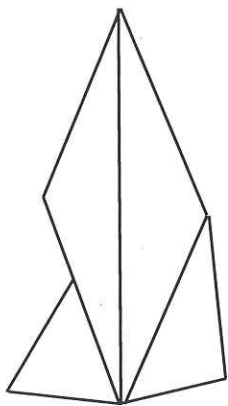
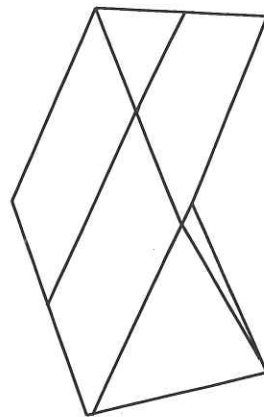
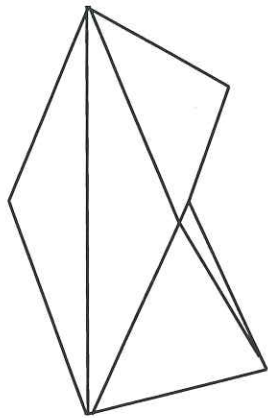

I referred to Weismann and Bill's works and tried to create some designs based on their style. I tried to combine various shapes together to make the final shape look three dimensional and creative. The works from both of the artists inspired me, so I made my shapes look concave and convex. I rearranged my shapes into different forms, trying to find a balanced position.

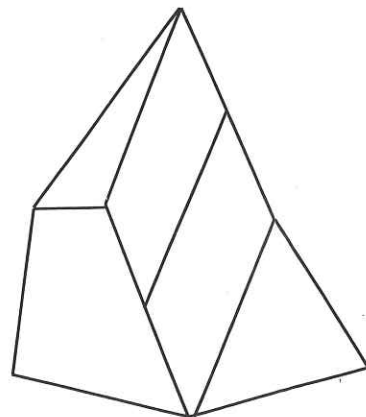
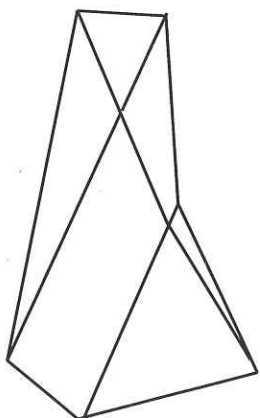

DESIGN !

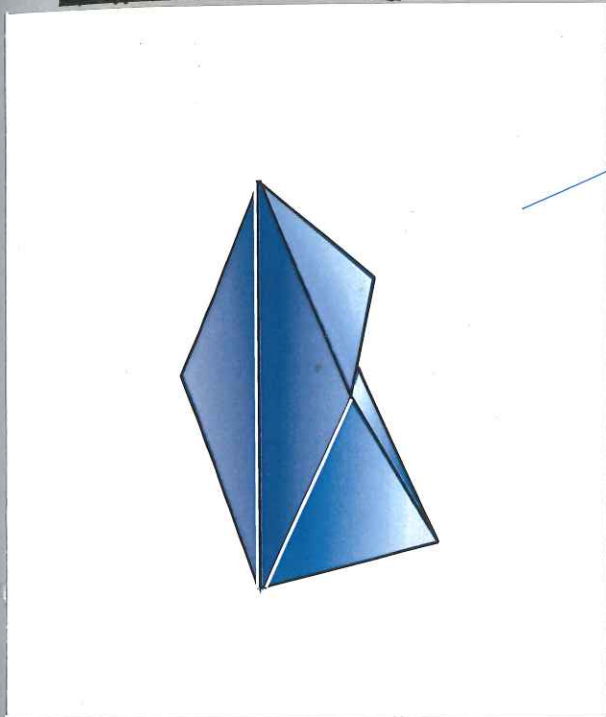

→ I really tried to focus on equality and steepness of my shape, so I made the triangles in different sizes and lengths, and arranged them to look more balanced.

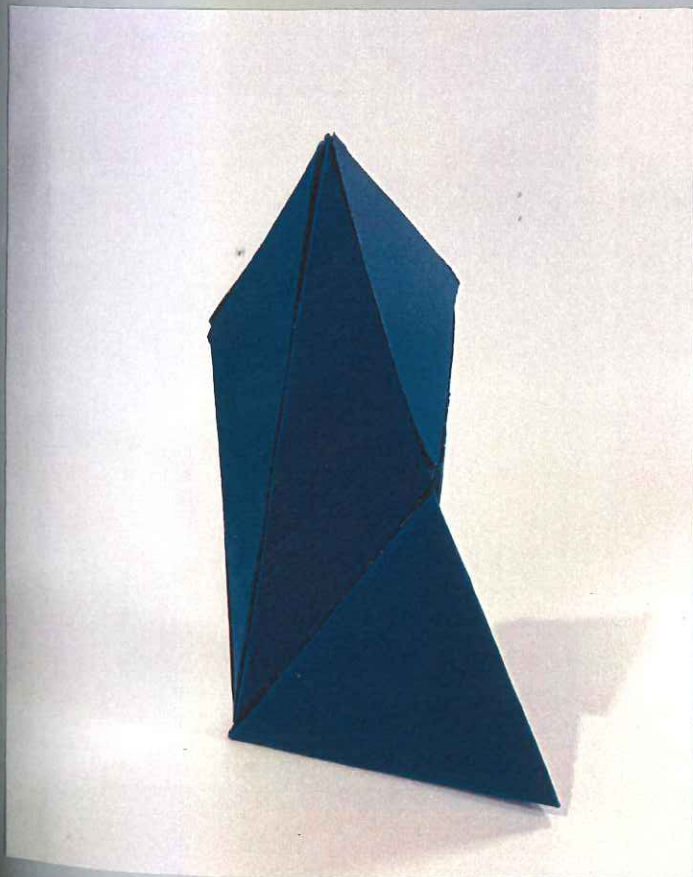

Both artists ~~used~~ uses simple colours for their shapes, and I find it very organized and neat. I chose to use navy blue to fill my shapes in, since it looks calm and elegant.

BACK ↓

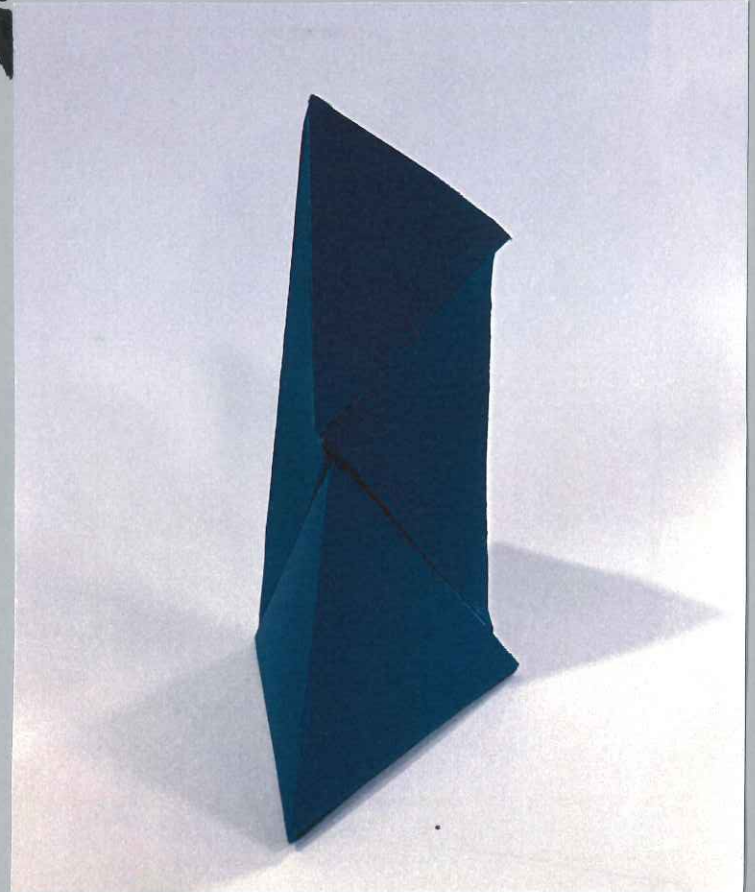

Eventually, I used cardmodel to display my final design. I think cardmodel can show the depth, details and the colour the best, so I made a few triangles and combined them together. Therefore, the final model looks three dimensional and organized.

FRONT ↓

I also really enjoyed to see the cardmodel under different light sources. The shadow and the depth of the shape varies, which made it look more interesting and attractive.

KANDIN



Wassily
Wassilyevich
Kandinsky
was a painter
and theorist.

Born in Moscow,
spent his
childhood in
Odessa, Russia.

One of the
pioneers of
abstraction in
Western art.

↳ "I remember that drawing
and a little bit later painting
lifted me out of the reality,"
he wrote later.

His
visiting of
an exhibition of
the French impressionists
and the Bolshoi Theatre
affected him to give up his
successful career of being a
Professor to the Department
of Law.



Kandinsky due to his active creativity and organizational skills always attracted anything intellectual, restless, striving, which was in the world of art of that time.

KANDINSKY

I find Kandinsky's combination of colours in his artworks really interesting and amusing. I also like the lines and shapes, which creates a



vivid and lively feeling, also appearing to be thoughtful and meaningful. ←

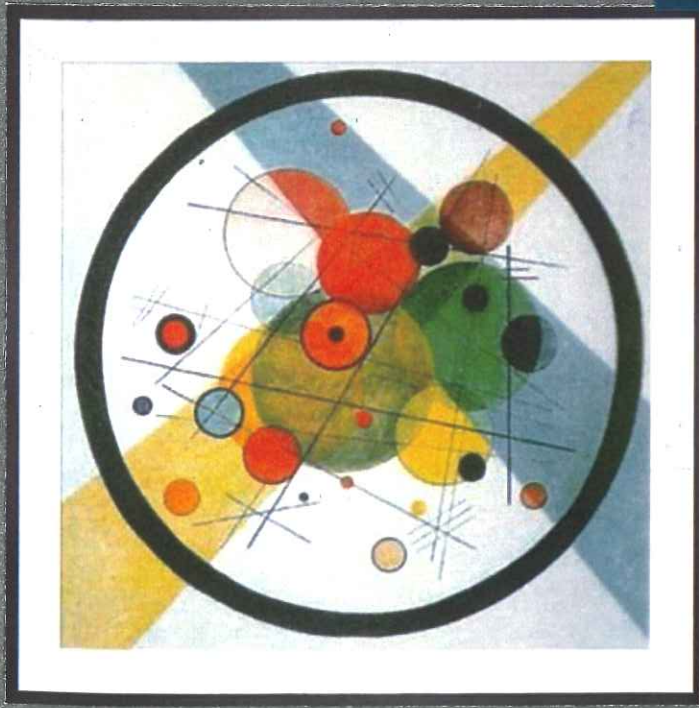
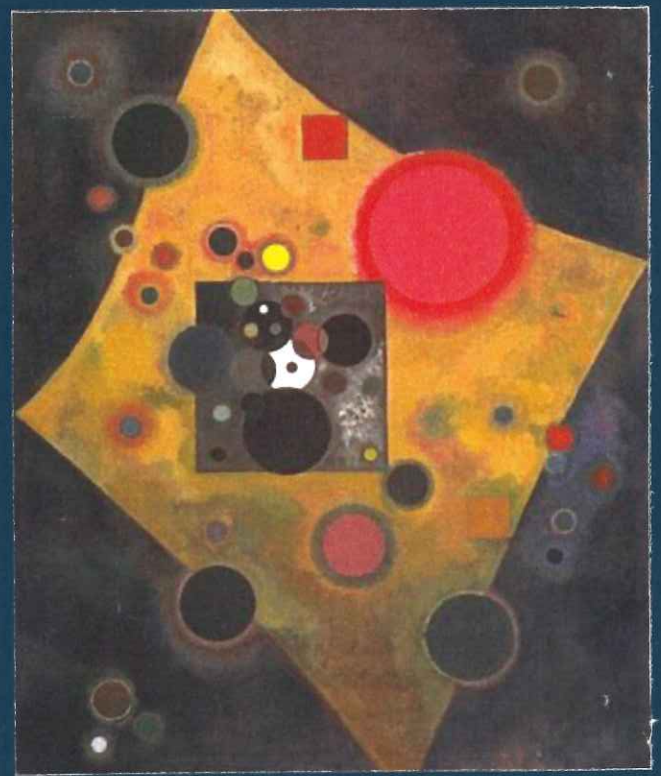

I want to refer to his artworks and use his ideas of colours and shapes for my own design, (which makes my shapes more attractive and unique).

↳ In 1911 Kandinsky together with his friends, Wassily Kandinsky, an artist, established a group called Blue Rider (Blauer Reiter).



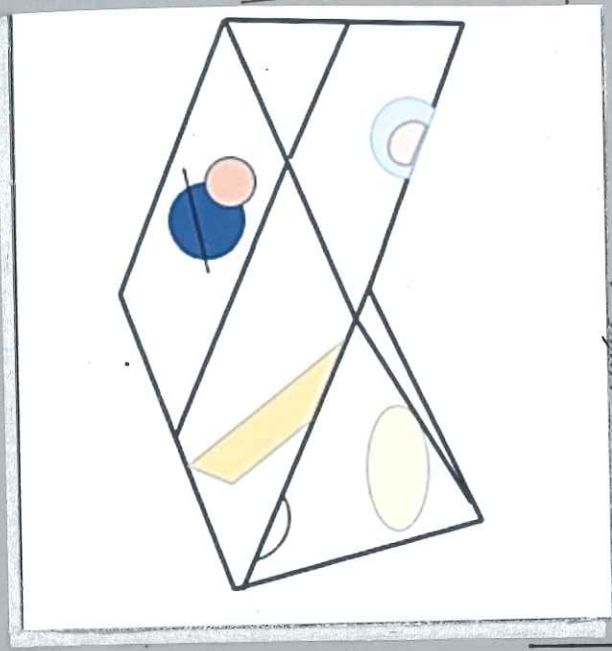
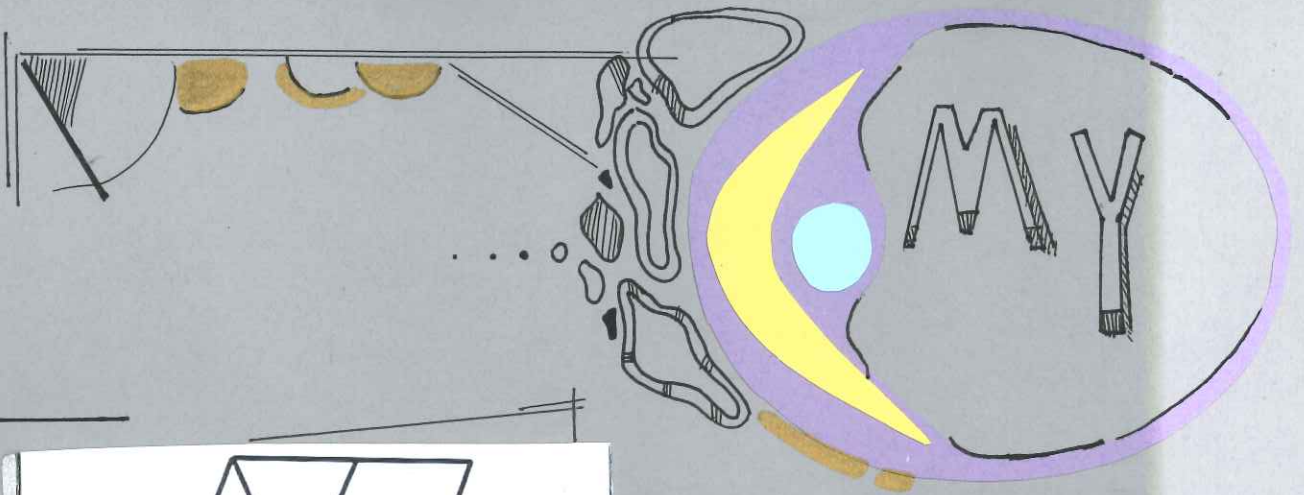

I referred to Kandinsky's works, and added some shapes on my designs. I focused on positioning the shapes, making everything look balanced and thoughtful.

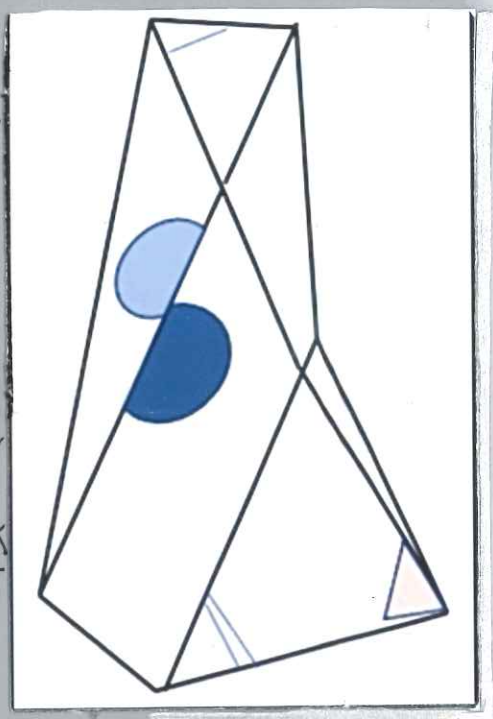

I find Kandinsky's color schemes fairly interesting. Even most of colours are bright and contrasted, but they still matches well with each other.

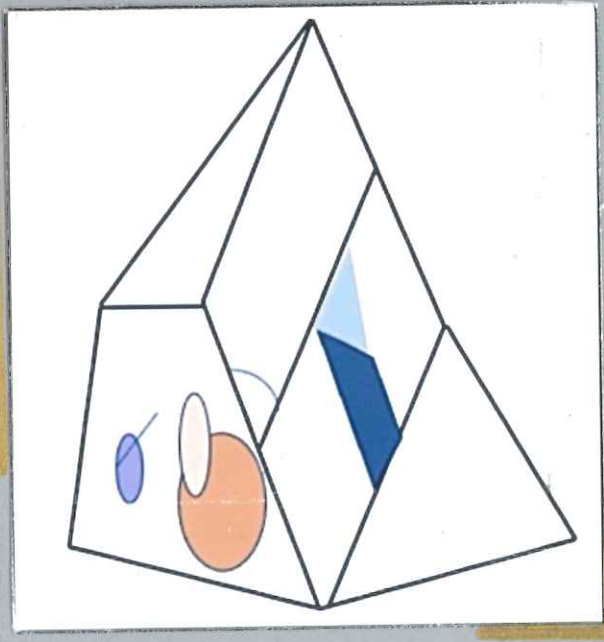

I really like pastel colors, so I ~~try~~ tried to match orange/yellowish colors with blue and cooler colors. Pastel colors creates a cozy, dreamy and sweet atmosphere. I also tried to use many circles and semicircles, which can soften the edges and angles of the shapes.

INITIAL DESIGNS

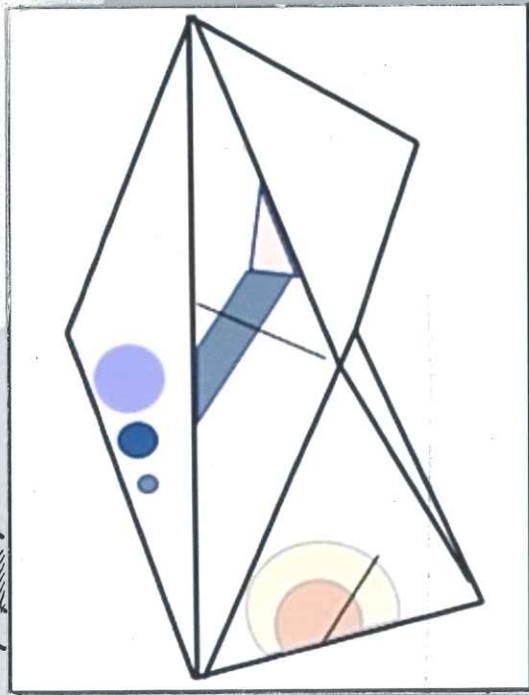

I also tried not to make my designs look overcomplex and messy.

Therefore, I tried to spread out the shapes, so everything looks neat and tidy.

In many Kandinsky's works, he also put lines through different shapes and also around them.

↳ Therefore, I also put few lines on my designs, which surprisingly made my designs look amusing and interesting.

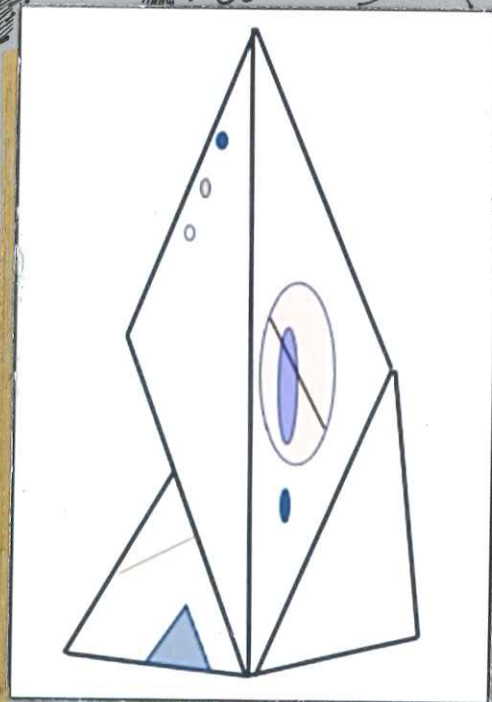

FINISH

I chose some coloured paper and cut them into varies of shapes, and stuck them in different positions, according to my initial design.

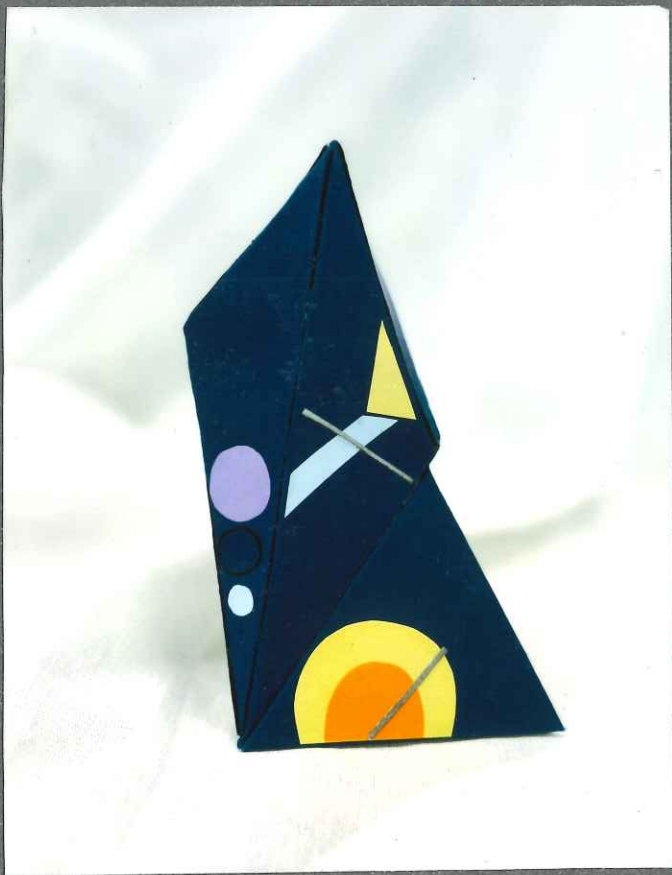

ORANGE + YELLOW + BLUE + GREY

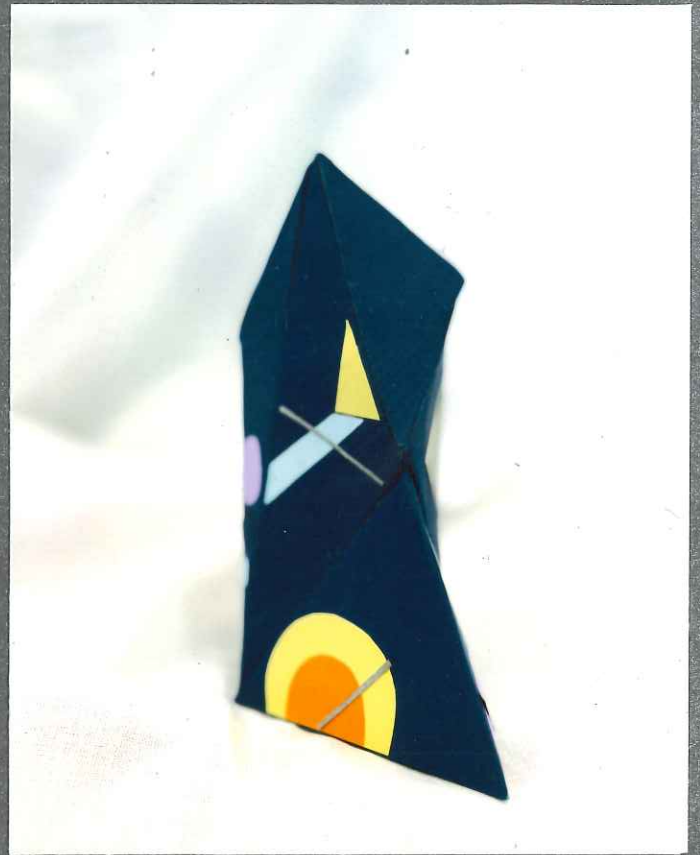

I also tried to design the different faces of the shape, adding more shapes and trying to balance the colours, making the model look more abundant and attractive.

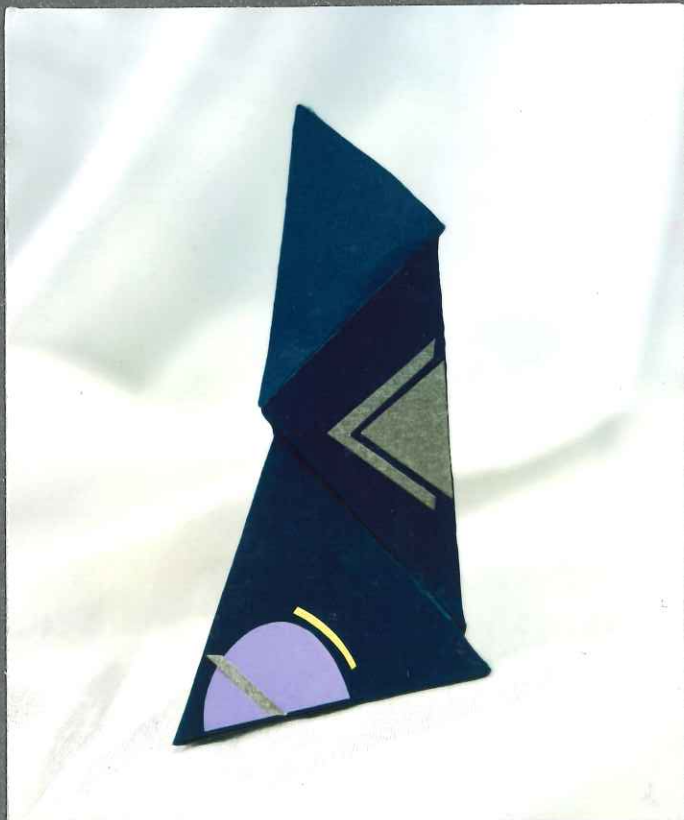

← PURPLE + YELLOW + GREY

ED

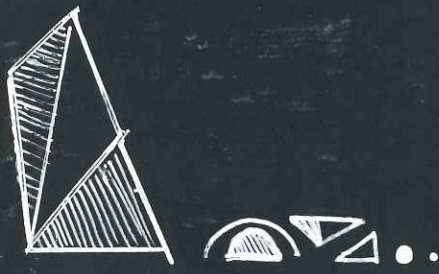

SCULPTURAL MODEL

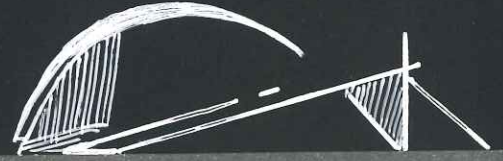

I chose navy blue for my model → to make the shapes and design stand out and create a dynamic feeling, making my sculpture more vivid and thoughtful.

I used circles and triangles to create contrast, while circles seems to be soft and round / triangles are sharp and stiff. Therefore, the sculpture looks more balanced and interesting.

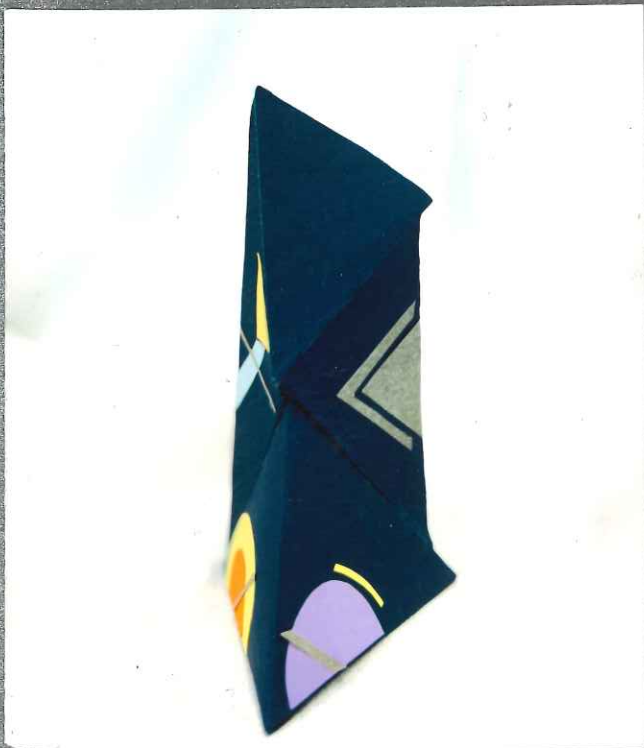

My sculpture is made up of several triangles, so the triangular decorations correspond to the overall shape, and the circles also softens the sharp edges and makes the overall sculpture more smooth and flexible.

I also added some lines to enrich my decorations, which adds novelty to my sculpture.

Evaluation



1. IDEA 

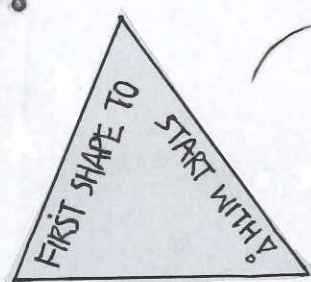

2. Combining multiple triangles together

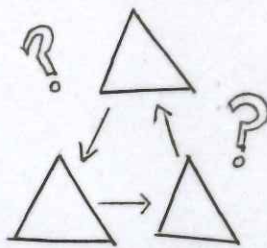

3. Chose the best DESIGN!

4. Decorated the design.

Firstly, I was inspired by Franz Weissmann and Paul Bill, wanting to explore the theme of minimalism.

Therefore, I started to create different designs by combining a variety of shapes.

It was really entertaining and inspiring, when I transferred my thoughts into lines and shapes, and I enjoyed the process of arranging the lines, and I would feel a sense of accomplishment once the line goes to the perfect position, and the outline of the shape starts to appear.

I think I should also consider other orientations for my design, so that it is easier for me to make into a solid model, and I have a better idea and concept of it.

I then filled my design with one, main color (blue), and worked on gradations of light and shade, so my design becomes three-dimensional.

PRACTICAL WORK!! : I took some navy blue card paper and started sketching, measuring and cutting out the shapes. After that, I stuck them together with double-sided tape. It was the first time for me to make the card model very officially, therefore, it came out looking quite rough. So I think next time I should focus on the corners and edges so my model look more smooth. Eventually, I was inspired by Kandinsky and started to decorate my ^{model} design with lots of different shapes, so it looks more finished and attractive.

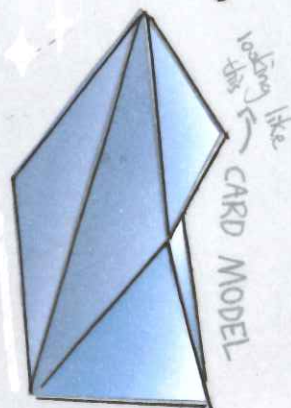
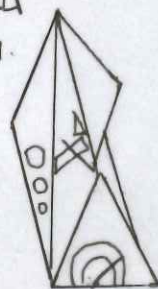

Further Design.

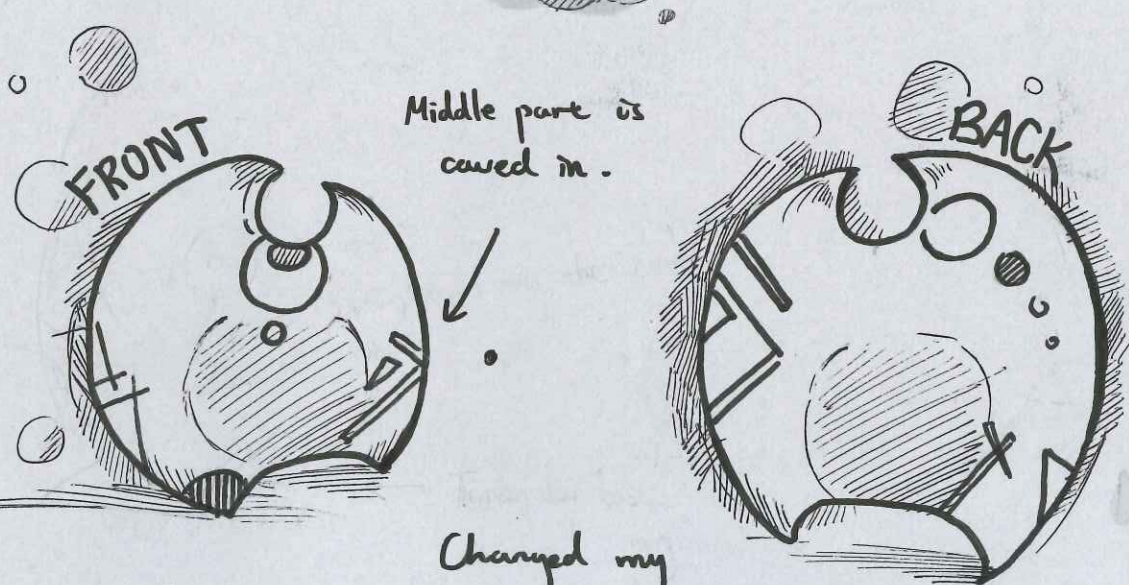

Middle part is caved in.

Decorations layoune
↓

|| △ ○ ○ ○
Lines / Triangles / Circles

Changed my shape from triangle
→ circle.

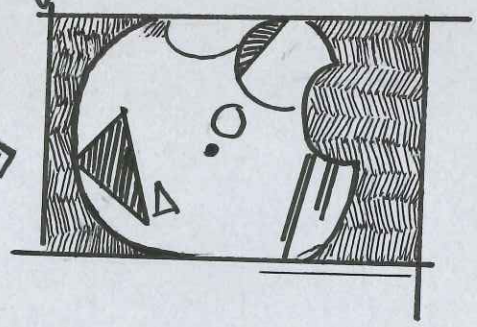

Revised design
↓

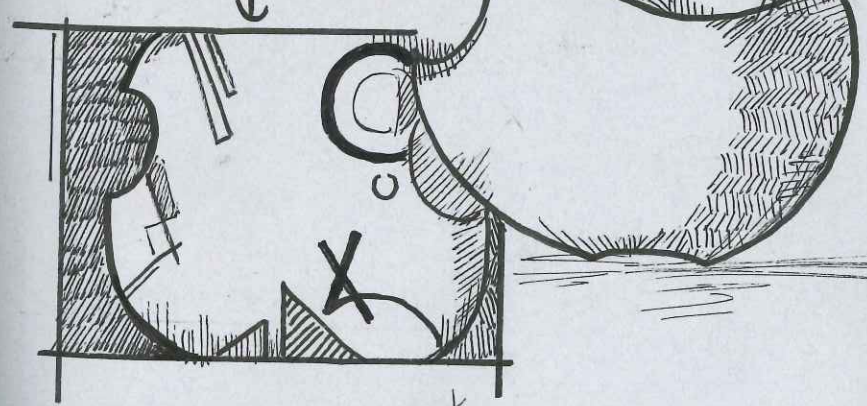

Smaller circle on a bigger circle
←



Evaluation

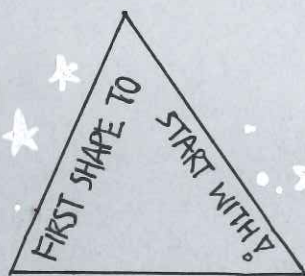

Firstly, I was inspired by **Franz Weissmann** and **David Bell**, wanting to explore the theme of minimalism.

Therefore, I started to create different designs by combining a variety of shapes.

It was really entertaining and inspiring, when I transferred my thoughts into lines and shapes. I enjoyed the process of arranging the lines, and I would feel a sense of accomplishment once the line goes to the perfect position, and the outline of the shape starts to appear. I think I should also consider other orientations for my design, so that it is easier for me to make into a solid model, and I have a better idea and concept of it.

I then filled my design with one, main color (blue), and worked on gradations of light and shade, so my design becomes three-dimensional.

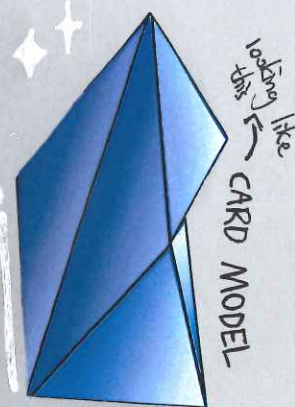

PRACTICAL WORK!! : I took some navy blue card paper and started sketching, measuring and cutting out the shapes. After that, I stuck them together with double-sided tape. It was the first time for me to make the card model ~~very~~ officially, therefore, it came out looking quite rough. So I think next time I should focus on the corners and edges, so my model look more smooth. Eventually, I was inspired by **Kandinsky** and started to decorate my ~~design~~ ^{model} with lots of different shapes, so it looks more finished and attractive.

Further Design

FRONT

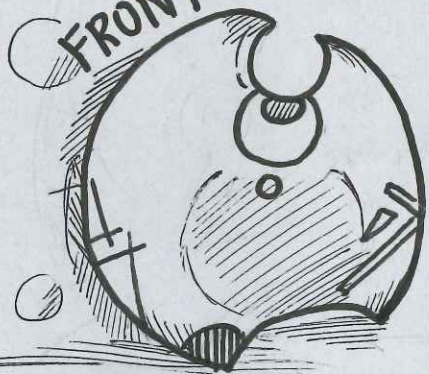

Middle part is caved in.



BACK

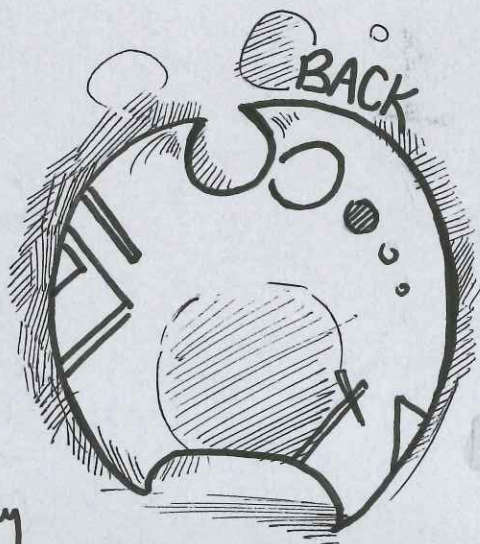

Decorations layout



Lines / Triangles / Circles

Changed my shape from triangle → circle.

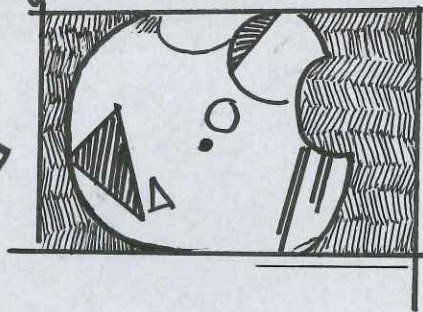

Detailed design

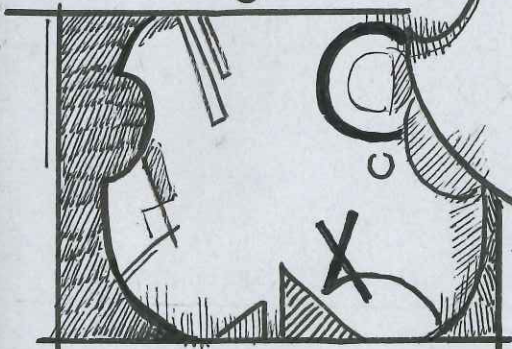

Smaller circle on a bigger circle



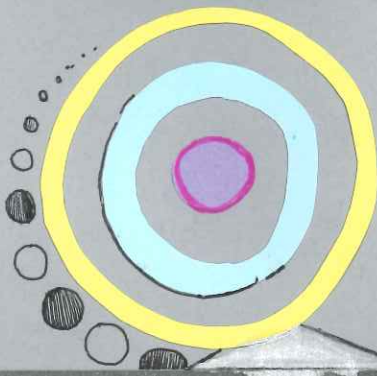

-Vasa Mithich is a renowned Los Angeles-based artist known for his sleek, colorful and captivating acrylic sculptures.

He is a Senior Professor of Design at the University of California, Los Angeles (UCLA) where he has taught color theory for many years.

For nearly 30 years he has been working in acrylics, whether on canvas or through sculpture.

His sculptures, with their different geometric planes suspended in acrylic, are dynamic and endlessly fascinating.

The minimalist sculpture is a paradigm of Mithich's ongoing investigations of light, color, and negative space.

These key optical characteristics are present throughout his oeuvre.

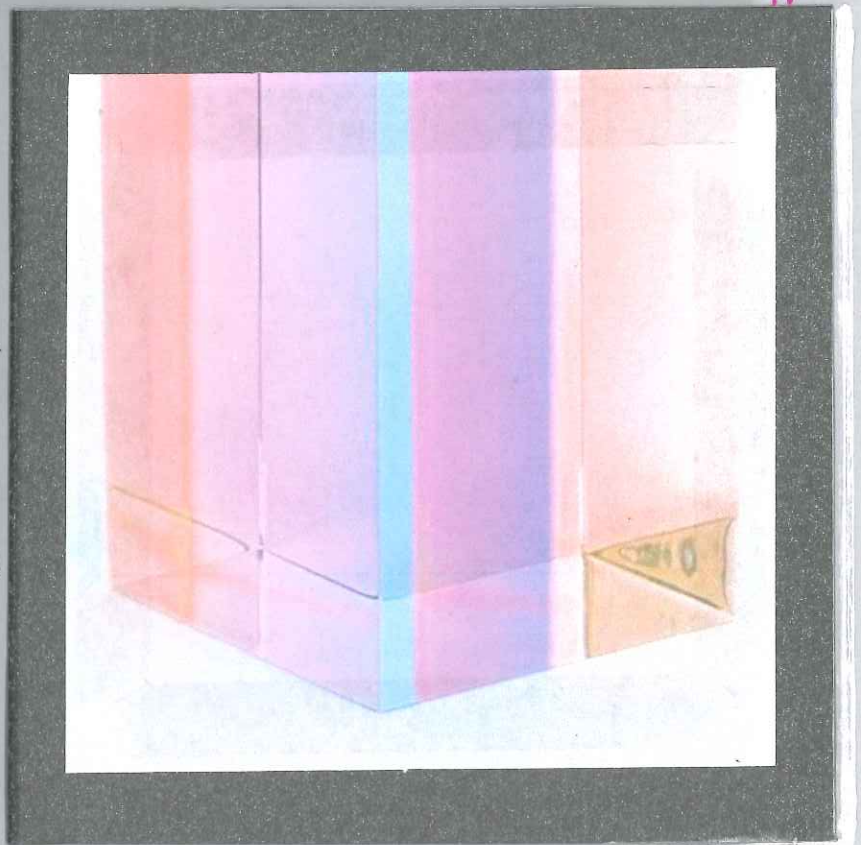

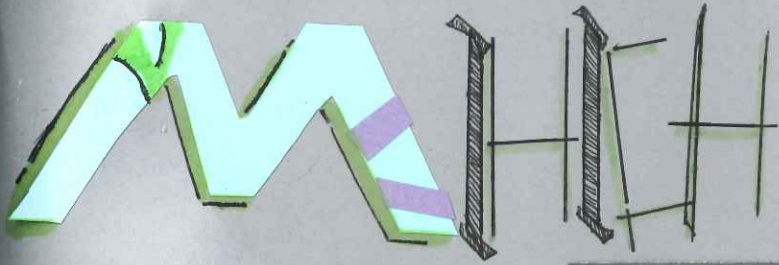

He began working with transparent and colored plastics in the late '60s while living in Los Angeles, and has since acquired the machinery and technology necessary to create his signature minimalist acrylic sculptures, which reflect and refract light.

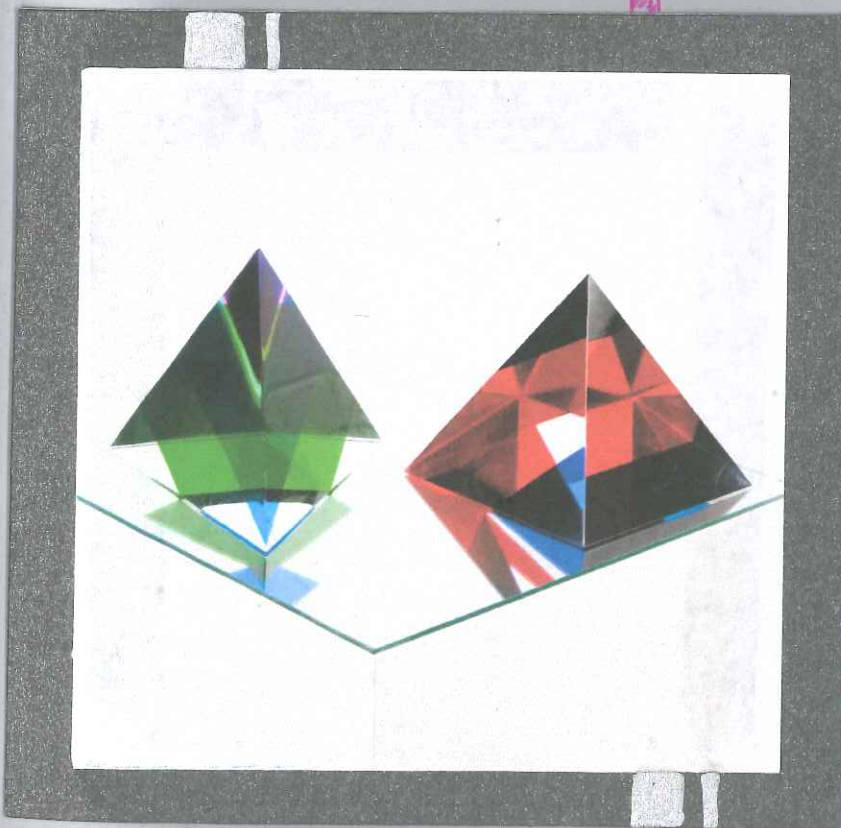

I find the colors he use very thoughtful and matches ~~me~~ together very well. I really like the sense of transparency and how the light works with the sculpture.

I like how the light is refracted, and how it separate and split the color into small pieces, — appearing to be like diamonds.

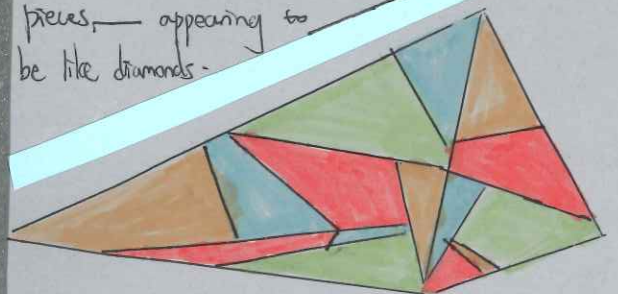

MY TESTING MODELS

↳ I referred to Franz Weissmann's sculptures and made some testing models. I tried to use the material which is about the same thickness of the acrylic sheet.

Therefore, I used the paperboard and cut a few triangles out, so I can stick them together and combine them in different ways.

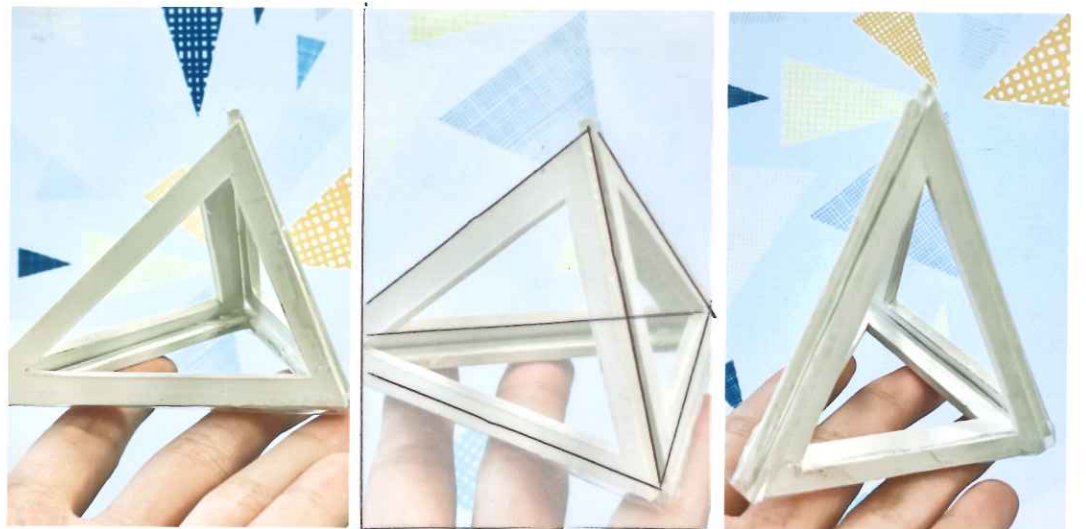

1.

2. I made a few more triangles and developed my original model.

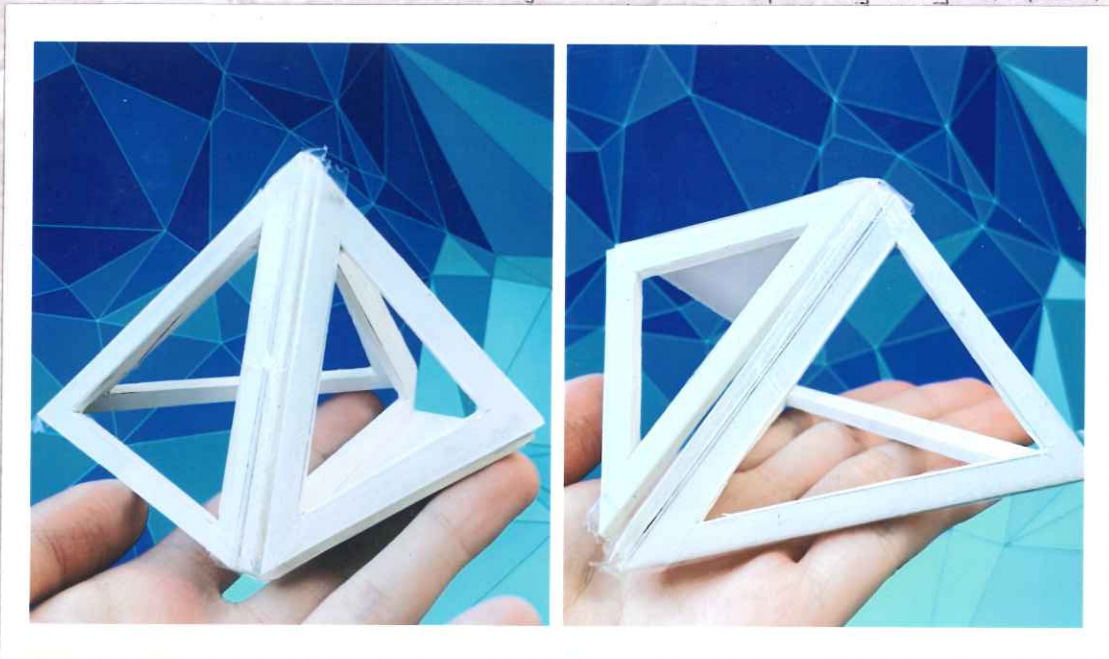

Developed ◻ ◻ ◻

→ I tried to carve out the inside of the triangles to make them hollow. Therefore, I improved my skill for cutting out triangles.

Eventually, I cut out some more triangles and brought everything together.

I also used the inside parts of the triangles that I've cut out and made my sculpture more complex.

3. Final Testing Model →

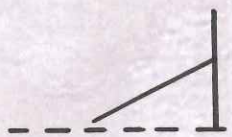
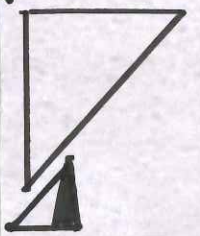
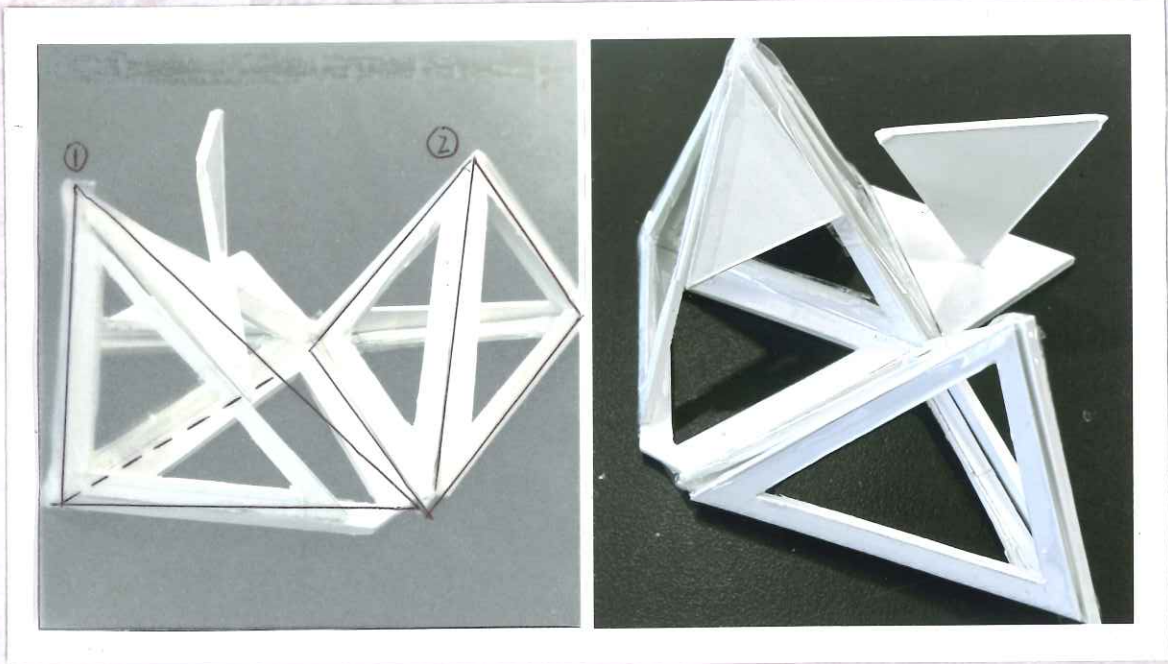
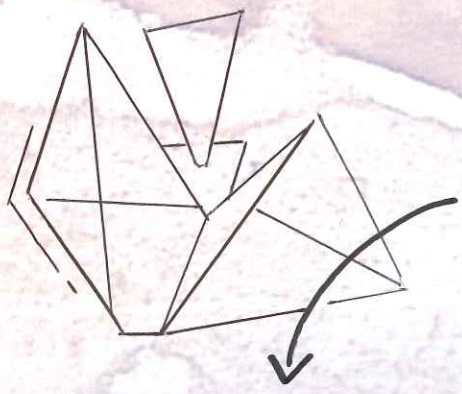
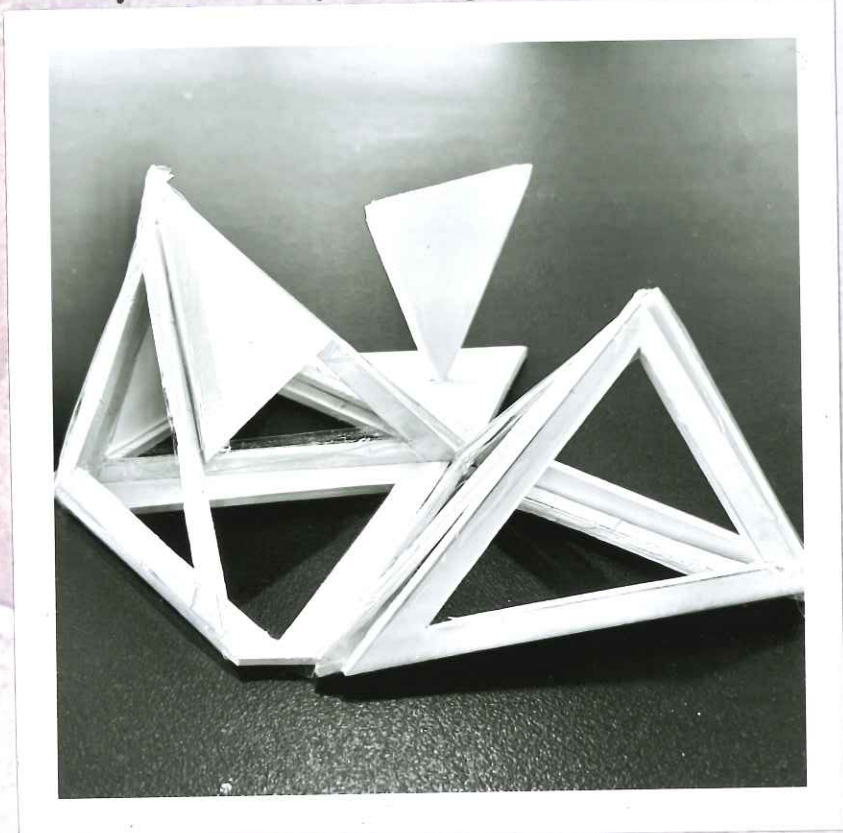

* Constructed mainly with two triangles.

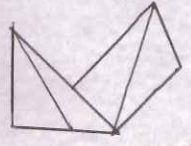



◊ ○ ○ ~ P A T T Z A T S ~ ∇

NATURE 0

FINAL

MODEL DESIGNS +

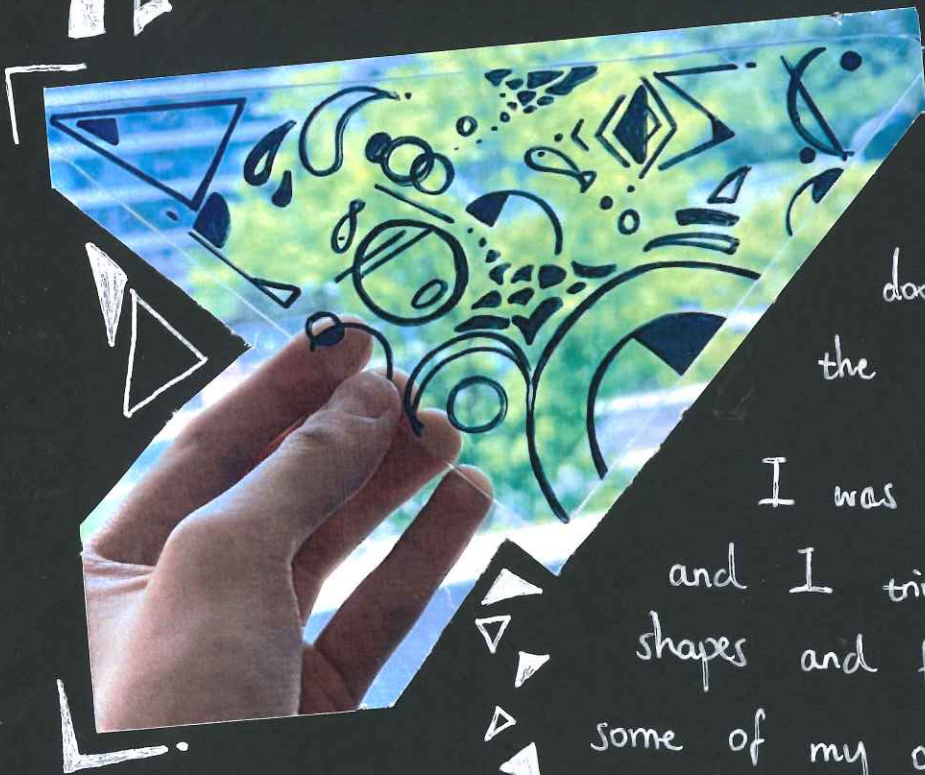

I used Sharpie and doodled on the surface of the acrylic sheet.

I was inspired by Kandinsky and I tried to play around with shapes and forms, also combining some of my own extended designs.

I then turned the acrylic sheet over and started to colour the shapes in, using acrylic paint.

I mainly used primary colours which brought vitality to the piece.

I chose to draw on different sides of the acrylic sheet, in order to make the piece look more layered and to give it an unique texture.



[FINAL MODEL]

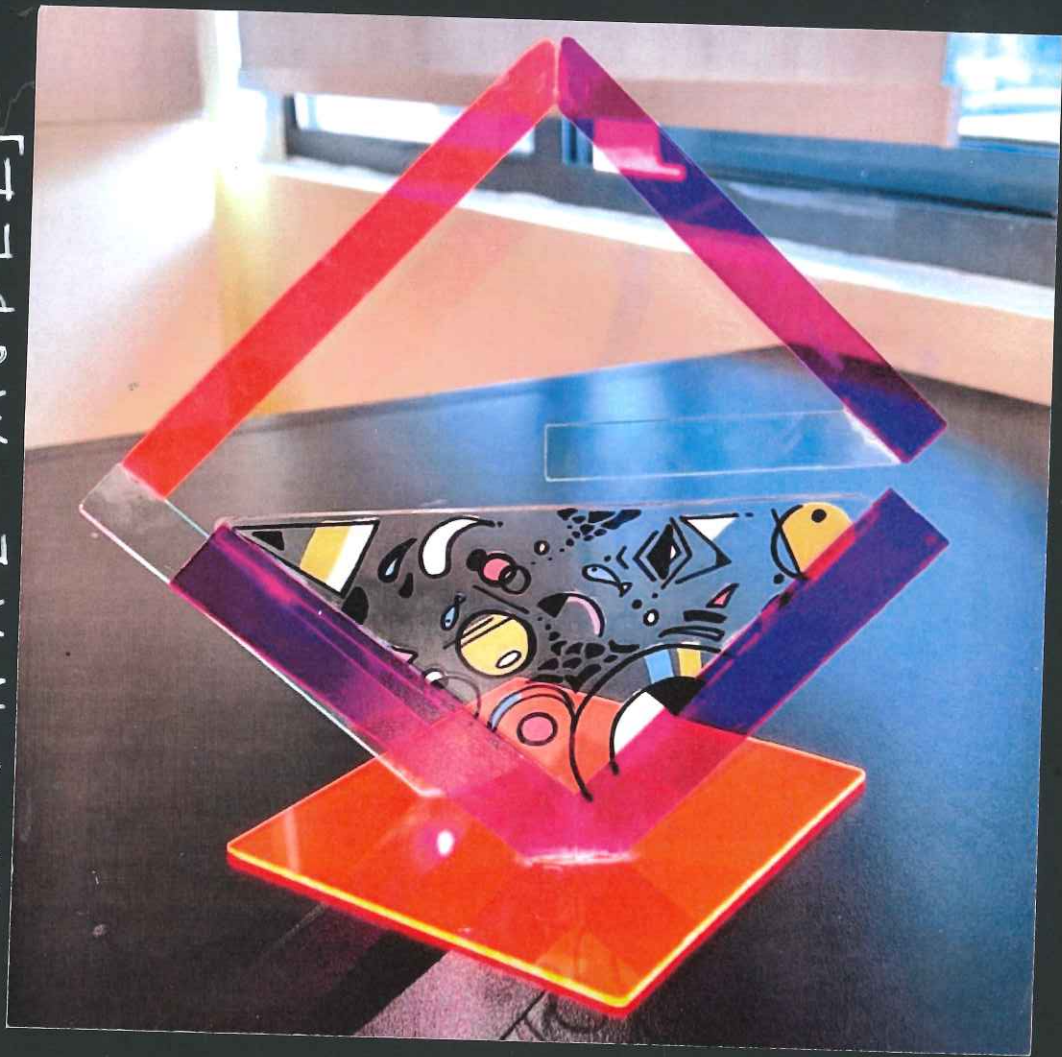

I was inspired by Weismann's work and designed a geometric frame. I cut ~~out~~ the acrylic into long strips and glued them together using super glue. I tried to make my model into ^{the shape of} a diamond, also focusing on the sense of space by giving the model a foreground and a background, in order to create visual impact.

 I was also inspired by Vasa Mihich to create an acrylic piece.

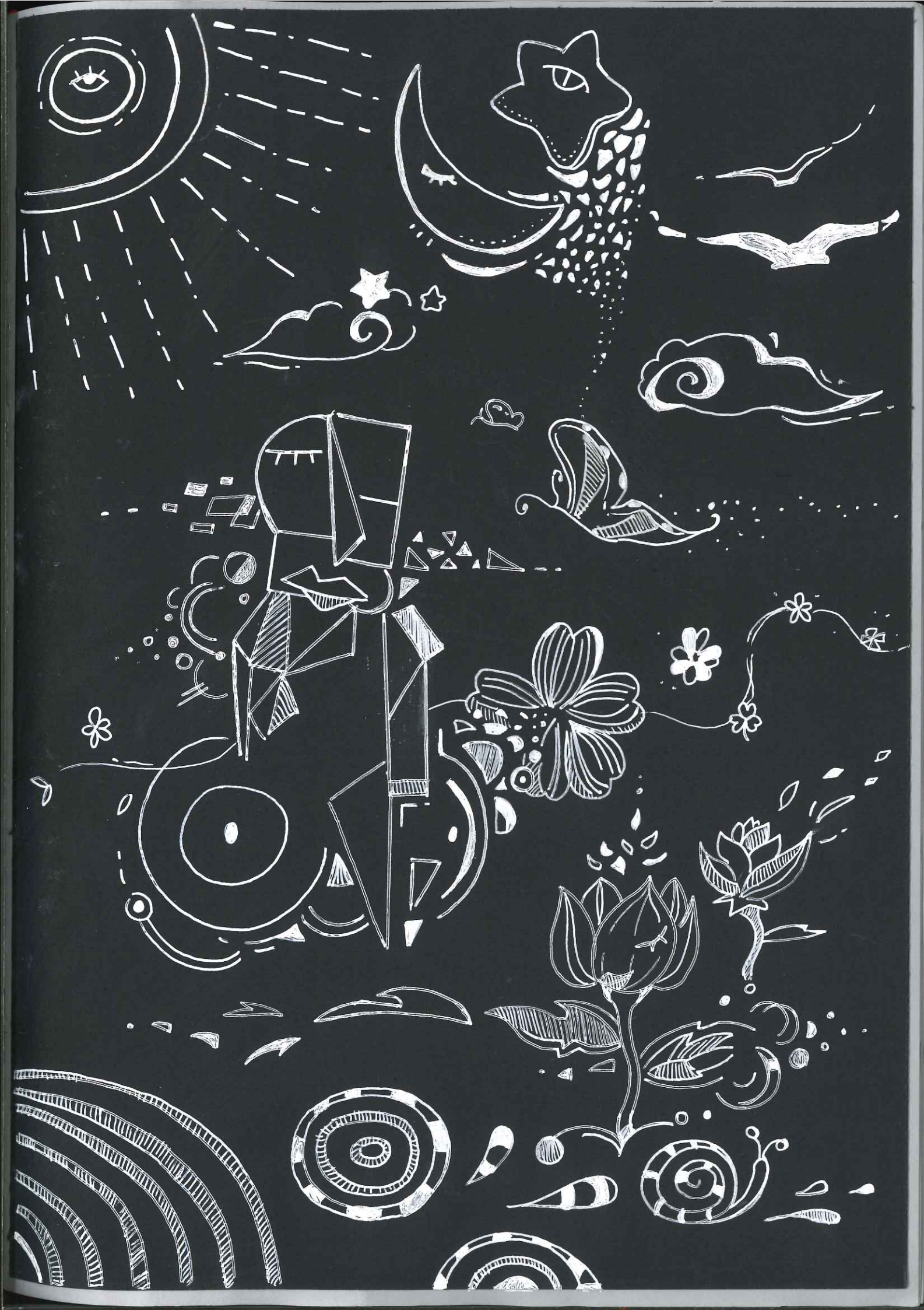

Final Piece

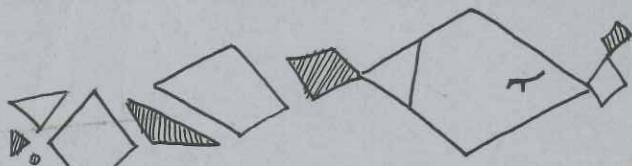

For my final sculpture, I will stick to the theme of marine organism, inspired by my previous works. This time, I'm going to focus on the sense of space and make the whole piece look more vivid and natural.

Another piece of acrylic using another colour.

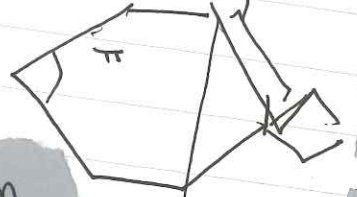

The fish goes through the frames on the sides which creates a 3D effect.

→ I also referred to Weismann's work, making the frame of my piece morphological.

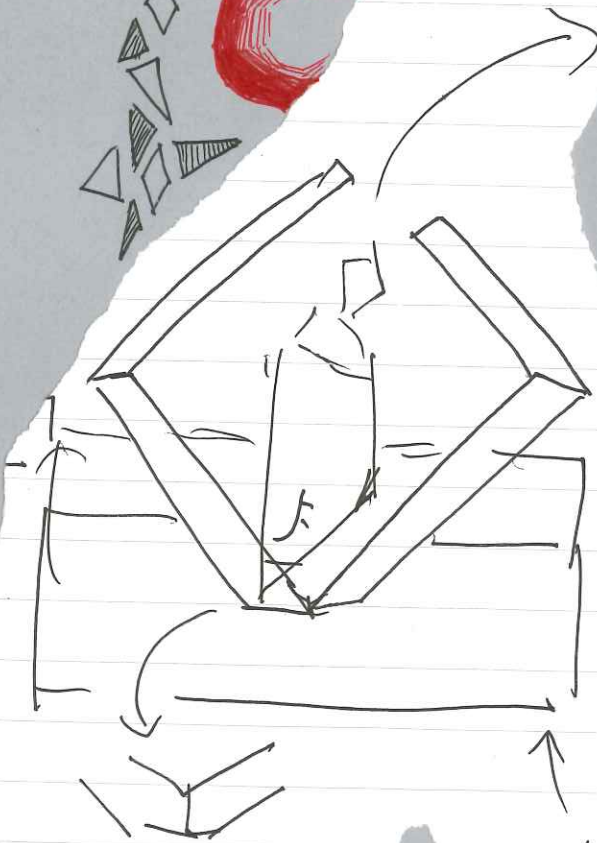

WEISSMANN



A huge base

Design ✨

I'm planning to doodle different patterns inspired by Kandinsky, on the acrylic sheet, and paint the shapes with acrylic paint on the other side of the acrylic sheet.
↳ Creates depth.

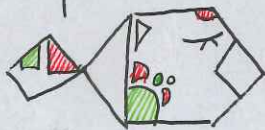

KANDINSKY ↗

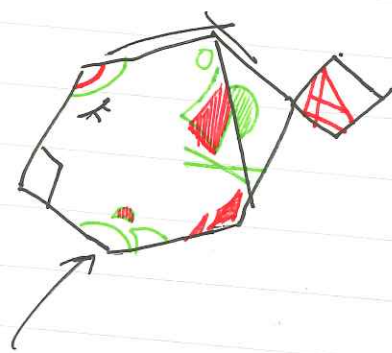

Acrylic paint +
Sharpie for the
patterns inspired by
Kandinsky.



DESIGN

I'm planning to include the idea of light and shadow to emphasize the wind dreaminess.

LIGHT



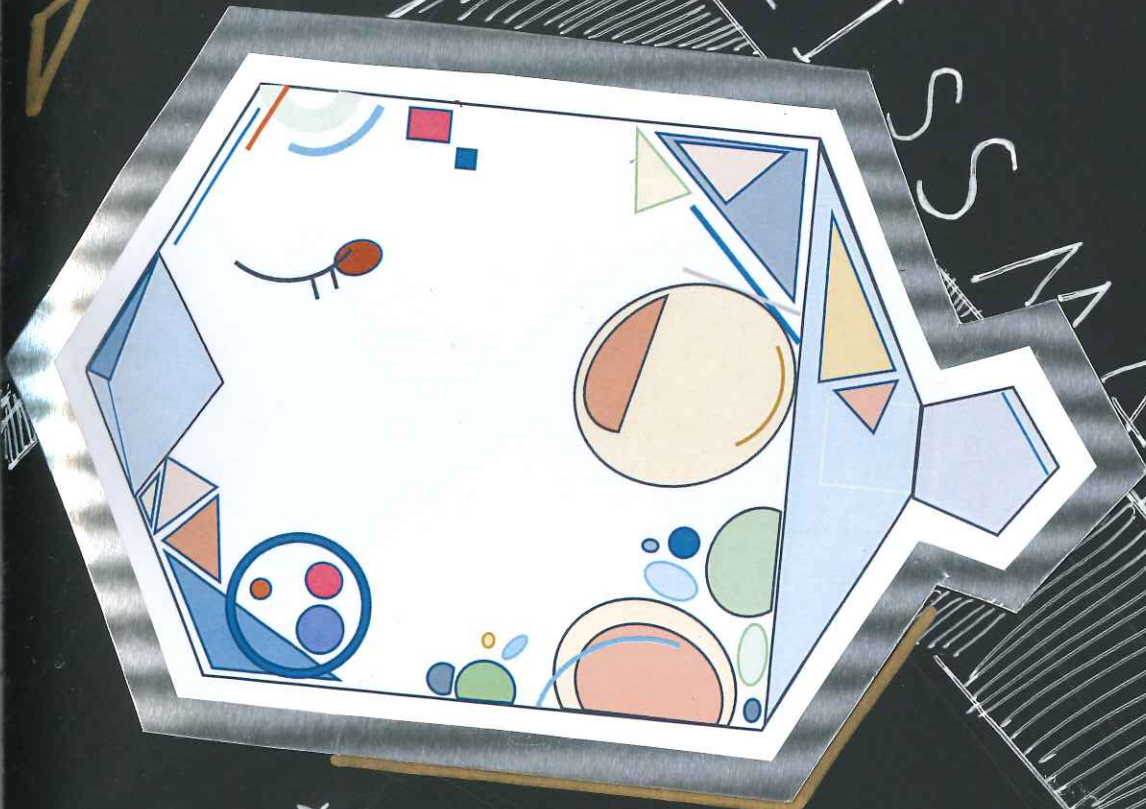

SSWV

SSWV

SSWV

SSWV

I think acrylic is a very suitable material for showing the synergy between light and shadow.



Forms +

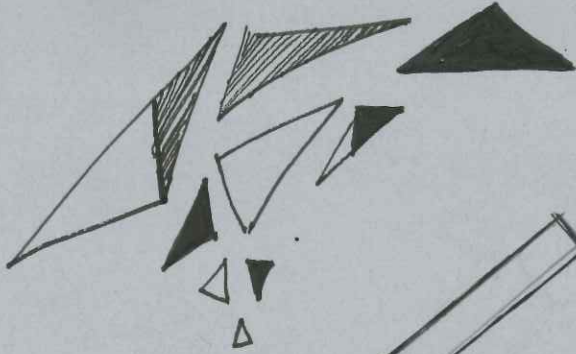

DESIGNS

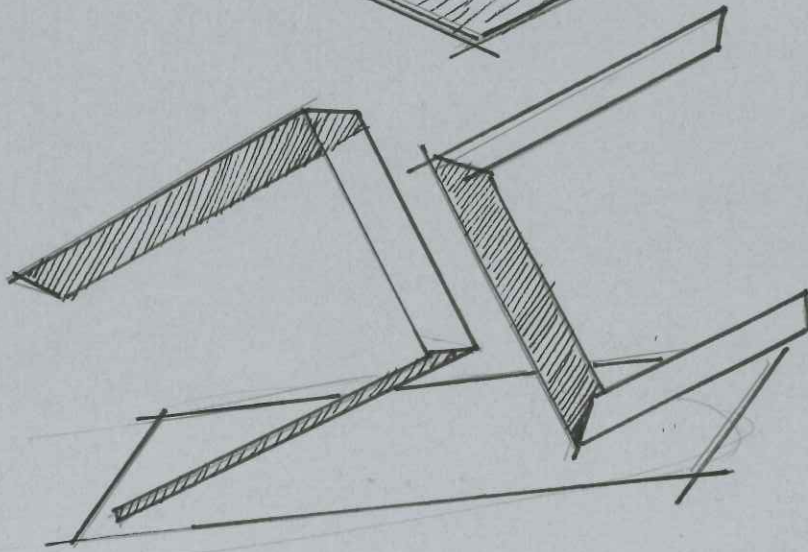
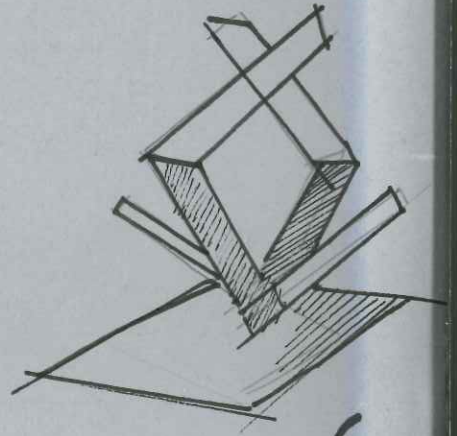
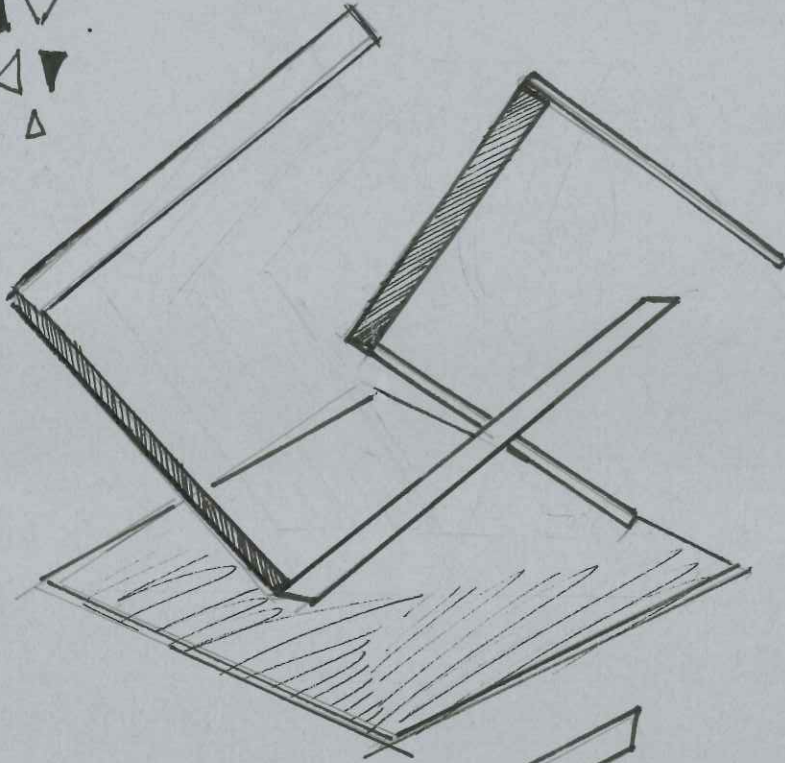

WELLS

Shapes

MANN

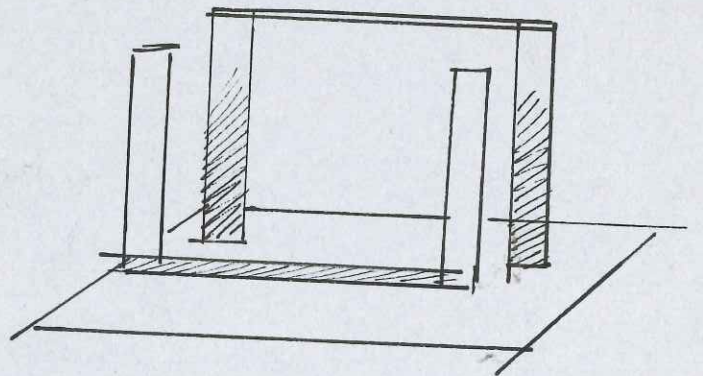
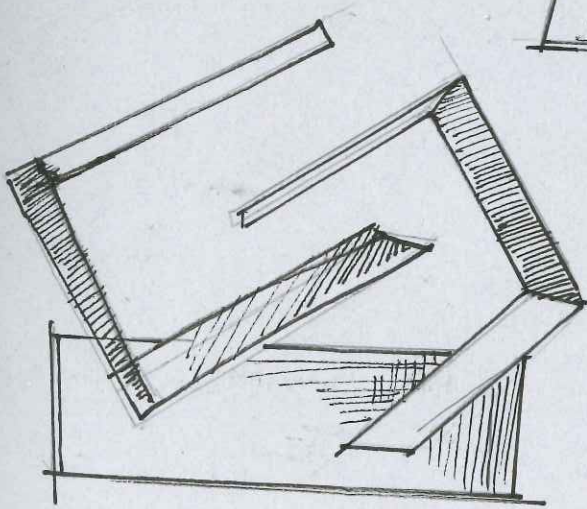
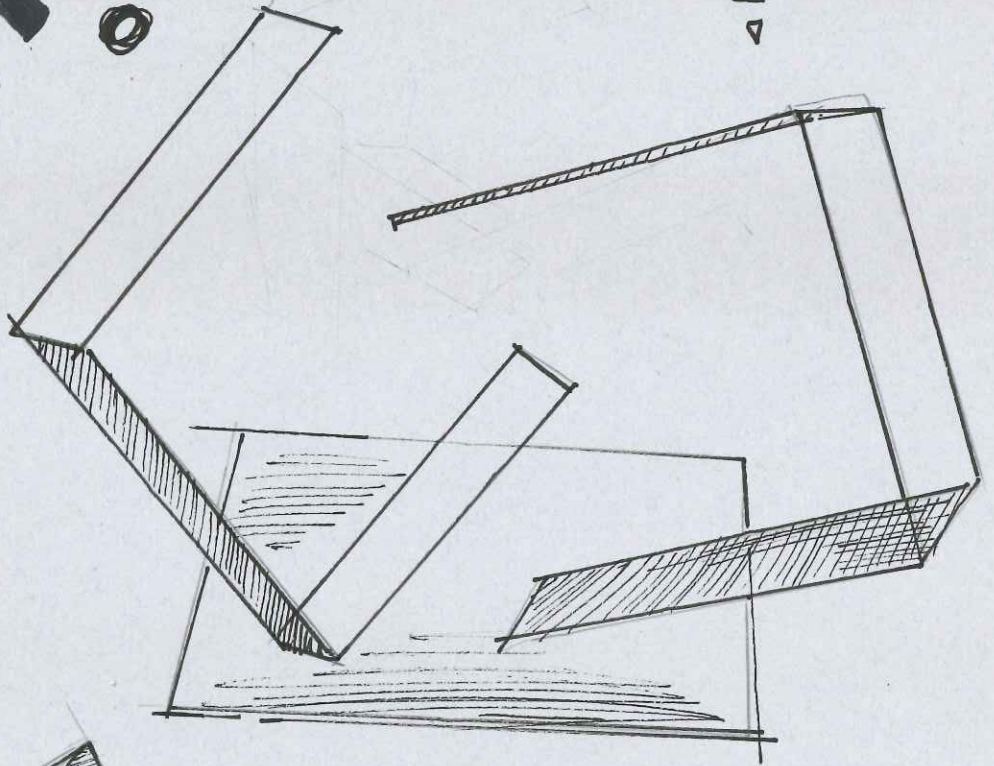
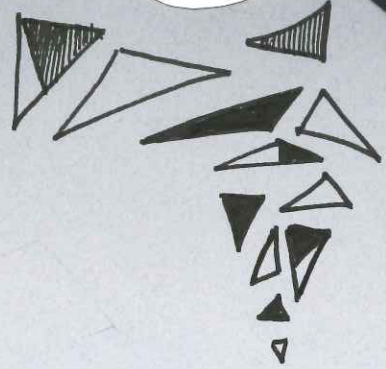

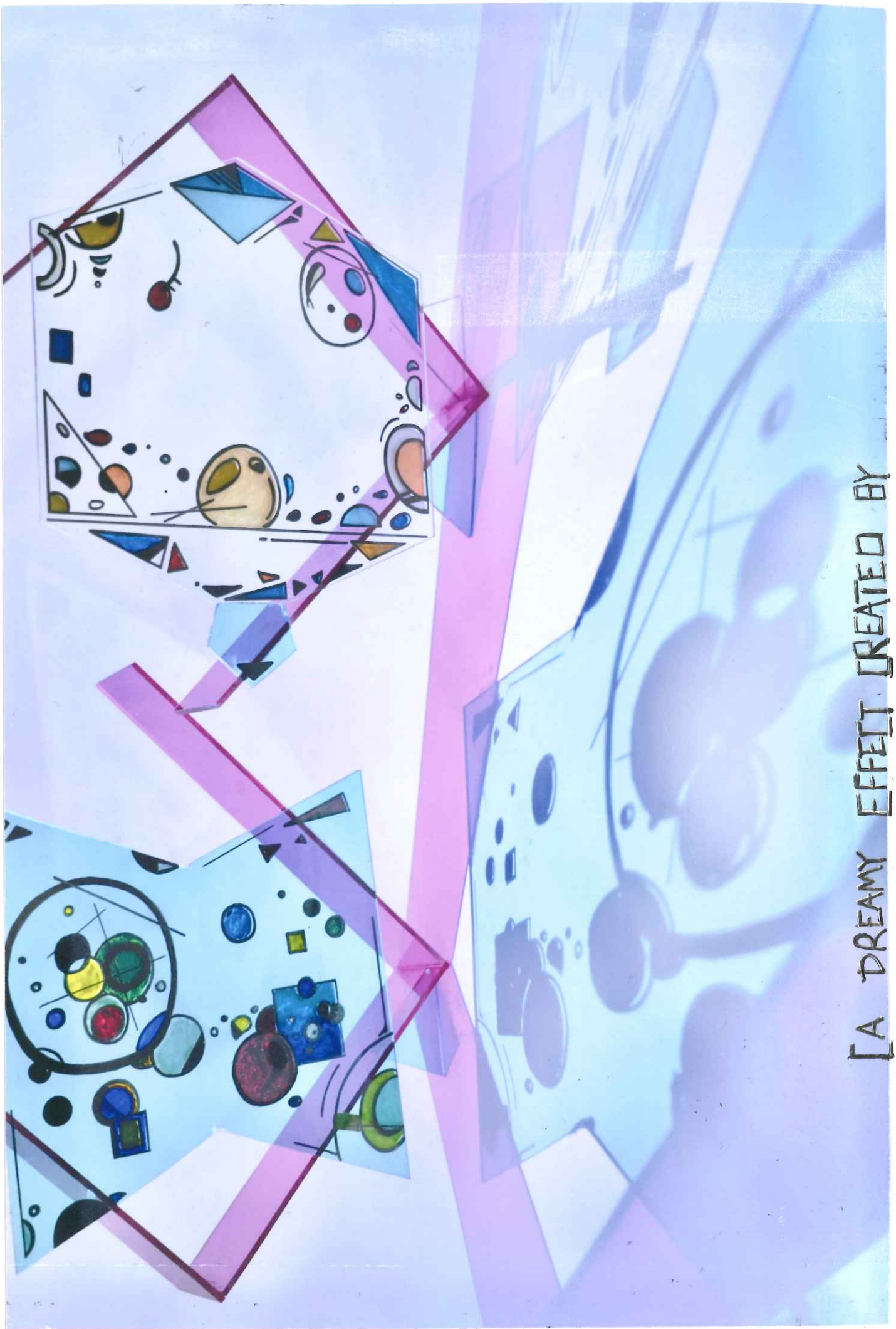

[A DREAMY EFFECT CREATED BY

「FINAL MODEL With Shadow」

LIGHT & SHADOW

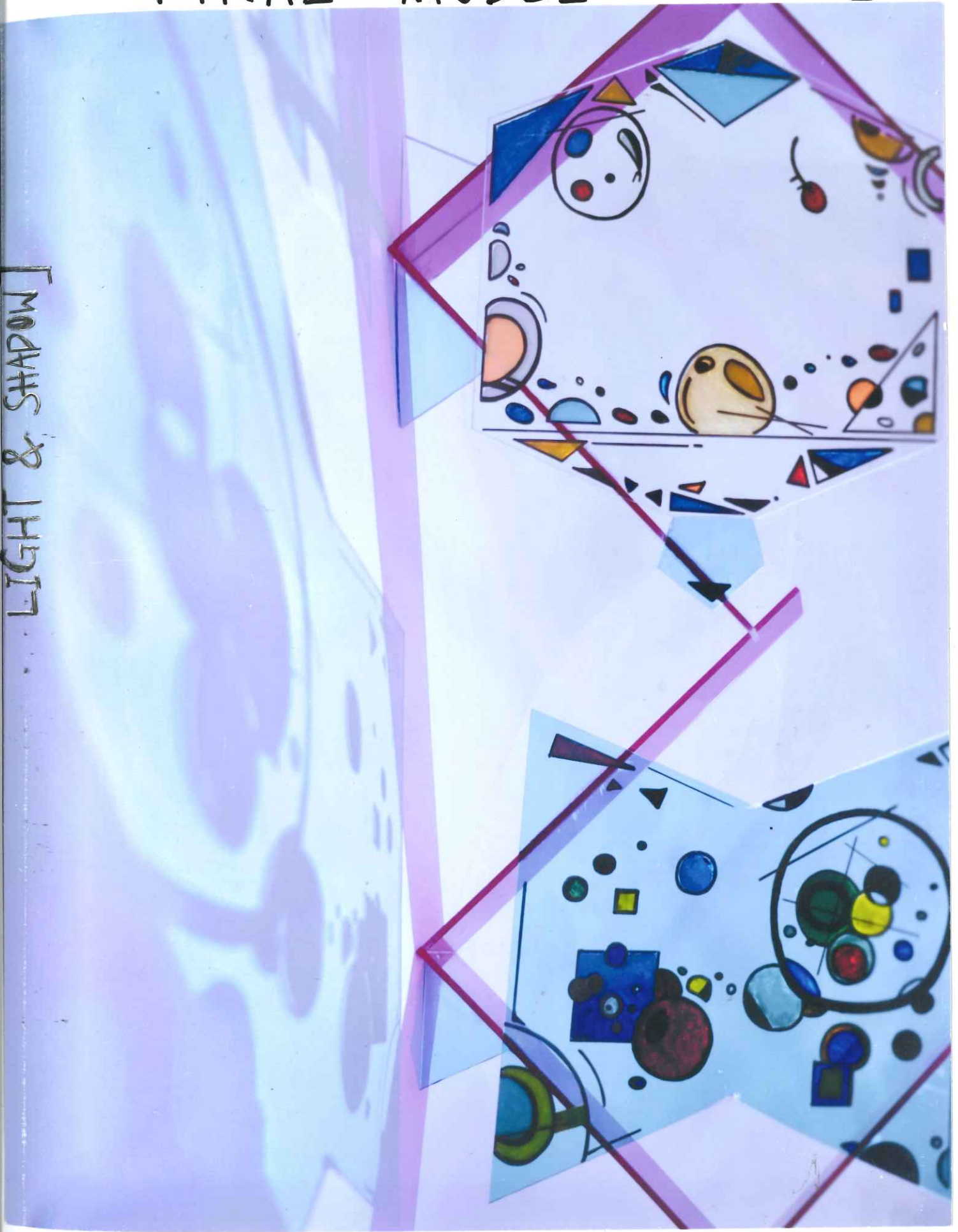

REFLECTION

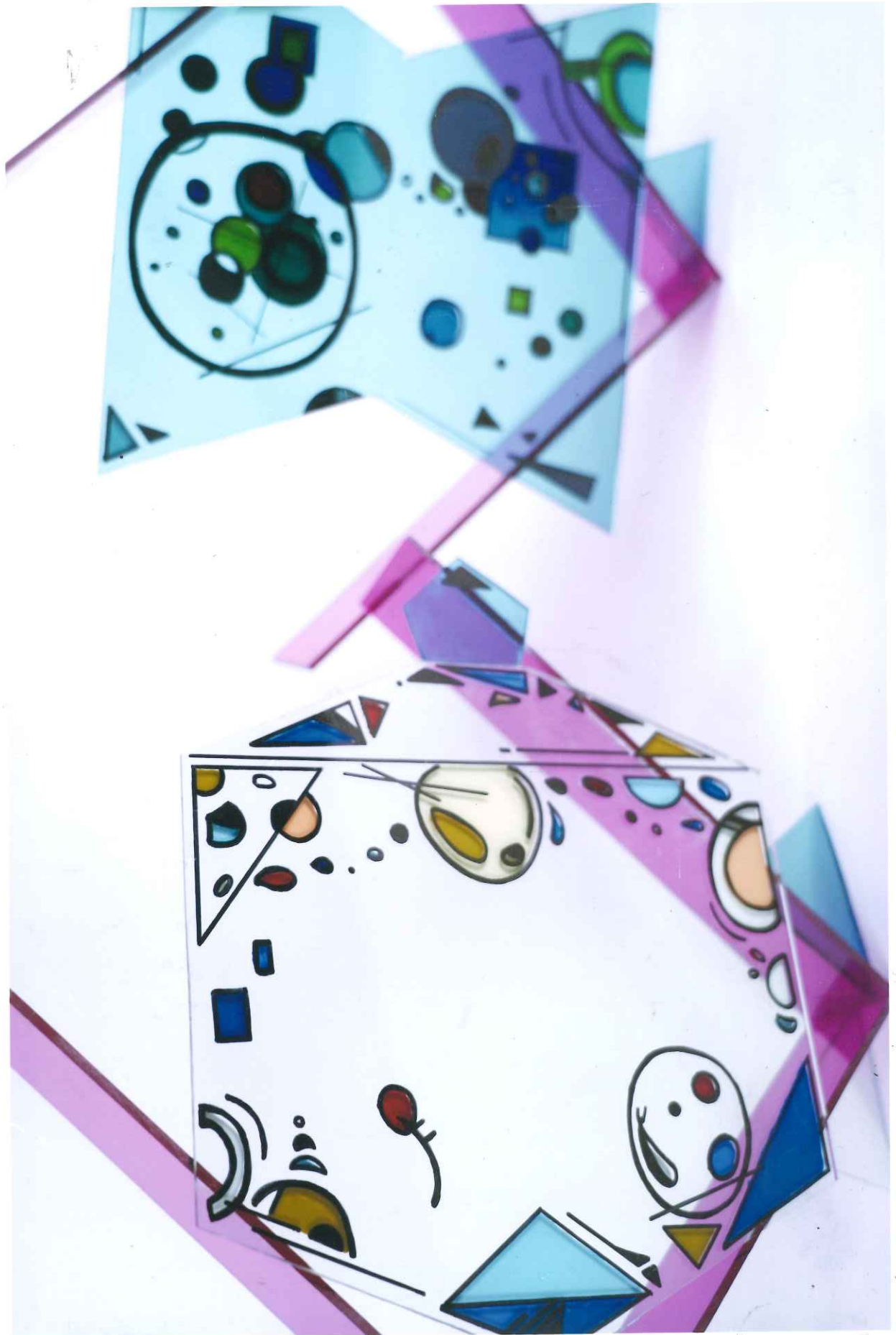

Acrylic
paint

Forms and shapes
inspired by Franz
Weissmann.

Patterns and designs
inspired by Kandinsky.

Material
inspired by Vasa
Mihich.

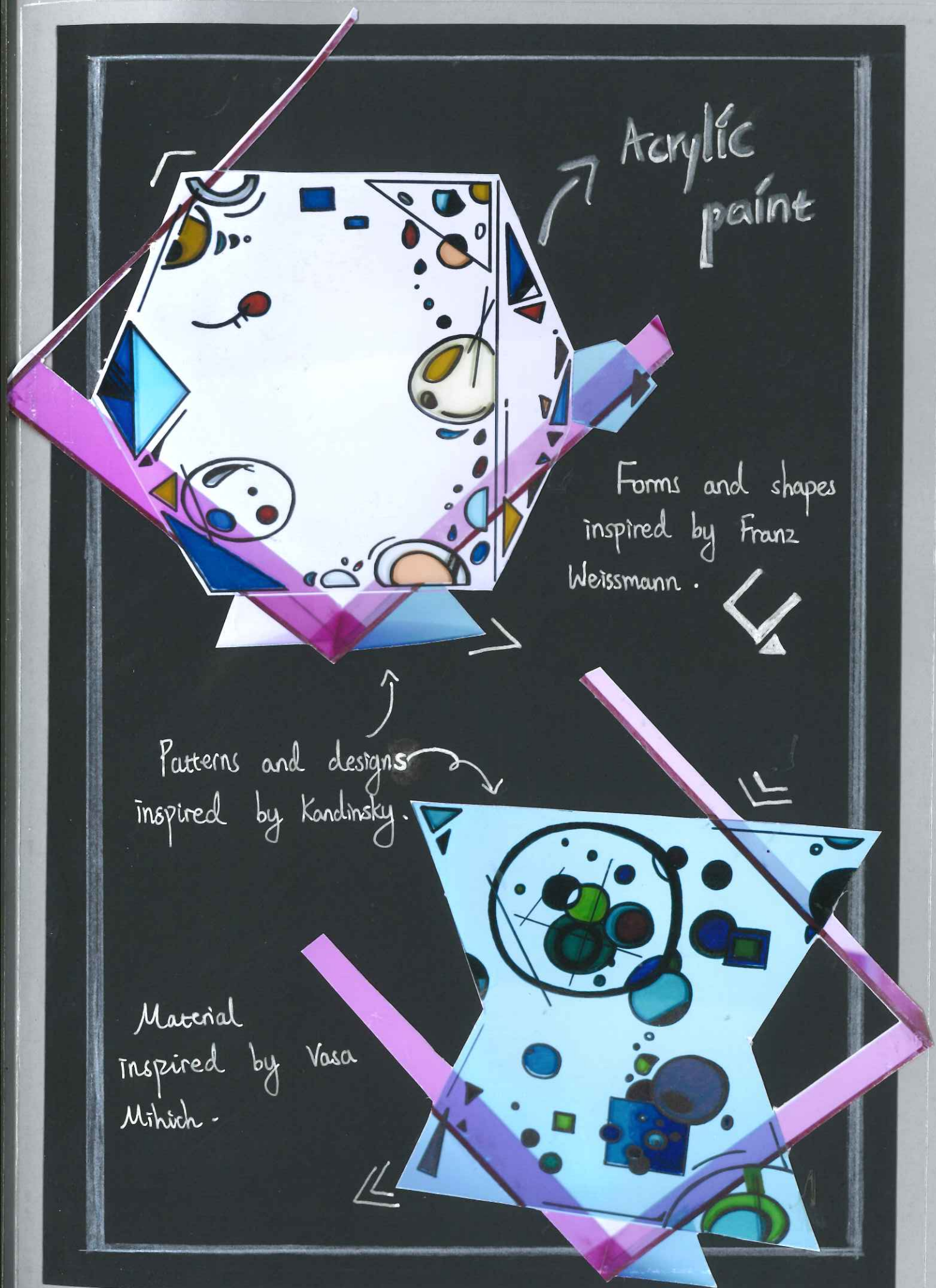

PROCESS →

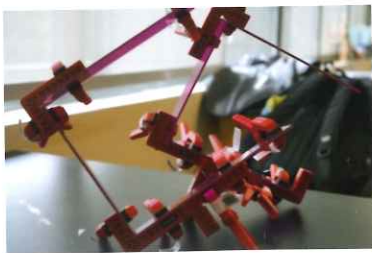
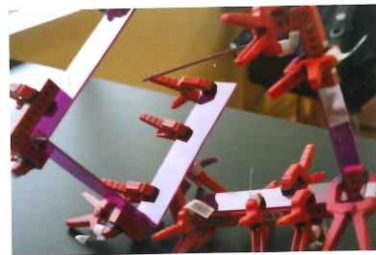
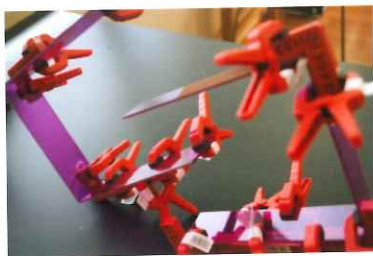
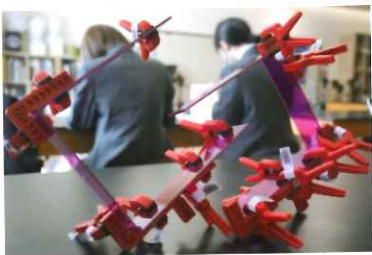
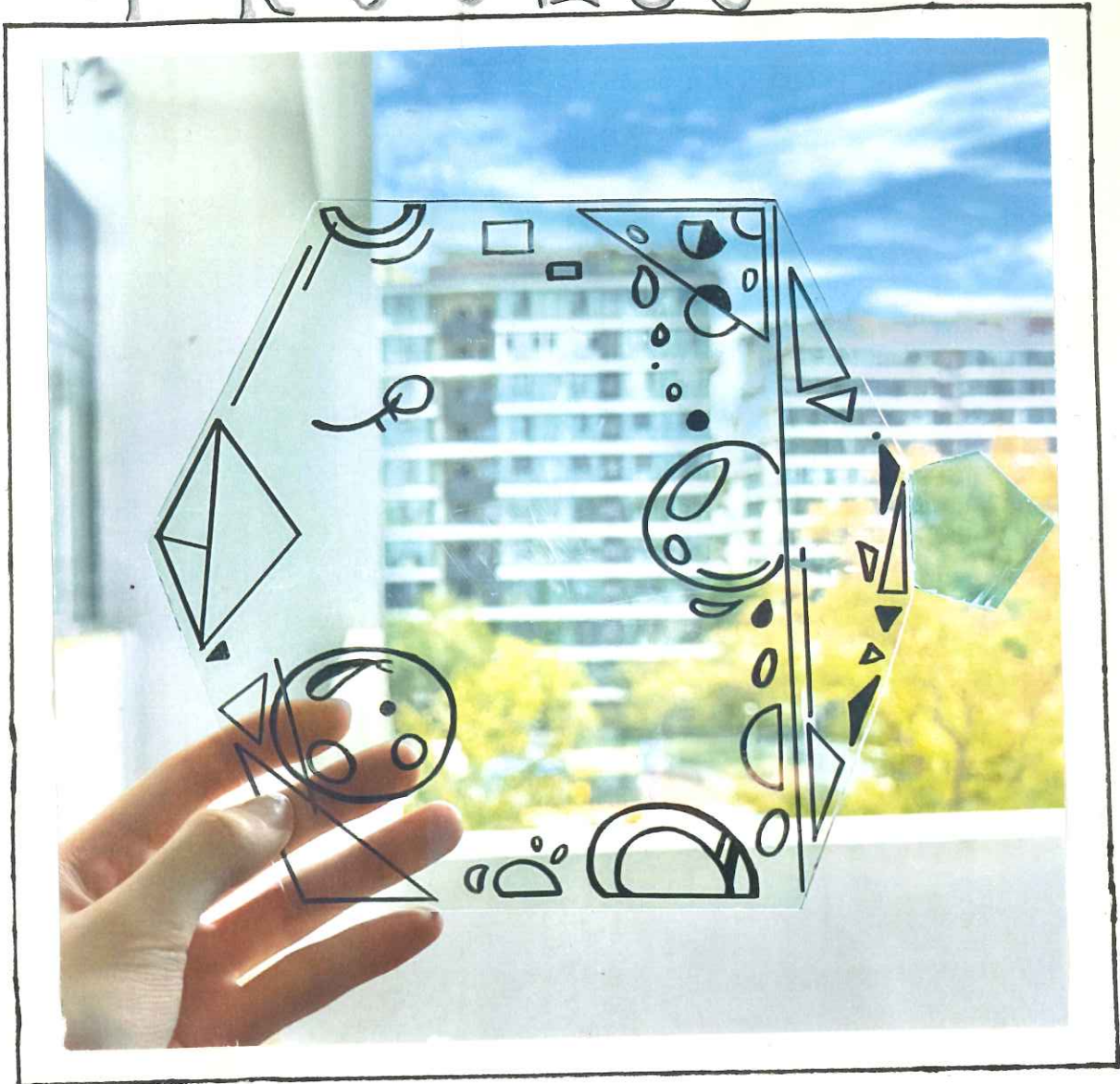

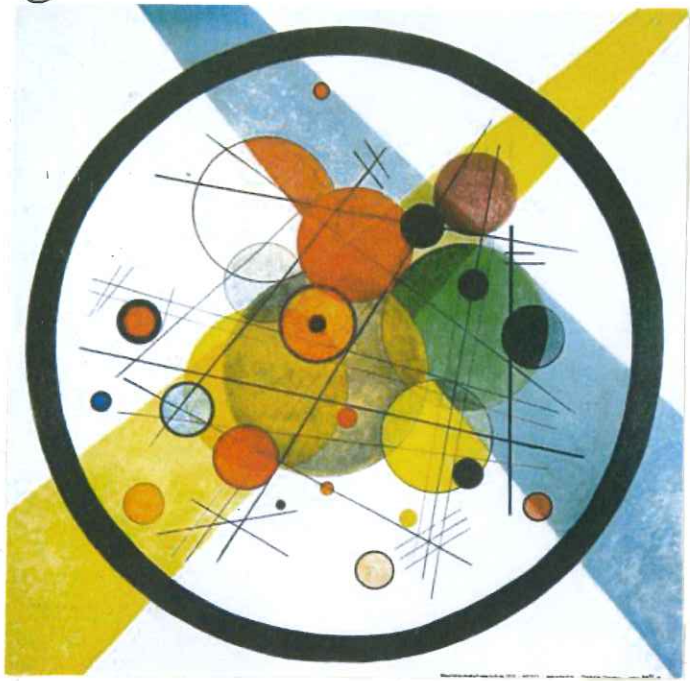

I've created a developed version of my acrylic model from the mock exam for my final outcome, therefore I still referred to Michich's works and used acrylic as my material.

This time I explored shapes and forms more deeply and

EVALUATION

I thought about the way how Weissmann designed his works. I was inspired by one of his works ¹ and designed the frame of my model as two symmetrical open squares, placed on the tip of the squares. I also used some of my extended ideas from before and included them in my work this time. I thought about putting two contrasting shapes on each frame and designed two shapes: one like a hexagon and the other like an hourglass → one goes out on both sides and one goes in on both sides. I referred to Kandinsky's ² works again and used my previous designs made on PowerPoint to doodle on the surface of the two acrylic sheets. I really tried my best to paint the acrylic sheets as neatly ¹ as possible, and also made sure that I painted them thick

enough since the acrylic paint on my previous model seemed too thin and didn't look so neat visually - I really like pastel colours so I chose a pinky colour for the frames and a minty, transparent colour for my two acrylic sheets. I also focused on colour combinations and tried to make the colours as natural as possible, also trying to make the colours blend into the acrylic sheets.



SARAH JENKINS

✦ CAITLIN JENKINS

The clay structure is the earthy foundation, the surface marks, colours and textures are transient moments of weather and light, season and time.

→ She is constantly on a quest for the right resonating frequency, a human response, something describing nature and the rightness of it.



Sarah Jenkins

I find the colours easeful and cosy.

I also like the feeling of minimalism through her patterns and designs.

Shows landscape in an internal, abstracted and oblique way.

Felicity is an artist of international standing, recognised for her research into large-scale ceramics.



SCRIBBLE

Felicity Aylieff

Appears like random splashes of paint, provokes an immediate sense of awe.

FELICITY ARTLIES



A piece by Sarah Jenkins slips are simple and oxides with scant glaze.

Sarah Jenkins

Caitlin is the 8th generation of Jenkins Potter.



Caitlin Jenkins



Sarah Jenkins

TWILIGHT LANDSCAPE VESSEL

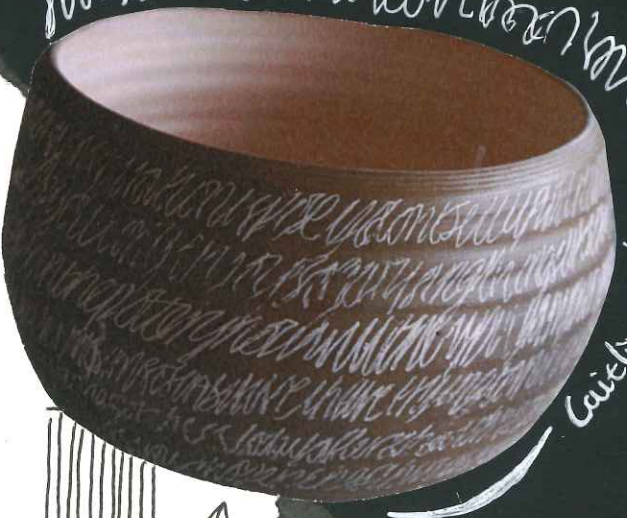

I find the design really interesting since it appears like continuous writing, giving the piece a mysterious and thoughtful feeling.



machinery he remembers seeing while growing up in rural southeast Kansas.

Bowie Croisant's earliest appreciation for form and function is the farm

He uses Computer Aided Drafting, or CAD software, to design forms for slip cast components that are assembled to shape his sculpture and functional ware.

His work is in multiple public and private collections including the Norman Museum of Contemporary Art.

"I have found myself continually returning to the idea of cumulative information, asking myself questions such as, 'how can information reveal itself through repetitive process?'"

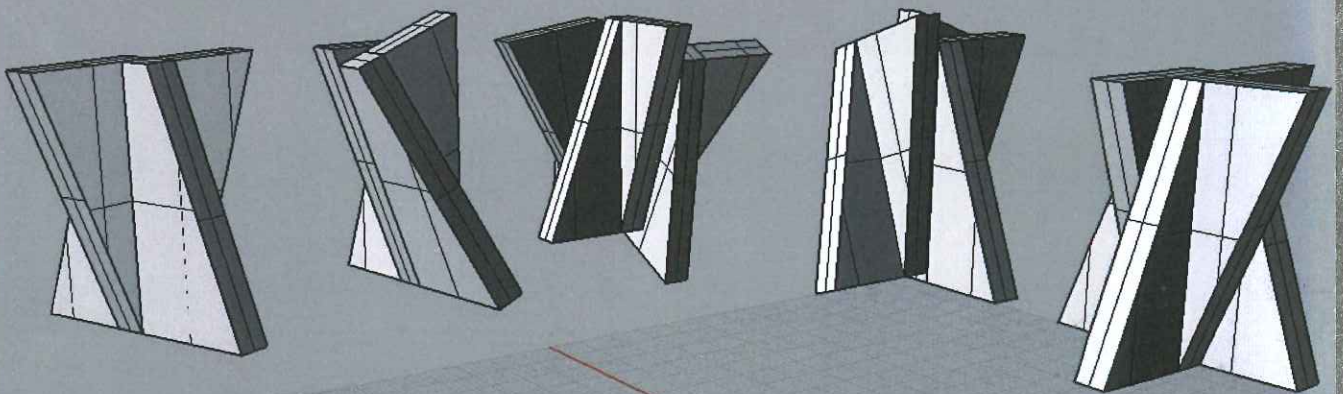

BOWIE

CROISANT

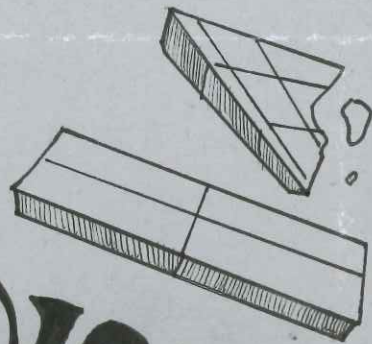

I really like the way Croissant combines shapes together and I find his ideas and concepts interesting. I also want to cut pieces of clay into geometric shapes and combine them together to create a

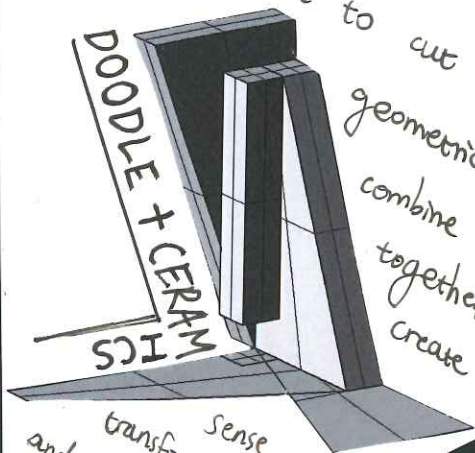

Sense of transformation and development.

GEOMETRIC DESIGNS

4 DIFFERENT ANGLES

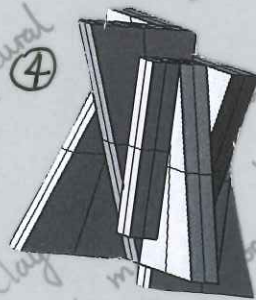
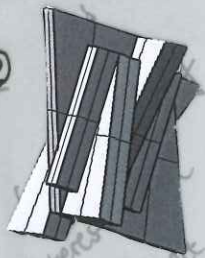
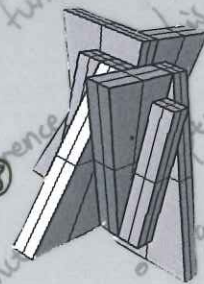
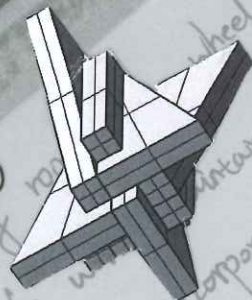

"My work is initially of a functional nature. It contains a reference to the early days of modernism as well as to the geometric explorations of the Bauhaus school through functional forms." "Clay is a material that allows me to explore anything I want to in my studio of the day."

FINAL PIECE

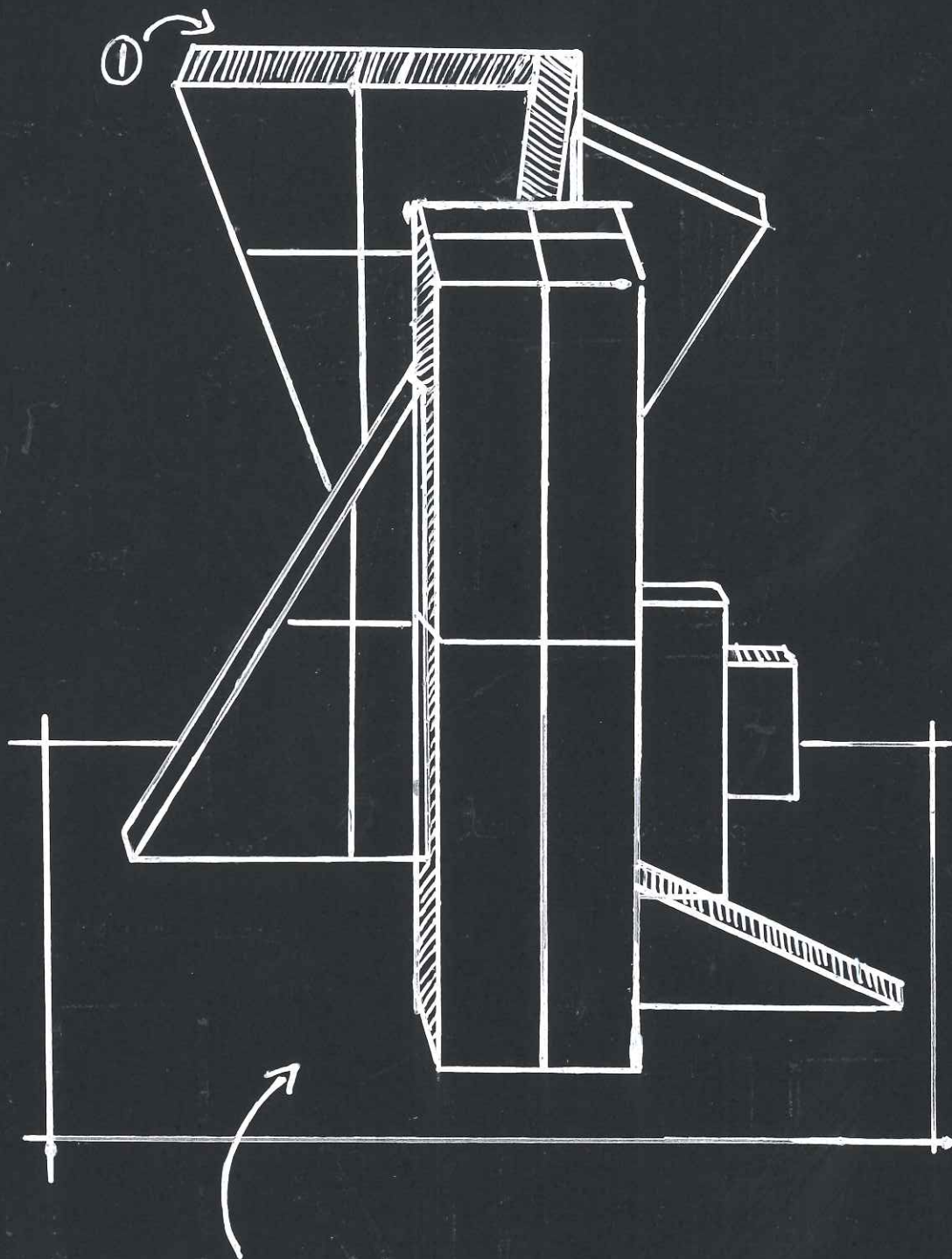

Shapes and forms inspired by Croissant.

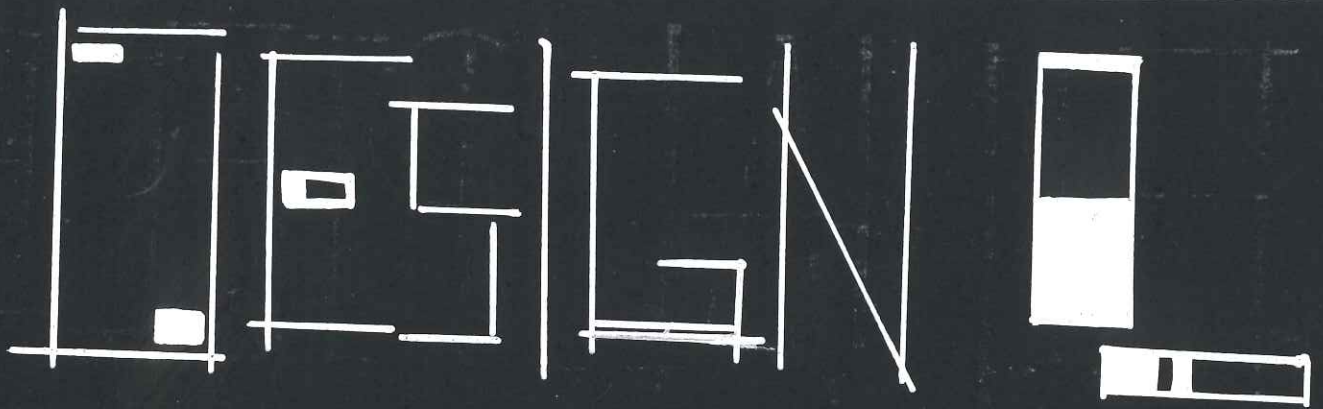

①

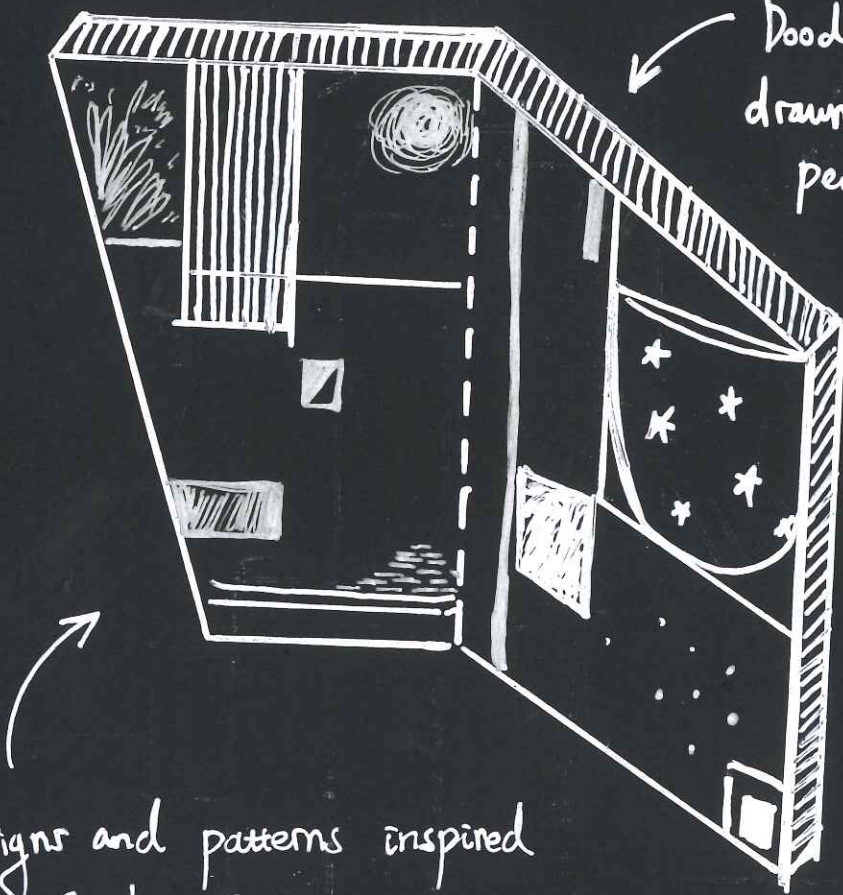

Doodles can be drawn with underglaze pencils.

Patterns can be developed from the base of the ceramic.

Designs and patterns inspired by Sarah Jenkins.

SHAPES

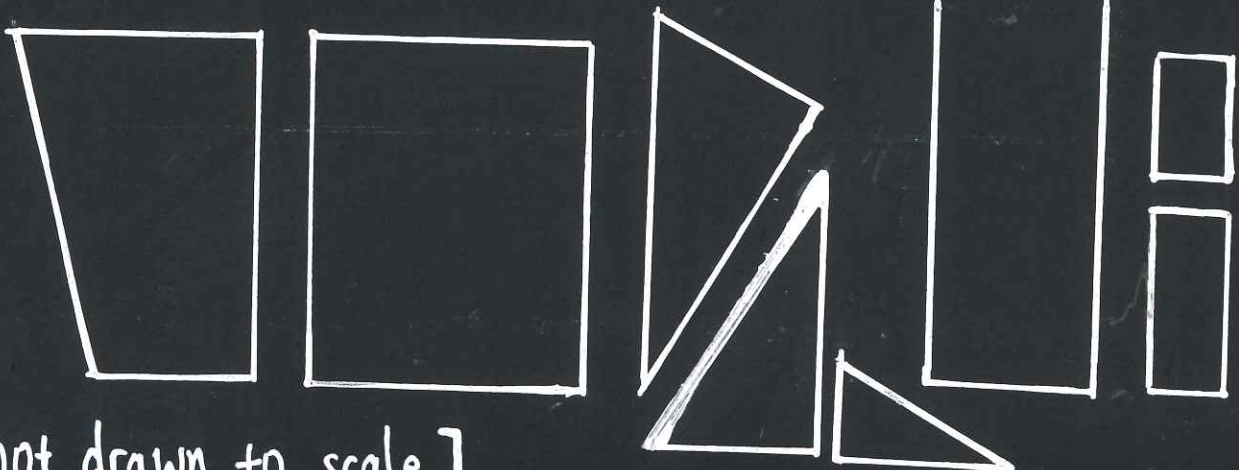

[not drawn to scale]

PAPER

MODEL

Side ①

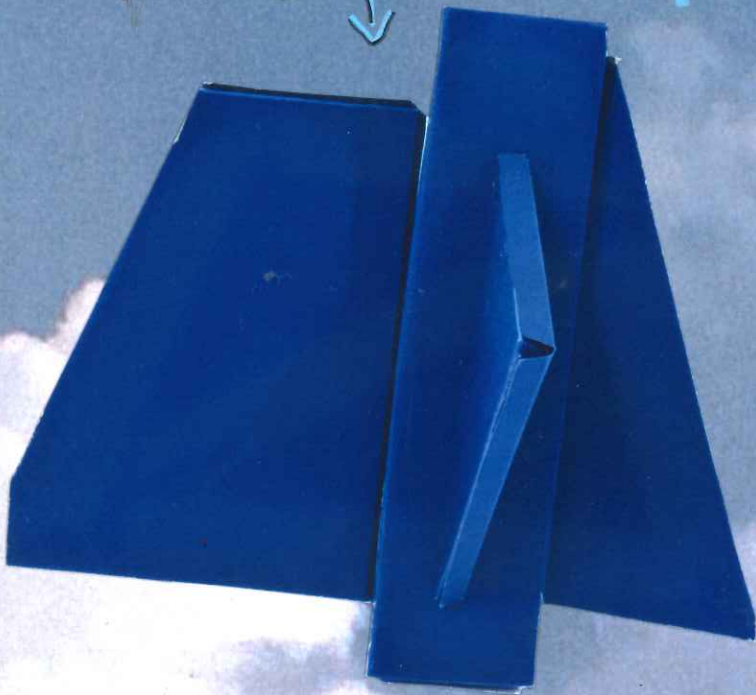

front

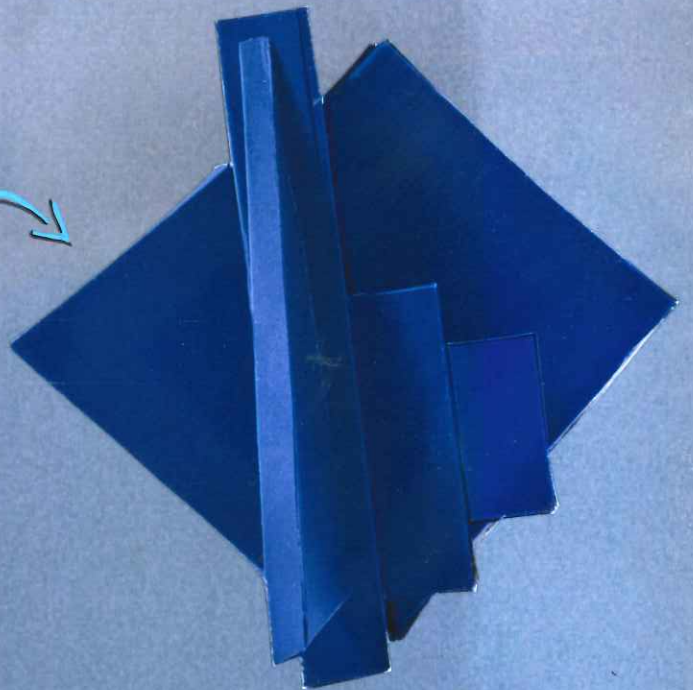

Side ②

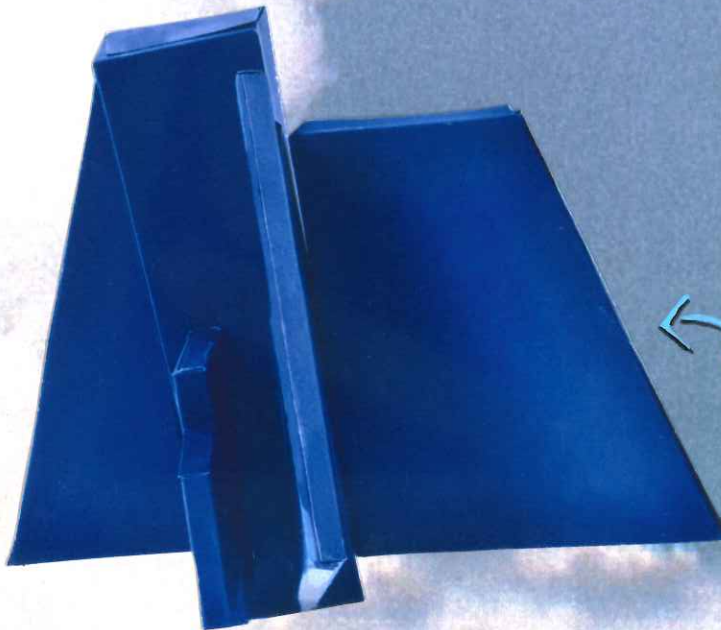

[DESIGN ②]

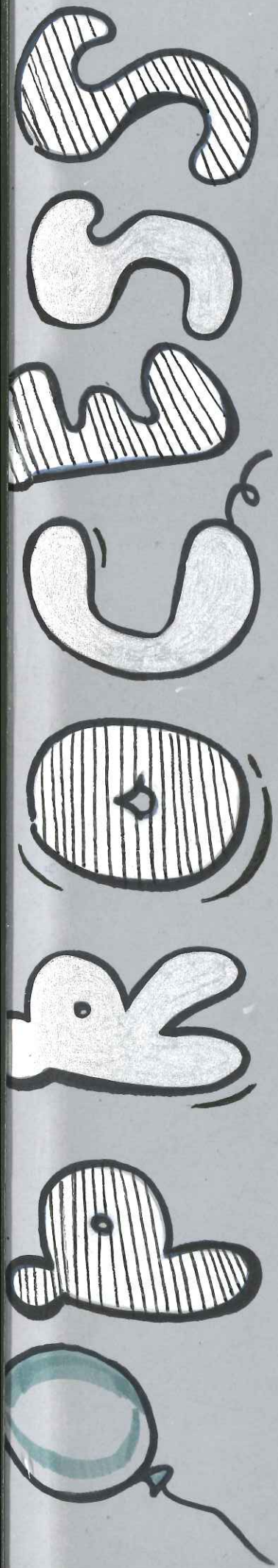

PATTERNS

Patterns inspired by Sarah Jenkins.

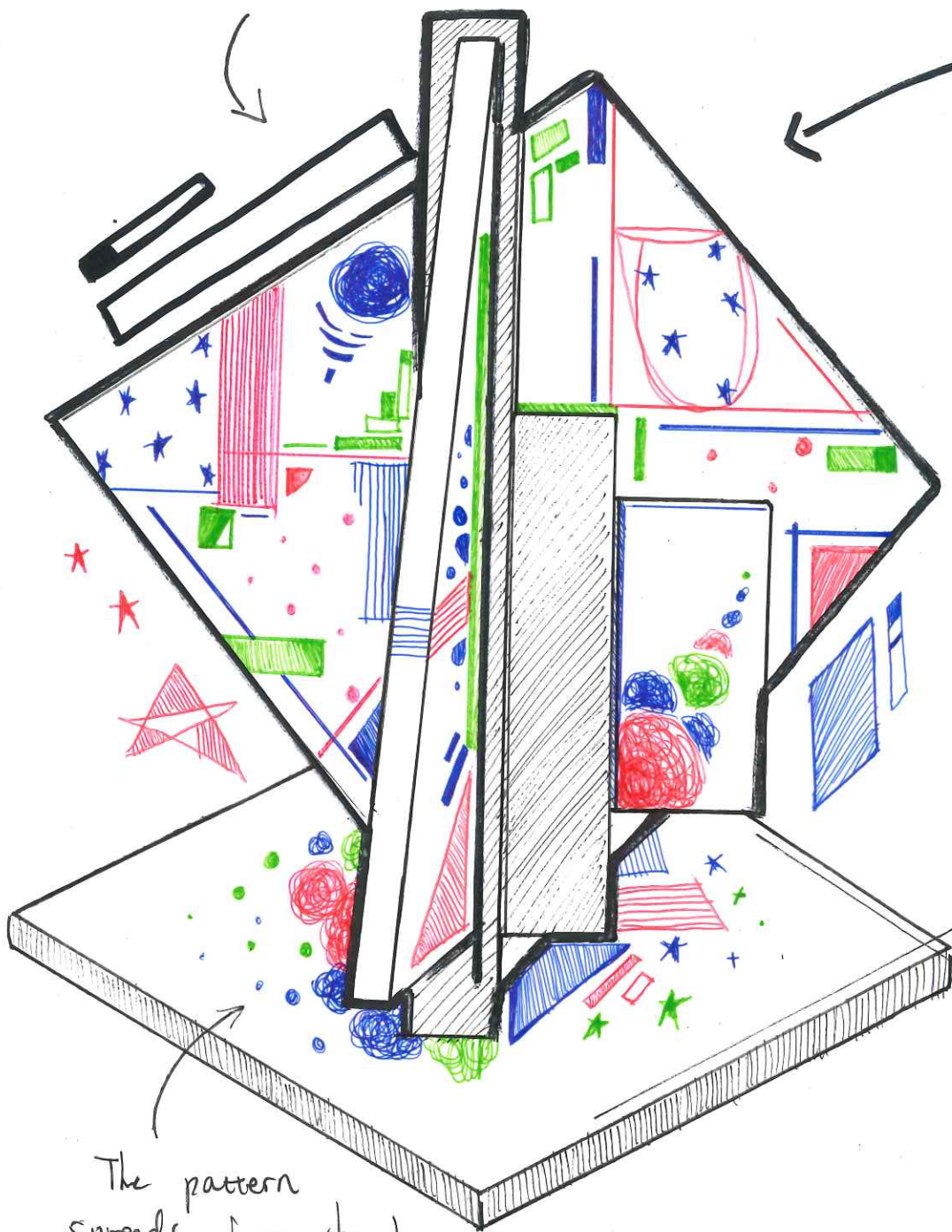

The pattern spreads from the base.

& DESIGNS

The piece at the back.

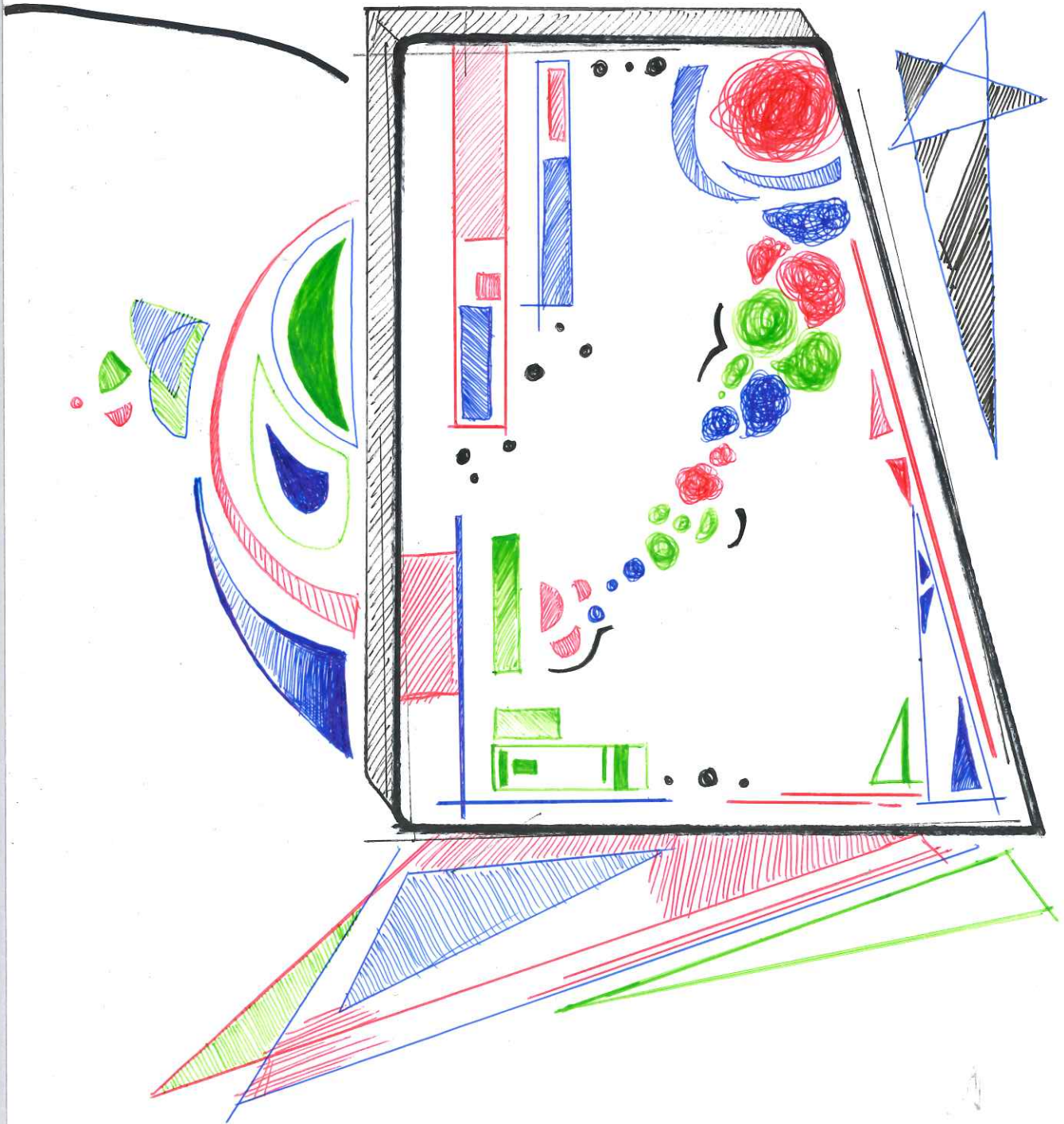

Further

Patterns crawling up
from the base.





A clearer
idea is developed

Swarm



A murmuration of starlings

I'm inspired by the animal kingdom and the natural world, mainly by the hive mind of the different

animals. The way

they work and live as a group is a particularly fascinating thing to see. I really want to use this idea in my project and show the instincts

of the animals aesthetically. I

also want to create the feeling of

invasion, as if

the animals are

overtaking the building aggressively, making it its territory while reflecting the theme of the power of nature.



The anthill



A School of Fish

After the research and the inspiration of the animal kingdom, I obtained the idea

of a school of fish. Marine organisms give me the thought of liberty, intensity, and beauty. I'm aiming to create a piece with a school of fish invading and swimming upwards on the sculpture aggressively. I also want to add some patterns to the fish to create a dreamy and mysterious feeling, as if they come from the



distant past. Overall, I find the ocean a fascinating place and a place filled with mystery, danger, and wonderful organisms.

FRONT

DESIGN

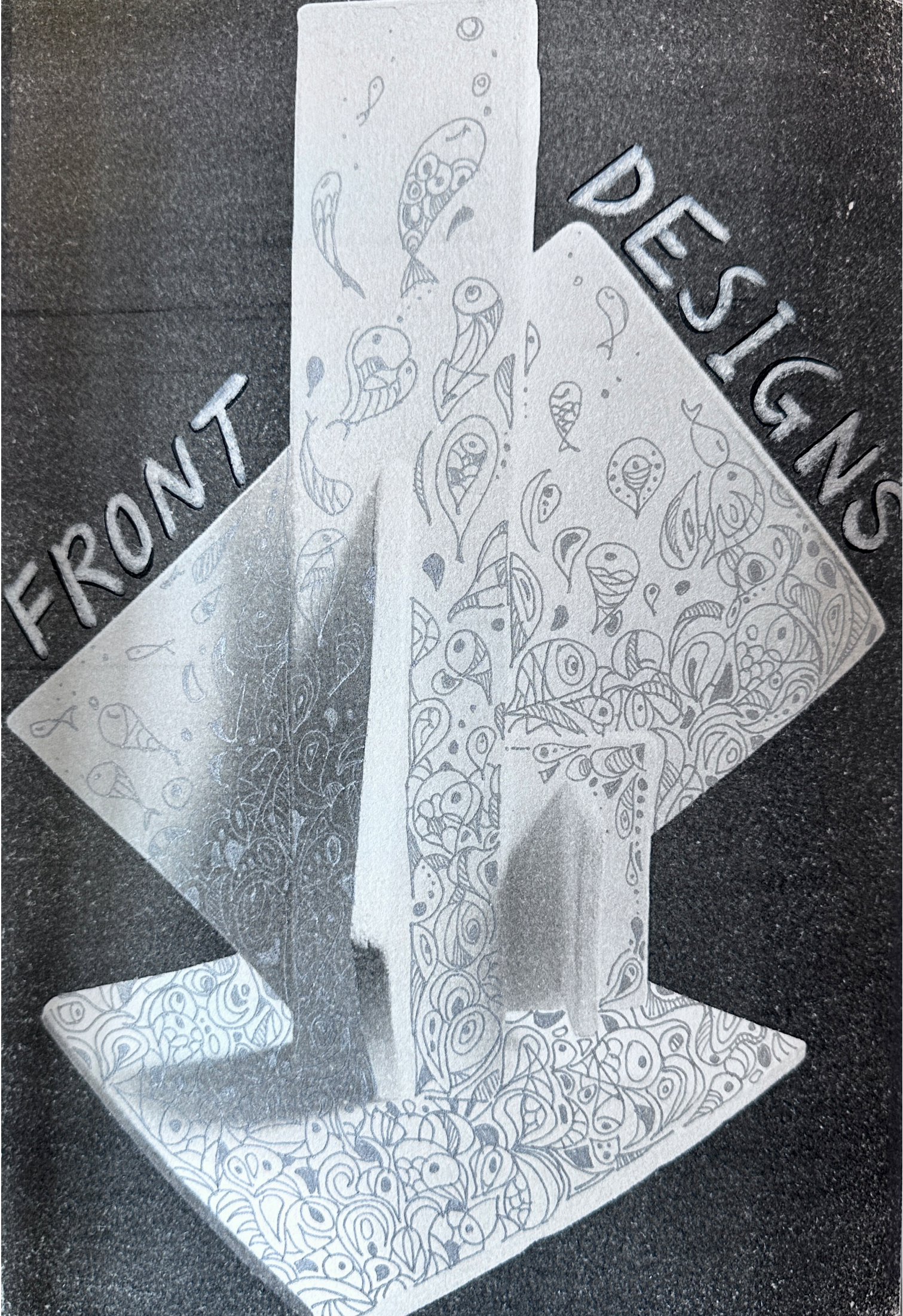

BACK

DESIGNS

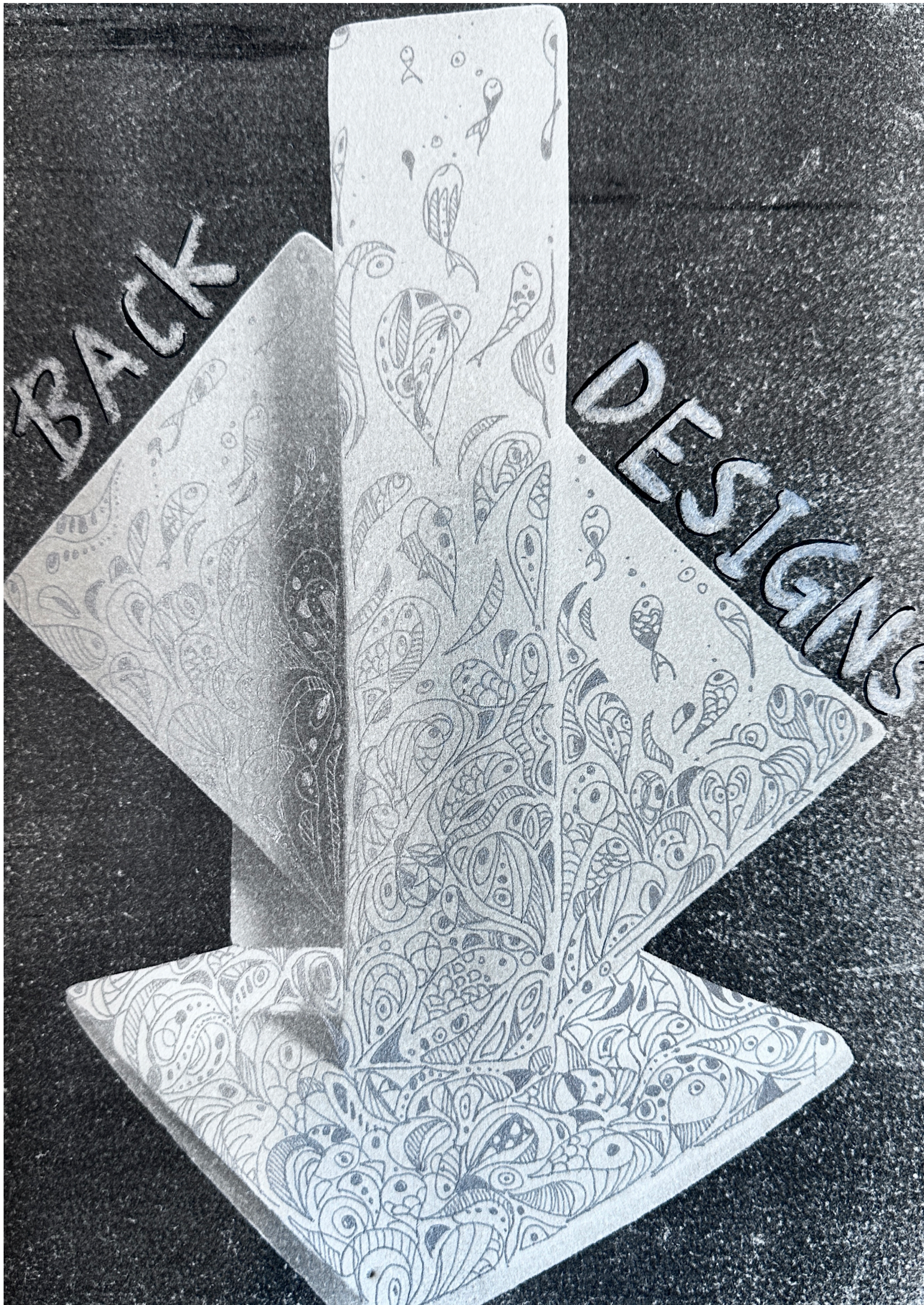

Ceramics is not a material that I'm really familiar with, but it is the perfect material to create the sense of 3D. At the start, I was aware that there was a 50% chance that the ceramic sculptures would crack in the kiln, so I knew I had to make two pieces for safety. I daubed myself for using the materials that I wasn't familiar with but I still accepted the challenge, knowing it was a great opportunity to explore new materials and techniques, also allowing me to show my skills and ideas. I was first inspired by Bowie Croissant and had the idea of joining geometrical ceramic pieces, creating a powerful visual impact. The concept of his works also suits the theme of the coursework: Merging Forms, so I started designing the shape and form for my final pieces using some of Croissant's ideas. I made some sketches and paper models to help me visualize my sculptures' shape and some templates for cutting out the ceramic pieces. I then found three artists: Sarah Jenkins, Felicity Aylieff, and Carlin Jenkins. They all have their own distinctive style of creating ceramic pieces, making interesting patterns and designs on their pieces which inspired and motivated me to create my piece. I tried out many conceptual designs and had the idea of doodling multiple layers of patterns on the base of my sculptures and gradually building the patterns up, transforming them into specific beautiful designs. I then started cutting the shapes out of ceramics and combining them together. I used white porcelain for

my first piece to create a pure and effect and a slightly darker, firm type of second piece. I started drawing with pencils as soon as the sculptures were dried and I found drawing unexpectedly difficult on surfaces. I had to be careful not to smudge and ruin the overall effect. My first piece came

elegant clay for my underglaze and ready, the sculptures' the colors out to be colors and piece is larger to expand Overall, I it was a high-quality techniques a stronger

neat and dreamy, filled with lots of organized designs. The size of my second than the first piece, so I had the opportunity my designs referring to my final conceptual design. Spent a long time making my final pieces and real challenge for me to quickly produce two ceramic sculptures. I obtained many different while making the sculptures and developed personal style for making graphic designs.

A mini analysis of sculpture :

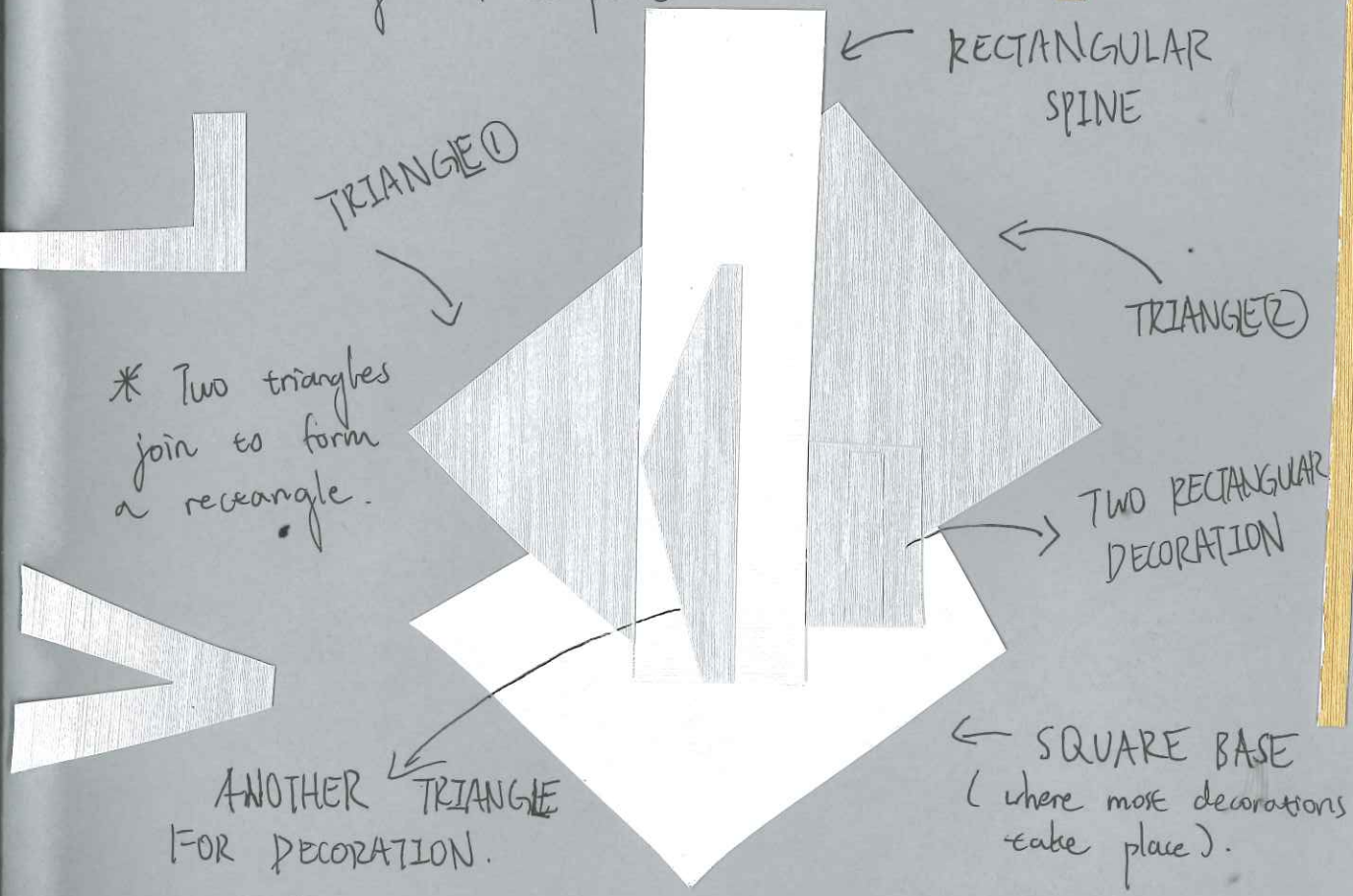

Final Coursework Evaluation

Initial theme-Merging Forms

'Merging Forms' is a unique theme for me. It gives me ideas for combining shapes and forms, which have a strong sense of geometry and can also have a strong visual impact when people look at different angles and sides. I then began with artist research on Franz Weissmann and David Bill, both great sculptors whose works have a great sense of 'merging'.

Starting my project

I was inspired by David Bill and started my project by referring to his works. His sculptures really stood out to me and I found out that the key ideas to his works are 'balance', 'minimalism', and 'steepness'. I then tried different PowerPoint designs by rearranging my shapes into different forms to find a balanced position. In the end, I ended up with five initial designs and chose my favorite design out of the five. I played around with different colors and gradients on PowerPoint and chose blue as my final color. I decided to use a paper model to display my final design since I think a paper model can best show depth, details, and color. I combined several triangles, and the shadow and depth varied under different light sources, which had an interesting effect.

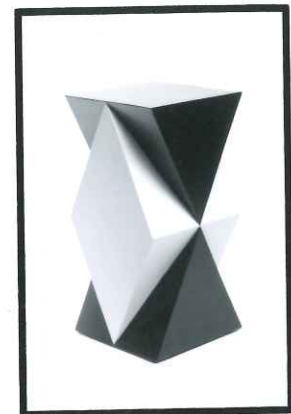

David Bill



Kandinsky

Developing my model

I thought about making detailed designs to decorate my model, therefore I continued with artist research on Kandinsky. Wassily

Wassilyevich Kandinsky was a skilled painter who used to create abstract paintings. I found his use of patterns, shapes, and colors very thoughtful, so I used PowerPoint and added different colors of shapes to my previous designs. I tried not to use colors that are over-saturated since I wanted the main focus to be the form and shape of the 2D designs. Finally, I used navy blue paper to make my final model. I cut out different shapes from different colors of paper and stuck them onto the paper model according to my PowerPoint designs. I also added more shapes to the different faces of the model and used bright colors to emphasize the sense of shape and form of the paper model. My sculpture is also made up of several triangles, therefore the use of triangular decorations corresponds to the overall shape, and the circles soften the edges and make the model smoother. The additional lines also add novelty to my model. It was my first time making a paper model, so it looked a bit rough, but I think it was a meaningful attempt.

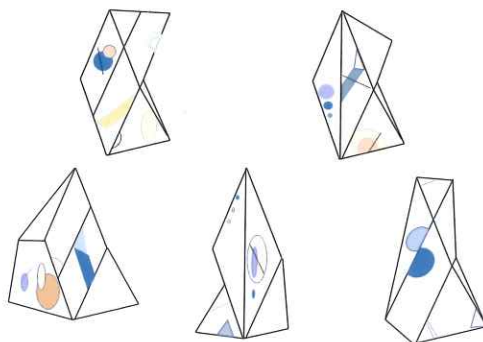

Exploring a brand-new material: Acrylic



After making my first model, I moved on to a brand new artist research on Vasa Mihich, an artist who makes sculptures out of acrylic. What made me research artists who use acrylic as their main material is that I find acrylic an exciting material for representing shapes and forms. I love the transparency and the great variety of colors in acrylic, and I think it can create a sense of fragility and aesthetic feeling. The shapes made out of acrylic may appear like

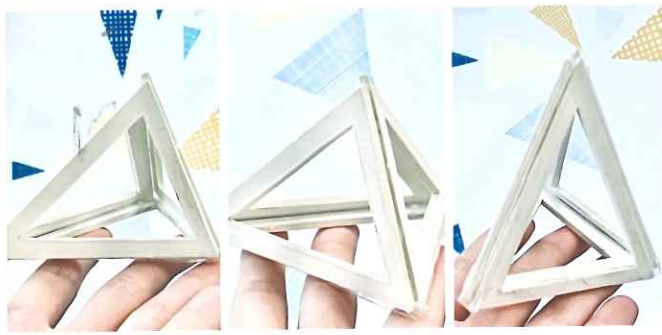

glass, looking dynamic and endlessly fascinating. I think it is also a great chance for me to investigate color and light, exploring the optical characteristics of acrylic through shapes and forms. I

then referred back to my previous artist Franz Weissmann and started making some testing models out of paperboard, which has about the same thickness as the acrylic sheet to explore the shape and form before I make my final piece using acrylic. I cut out several triangles to combine them in different ways and carved out the inside of the triangles to build up my skills for cutting thick and hard materials. I also used the spare pieces of triangles to make my model more complex and advanced.

Drawing on acrylic!

I bought some acrylic sheets after building my cutting and designing skills. I tried to explore doodling different patterns and shapes on paper, then moving on to doodling on the surface of the acrylic sheet referring back to Kandinsky's works. I first used a Sharpie to doodle the outline of the patterns and used acrylic paint to color the shapes. I tried to play around with the shapes referring to Kandinsky's works and added my extended designs. I chose



Test Piece

to draw and paint on different sides of the acrylic sheet to make it look more layered and to give it a unique texture. I used various colors for the model: transparent, purple, and orange for the frame

of the model, orange for the base, and transparent for the triangular piece for doodling and designs. I find purple and orange vibrant and energetic, which makes the model vivid using the advantage of the great possibility in the colors of acrylic sheets. I looked back at Weissmann's works and designed the model to create a sense of space, by giving the model a foreground and a background. I spent quite a lot of time sawing the acrylic sheets and used super glue to stick pieces together. The final model came out to appear like the shape of a diamond and I tried to shine a flashlight on the model. I enjoyed seeing the acrylic model shining vividly like a diamond and was really satisfied with the final effect.

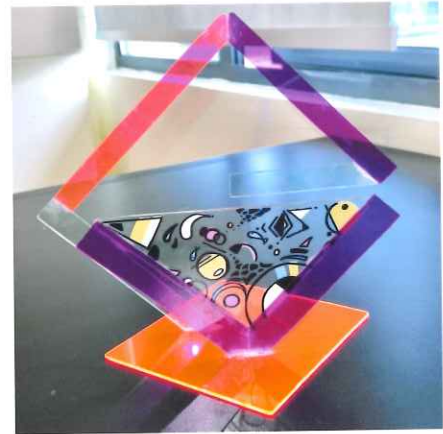

Further designs and the final piece

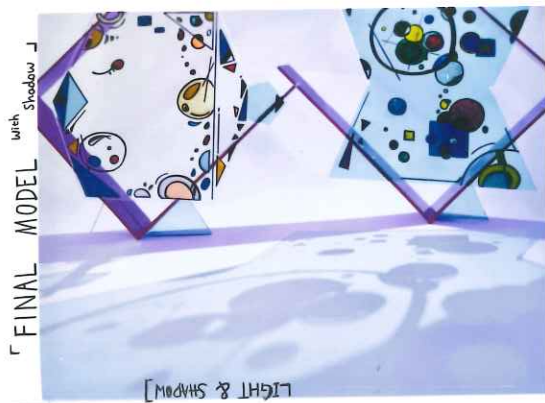

After my second piece, I made some further designs from my experience of using acrylic materials. I also used my extended designs from my previous piece and made some designs of fish and marine organisms. I focused on Weissmann and Kandinsky's works again and

started with a design of a fish going through an open frame in the shape of a diamond on a huge base. I then thought about a sculpture made by Weissmann and decided to make my final piece into two parts. I planned to make the two frames as two symmetrical open squares, placed on the tip of the squares, and thought about putting two contrasting shapes on each frame: one like a hexagon and the other like an hourglass, one goes out on both sides and one goes in on both sides. I then developed this idea using PowerPoint,

creating a template of the shapes and putting additional patterns and designs on it. After I finished the designs, I started sawing the acrylic stripes for the frames. I then used clamps to hold the pieces in place, which really helped me to have a better idea of the form and allowed me to rearrange the frames in different positions. After that, I started sawing the main acrylic pieces as neatly as possible and stuck them into position. This time, I used minty, transparent colors for the main pieces and a pinky color for the frames to create a dreamy and unique overall effect. I also tried to paint thickly on the acrylic sheets since the acrylic paint on my previous model seemed too thin. I also thought about combining shadow with my acrylic model, using different light sources. Therefore, I took pictures of my final model using a white backdrop and flashlight. I was really pleased with the final effect and the dreamy, colorful shadow as if it was a reflection of the model on a mirror. Overall, I tried to show the idea of light and shadow in both of my acrylic pieces since I found acrylic the most dreamy and suitable material to display the magnificence of the shadows produced by shining the lights onto the acrylic with patterns and designs.

Moving on to ceramics

I looked back at my previous works and decided to create a ceramic sculpture for the final piece of my coursework. It was actually a big challenge to me to make a ceramic piece since I wasn't familiar with ceramics, but I really wanted to develop a sense of three-dimension in my work, so I planned to move on to a ceramic sculpture with additional doodles and patterns on it. I then researched three artists: Sarah Jenkins, Felicity Aylieff, and Caitlin

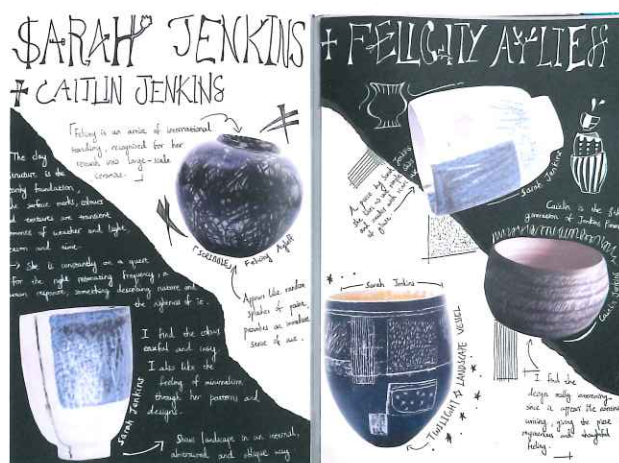

Jenkins. These artists all make interesting patterns in ceramics, which really inspired me to create my own piece. I then researched an artist called Bowie Croisant, who combines shapes to create a sense of geometry. I found his concept of transformation and form interesting, and it suits perfectly the theme of Merging Forms. Therefore, I started to create my own designs, sketching out geometric shapes referring to Croisant and doodled patterns referring to Sarah Jenkins. I then tried to rearrange the shapes and made my second design in a paper model to better understand the



Sculpture 2

three-dimensional version of my final ceramic piece. After that, I made some basic templates, rolled out some white porcelain, traced around the templates, and cut out the shapes. I chose to use white porcelain since the color is so pure that it is the best material to present different colors and patterns. I used a sponge to smoothen the sides and edges of the pieces and stuck the pieces into position using a slip. I also made another similar sculpture using a different type of ceramic, in case one of them cracks. This time I tried to enlarge the shapes, so I have more space to doodle on the surfaces of the sculpture.

Patterns and Designs

I then thought about the detailed designs to doodle on my final sculptures by using ideas from the three artists. I explored two different styles on two of my sculptures. I first took inspiration from Sarah Jenkins and tried out an organized, dreamy style with some of



Sculpture 1

my own extended designs on my first sculpture. I was also inspired by Felicity Aylieff and explored a more busy, aggressive style in my second sculpture. I tried doodling multiple layers of patterns on the base of my sculpture, and gradually building the patterns up along the different pieces as if the patterns are invading like an intruder. The patterns are also transforming into something neat and beautiful, and the specific designs are gradually revealed.

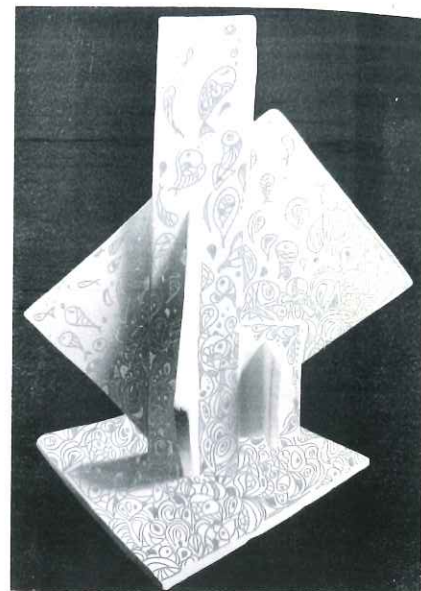

Final pieces



I used underglaze pencils to doodle on the surfaces of my sculptures and decided to make my first sculpture colorful with the use of pastel colors to represent an imaginative, dreamy story, and the second sculpture black and white to depict more complex and intense patterns and designs. I chose

fish as the second sculpture's main theme since **I was inspired by the spectacular shoal and felt the powerfulness of nature and the animal kingdom.** I also found that fishes are the most suitable animal for representing the idea of invasion because they are such vivid and magnificent animals to depict. It was really a difficult job to doodle neatly on a 3D sculpture and I had to make sure the lines are straight, and that I don't smudge the colors. I was relieved that the sculptures didn't crack when they came out of the kiln, and I'm glad that both sculptures look great.

Conclusion

Overall, I'm really pleased with all the work I've produced and the progress I've made throughout my coursework. I focused on the theme of 'merging forms' and explored different ways of reflecting the theme from my works inspired by different artists. When I started the coursework, I was not confident using different materials to construct 3D projects. But as I explored further through the coursework, I began to develop many techniques and had the confidence to explore different materials: paper, acrylic, and clay. While developing my skills in constructing 3D projects I also improved my techniques in graphic design and became more creative. As a result, this course helped me understand many concepts and allowed me to develop techniques in all aspects.

OUTCOME 1

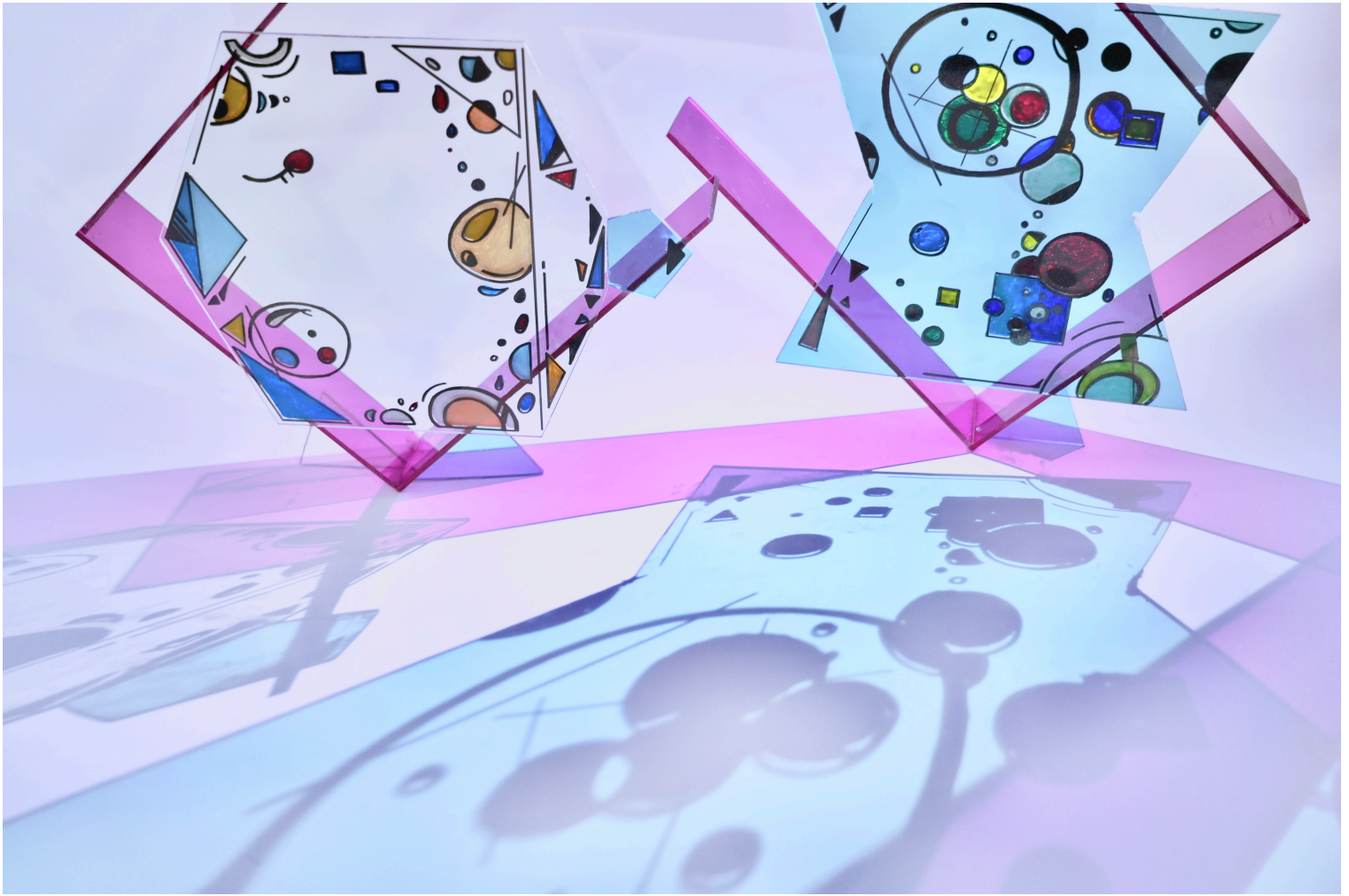

OUTCOME 2

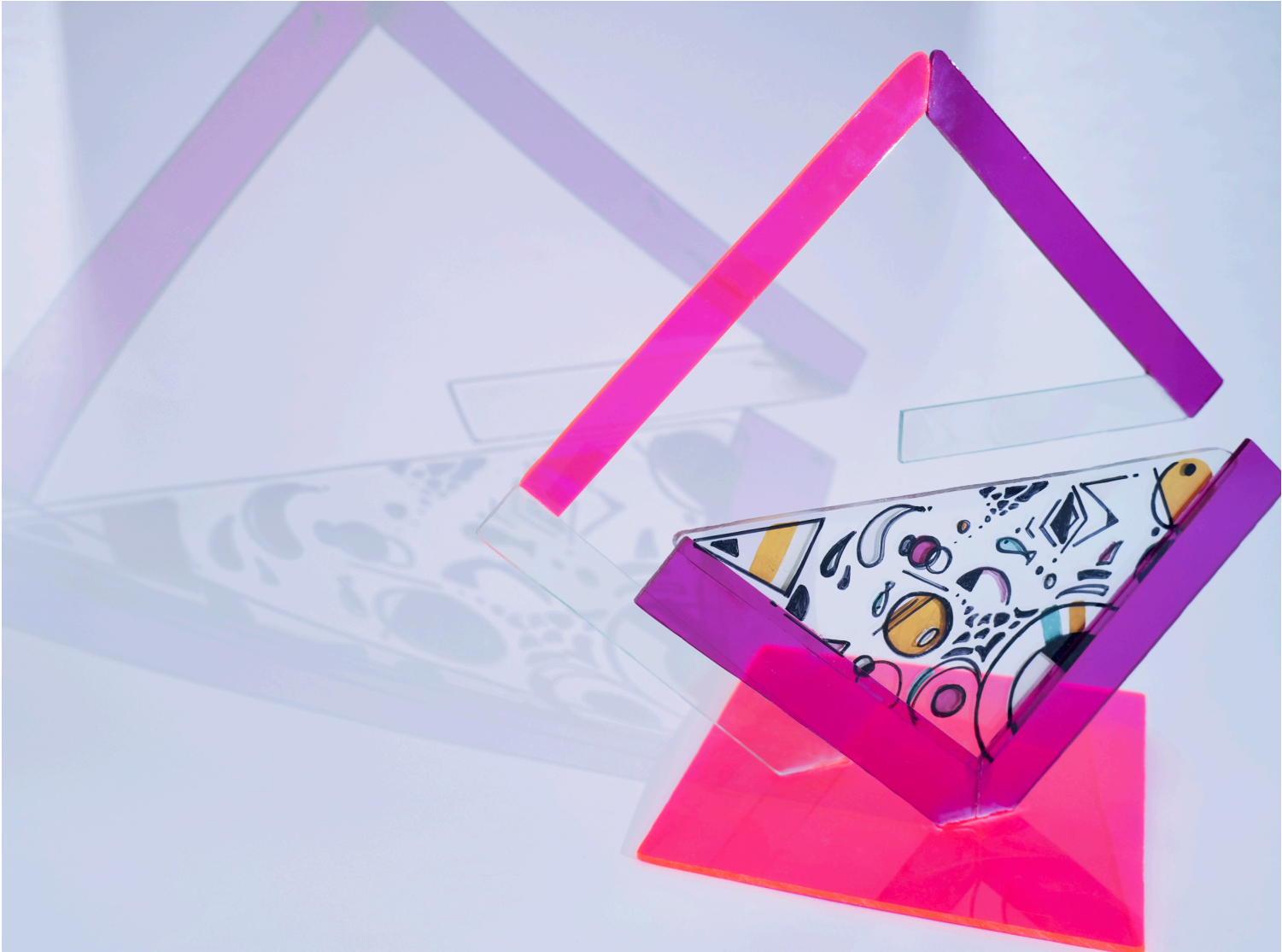

OUTCOME 3





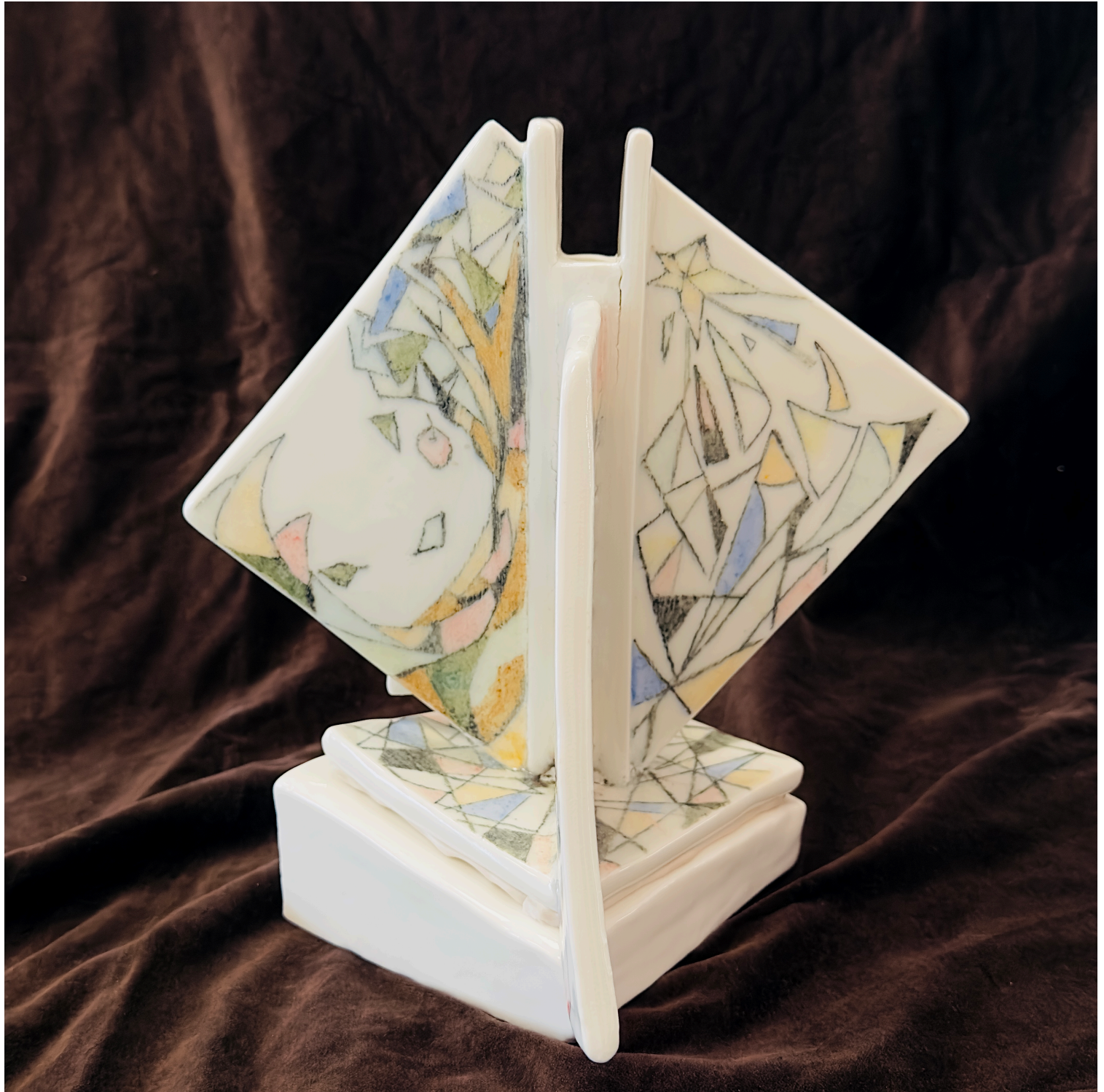



OUTCOME 4







