

Write your name here

Surname

Other names

Pearson
Edexcel Award

Centre Number

--	--	--	--	--

Candidate Number

--	--	--	--

Statistical Methods

Level 1

Calculator allowed

Monday 18 January 2016 – Morning

Time: 1 hour 30 minutes

Paper Reference

AST10/01

You must have:

Pen, HB pencil, eraser, calculator, ruler, protractor.

Total Marks



Instructions

- Use **black** ink or ball-point pen.
- **Fill in the boxes** at the top of this page with your name, centre number and candidate number.
- Answer **all** questions.
- Answer the questions in the spaces provided – *there may be more space than you need.*
- **Calculators may be used.**
- If your calculator does not have a π button, take the value of π to be 3.142 unless the question instructs otherwise.

Information

- The total mark for this paper is 80
- The marks for **each** question are shown in brackets – *use this as a guide as to how much time to spend on each question.*

Advice

- Read each question carefully before you start to answer it.
- Keep an eye on the time.
- Try to answer every question.
- Check your answers if you have time at the end.

Turn over ►

P47097A

©2016 Pearson Education Ltd.

6/6/8/







PEARSON

Answer ALL questions.

Write your answers in the spaces provided.

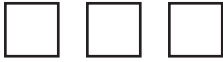
You must write down all stages in your working.

1 The pictogram gives information about the number of books sold in each of 4 months.

Month	Number of books sold
August	
September	
October	
November	
December	

Key:
 represents 4 books

(a) How many books were sold in August?

..... books
(1)

More books were sold in November than in September.

(b) How many more books?

..... books
(2)

In December, 17 books were sold.

(c) Show this information in the pictogram.

(1)

(Total for Question 1 is 4 marks)



DO NOT WRITE IN THIS AREA

DO NOT WRITE IN THIS AREA

DO NOT WRITE IN THIS AREA

2 Sandeep asks each of his friends the type of music they like best.

Here are his results.

Rock	Pop	Rock	Pop	Jazz	Classical
Classical	Rock	Rock	Jazz	Classical	Rock
Jazz	Classical	Jazz	Jazz	Rock	Jazz
Rock	Classical	Pop	Classical	Rock	Rock

(a) Complete the frequency table for this information.

Classical music has been done for you.

Type of music	Tally	Frequency
Classical		6
Jazz		
Pop		
Rock		

(3)

(b) Complete the line graph for this information.

Classical music has been done for you.

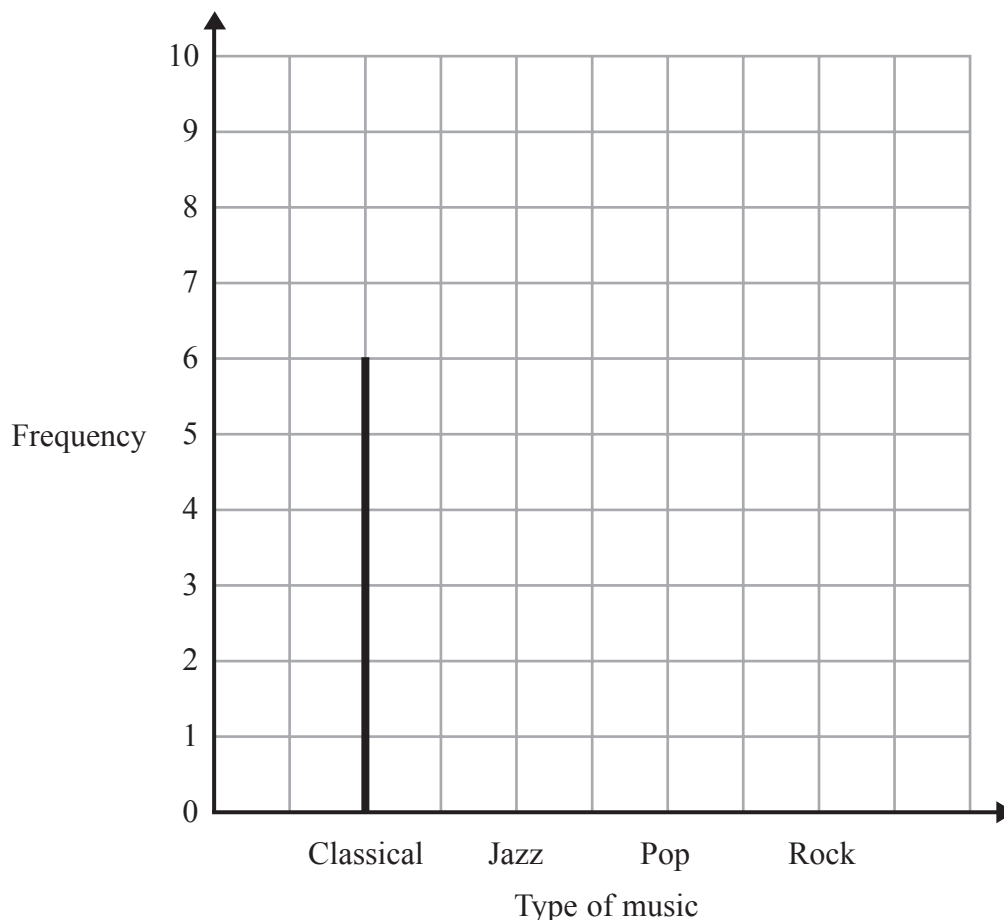

(2)

(Total for Question 2 is 5 marks)



3 Ravina is designing some spinners to use in her probability lessons.

She is going to spin each spinner once.

(a) (i) On the spinner below, write four numbers so that it is **impossible** to get a number more than 10

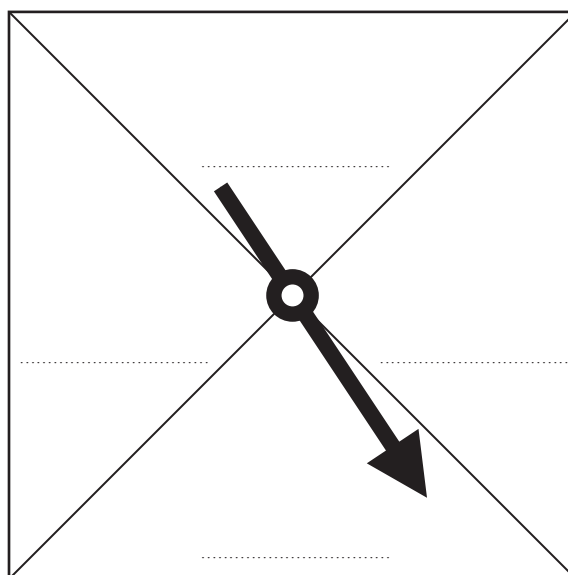

(ii) On the spinner below, write four numbers so that it is **certain** to get an odd number.

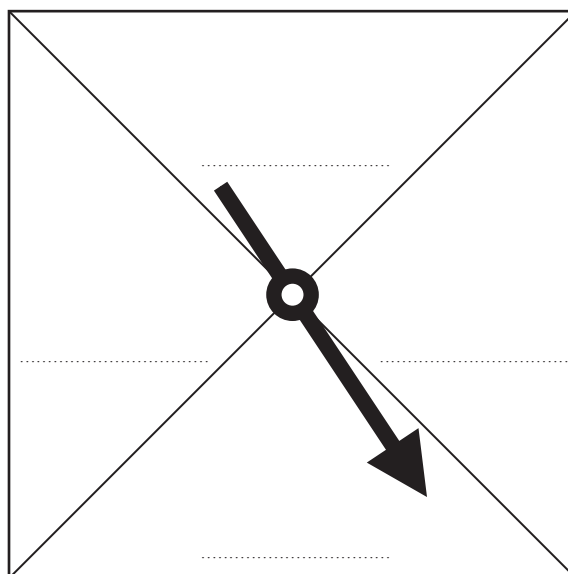

(2)

The likelihood of an outcome is **evens**.

(b) On the probability scale, mark with a cross (×) the probability of this outcome.

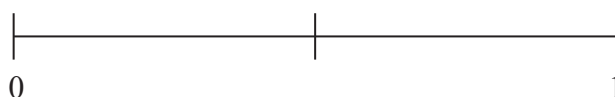

(1)

(Total for Question 3 is 3 marks)



DO NOT WRITE IN THIS AREA

DO NOT WRITE IN THIS AREA

DO NOT WRITE IN THIS AREA

4 A supermarket has a food department and a clothes department.

The two line graphs give information about the shoe sizes of the people working in each of these two departments.

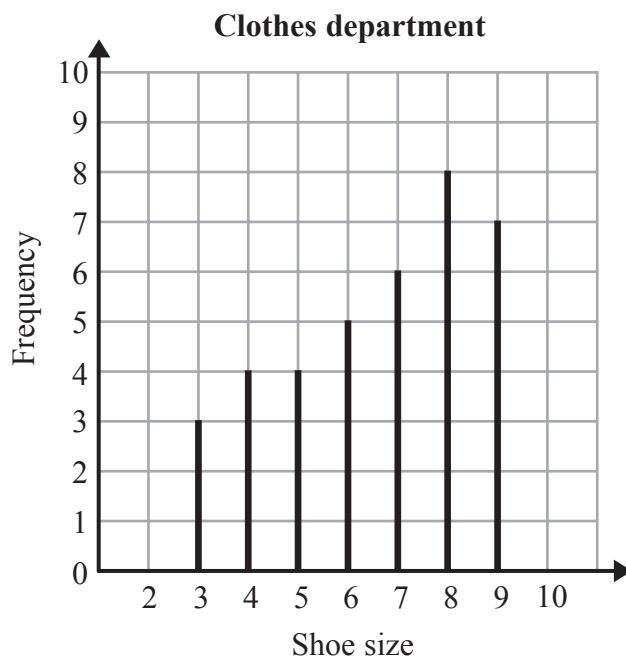
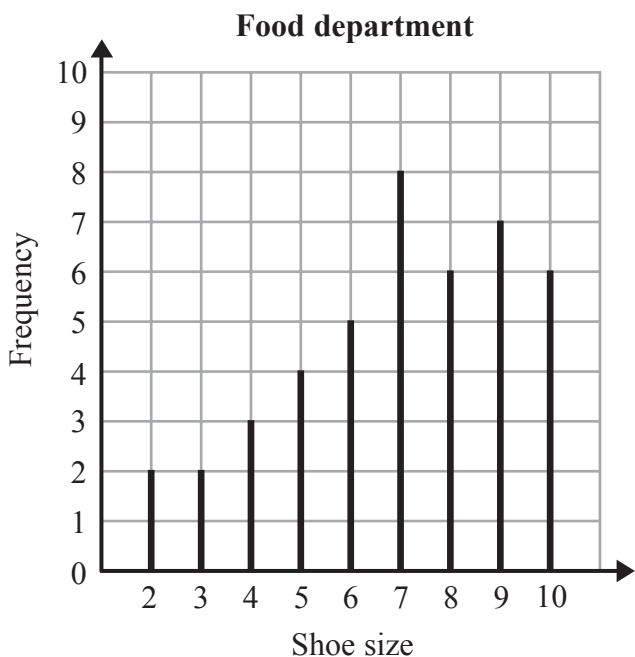

(a) What is the total number of people working in these two departments?

.....
(2)

One of these people is going to be chosen at random.

(b) Find the probability that the shoe size of this person is 4

.....
(2)

(c) Compare the modes and the ranges of the shoe sizes of the people working in the food department and in the clothes department.

Mode

Range

.....
(2)

(Total for Question 4 is 6 marks)



5 A youth club has 30 members.

The bar chart gives information about the number of members attending the youth club on each of 5 days last week.

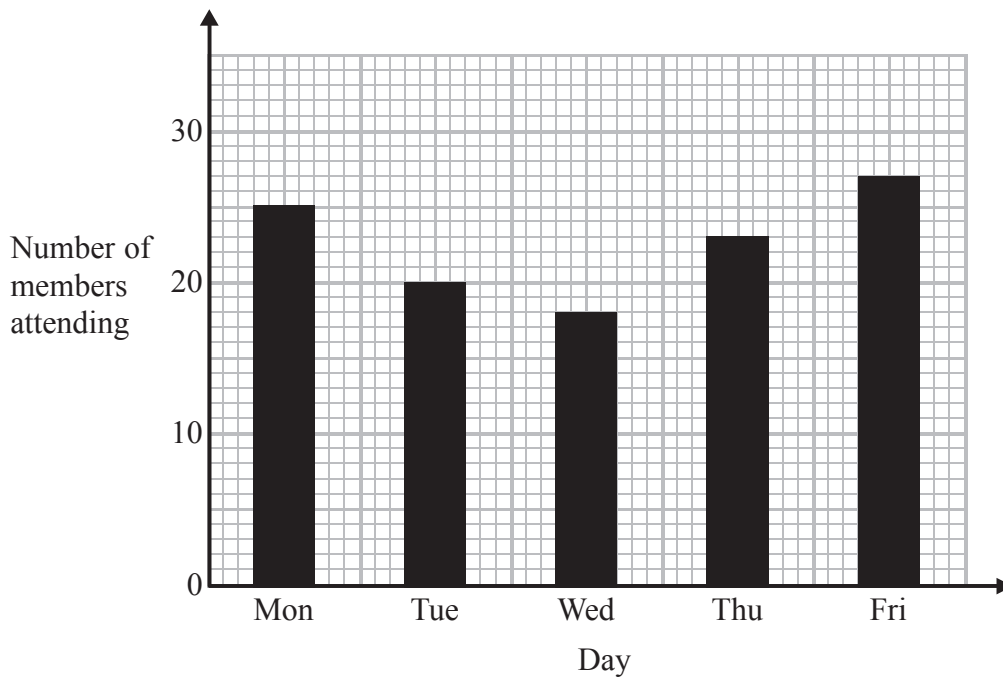

(a) How many members attended the youth club on Thursday?

.....
(1)

(b) How many members did **not** attend the youth club on Monday?

.....
(1)



DO NOT WRITE IN THIS AREA

DO NOT WRITE IN THIS AREA

DO NOT WRITE IN THIS AREA

(c) Draw a bar chart to show the number of members **not** attending the youth club on each of the 5 days last week.

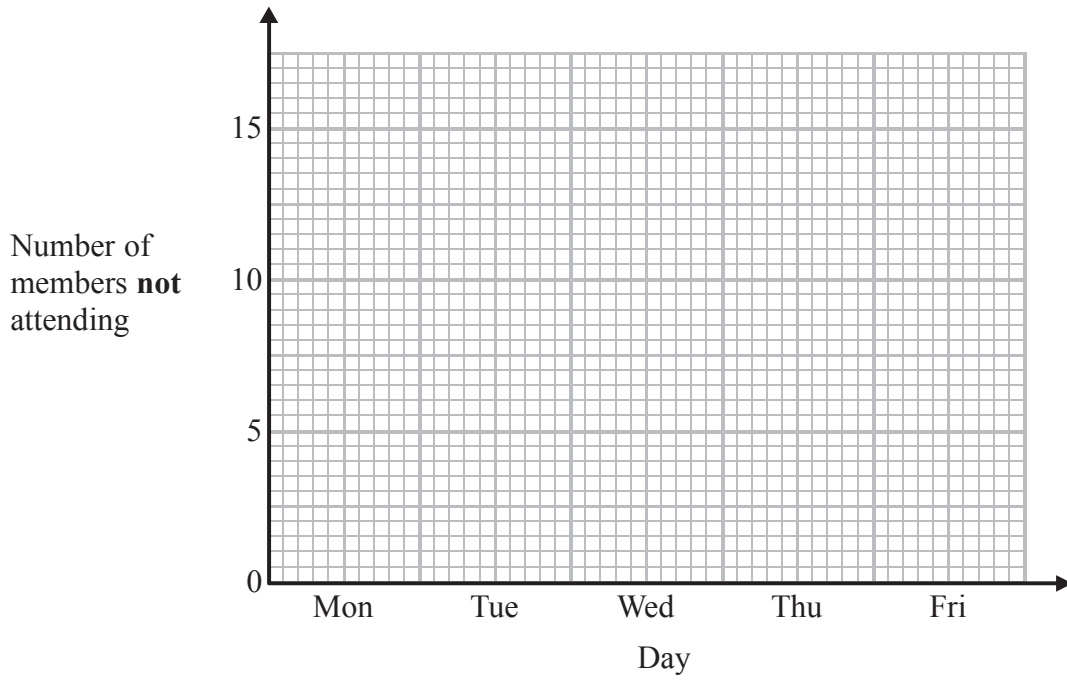

(2)

(Total for Question 5 is 4 marks)



6 The table gives information about 8 roofing tiles.

Name of roofing tile	Cover width (mm)	Thickness (mm)	Weight per m ² (kg)	Minimum pitch (°)	Length of nail (mm)
Ashmore	302	16	48	23	45
Anglia	204	30	47	31	38
Double Roman	300	28	42	25	65
Edgemere	298	18	44	22.5	45
Essex	298	29	50	15	60
Ludlow Major	295	25	45	25	55
Mendip	298	27	46	17.5	70
Modern	292	30	50	22.5	50

(a) Write down the thickness of the Modern roofing tile.

.....mm
(1)

(b) Write down the name of the roofing tile with the smallest cover width.

.....
(1)

(c) Write down the name of the roofing tile that needs the longest nail.

.....
(1)

Two of the roofing tiles have the same weight per m².

(d) Which two roofing tiles?

..... and
(1)

When an Edgemere tile is being fitted, the probability that the tile will crack is 0.04

(e) Work out the probability that the tile will **not** crack.

.....
(2)

(Total for Question 6 is 6 marks)



DO NOT WRITE IN THIS AREA

DO NOT WRITE IN THIS AREA

DO NOT WRITE IN THIS AREA

7 A company organises courses for its employees.

The two-way table gives some information about the numbers of employees who attended exactly one of these courses in 2015.

	Health & Safety	Fire Prevention	Equality & Diversity	Total
Male		29		
Female	22			63
Total	37	41		120

(a) How many of these male employees attended the fire prevention course?

.....
(1)

(b) Complete the two-way table.

(3)

A manager of the company wants to find out how many courses all of its employees attended in the last two years.

She uses this question on a questionnaire.

How many courses have you attended?

0–2 courses

2–5 courses

6–9 courses

10–16 courses

(c) Write down two things that are wrong with this question.

1

2

(2)

(Total for Question 7 is 6 marks)



8 The graph gives information about the numbers of people using the library in a village.

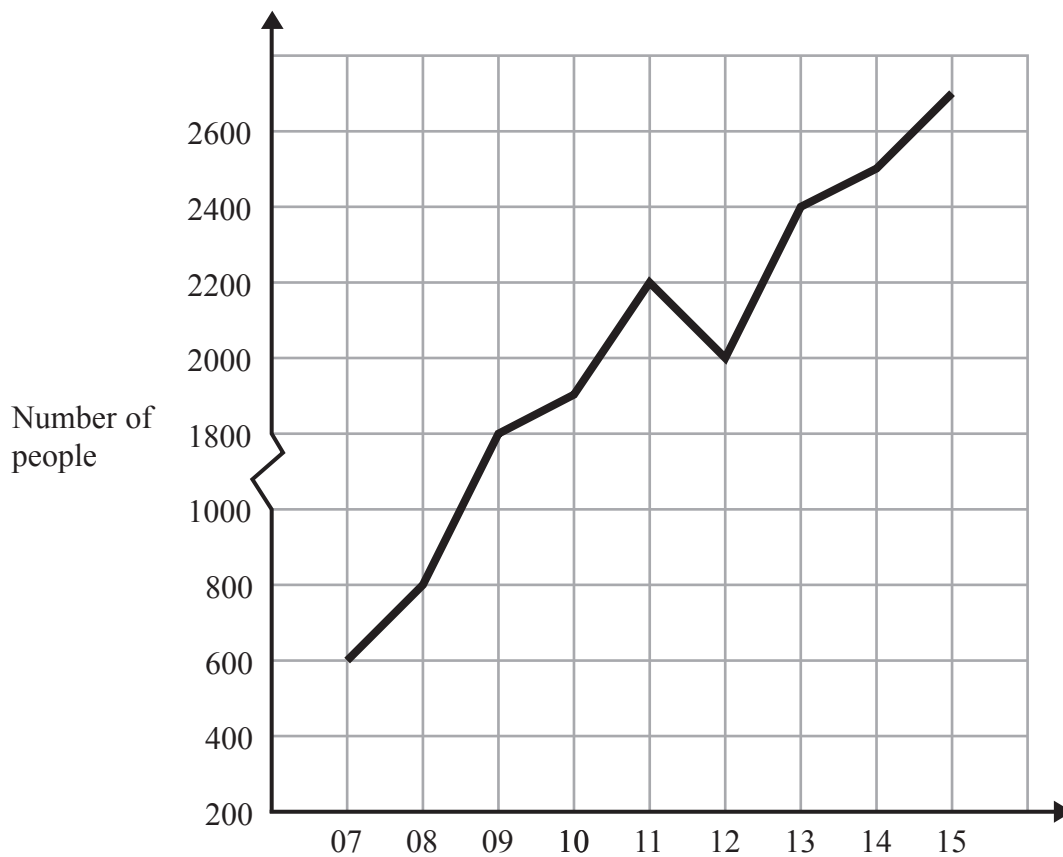

Write down three things that could be misleading or wrong with the graph.

- 1
- 2
- 3

(Total for Question 8 is 3 marks)



DO NOT WRITE IN THIS AREA

DO NOT WRITE IN THIS AREA

DO NOT WRITE IN THIS AREA

9 Karen records the number of pets in each of the families in her street.

Her results are summarised in the frequency table.

Number of pets	Frequency
0	10
1	4
2	5
3	7
4	3
5	1

(a) Write down the mode of the number of pets.

.....
(1)

One of these families is picked at random.

(b) Work out the probability that this family has **no** pets.

.....
(2)

(c) Work out the total number of pets.

.....
(2)

(Total for Question 9 is 5 marks)



10 Seb wants to hire a car.

He can choose a saloon car (S) or an estate car (E) or a convertible car (C).

He also has to choose the type of fuel needed for the car – petrol (P), diesel (D) or gas (G).

List **all** the possible combinations Seb could choose.

One has been done for you.

(S, P).....
.....
.....

(Total for Question 10 is 2 marks)

11 Alison wants to go horse riding.

A horse riding centre has 5 white horses, 6 brown horses and 8 black horses.

Alison picks at random one of these horses.

(a) Write down the probability that she picks a grey horse.

.....
(1)

(b) Work out the probability that she picks a white horse or a brown horse.

.....
(2)

(c) Work out the probability that she does **not** pick a white horse.

.....
(2)

(Total for Question 11 is 5 marks)



DO NOT WRITE IN THIS AREA

DO NOT WRITE IN THIS AREA

DO NOT WRITE IN THIS AREA

12 Suki is planning a trip to the zoo for the children in her class.
She wants to find out which animals the children want to see.
Design a data collection sheet that Suki can use to collect this information.

(Total for Question 12 is 2 marks)

13 Asha has a biased coin.
When she throws the coin she can get heads (H) or tails (T).
She throws the coin 10 times.
Here are her results.

H H H T T H H T H H

Asha throws the biased coin again.

(a) Write down an estimate for the probability that Asha gets heads.

.....
(1)

(b) Explain why this result is **not** a reliable estimate.

.....
.....
.....
(1)

(Total for Question 13 is 2 marks)



14 Avi recorded the number of extra hours worked by each person in his office.

The stem and leaf diagram gives information about the number of extra hours worked in one month by each person.

0	0 0 2 4
1	2 3 3 4 6 8
2	1 4 4 5 6 8 9
3	1 1 2 2 2 2 3
4	0 0 5 7 8

Key:
1 | 2 represents 12 hours

(a) How many people did **not** work any extra hours?

.....
(1)

(b) Write down the mode.

..... hours
(1)

(c) Work out the range.

..... hours
(2)

(Total for Question 14 is 4 marks)



DO NOT WRITE IN THIS AREA

DO NOT WRITE IN THIS AREA

DO NOT WRITE IN THIS AREA

15 A canteen serves chicken soup, tomato soup and oxtail soup.

The table shows the probabilities that a customer having soup will have chicken soup or will have tomato soup.

Soup	chicken	tomato	oxtail
Probability	0.32	0.17	

A customer having soup is picked at random.

(i) Work out the probability that this customer has chicken soup or tomato soup.

.....

(ii) Work out the probability that this customer has oxtail soup.

.....

(Total for Question 15 is 4 marks)



16 Jake measures the weights, in kg, of some parcels.

Here are his results.

4 2 7 5 4 8 11 7 5 2 7

(a) Write down the mode.

..... kg
(1)

(b) Work out the median.

..... kg
(2)

(c) Work out the mean.

..... kg
(2)

(d) Work out the range.

..... kg
(2)

(Total for Question 16 is 7 marks)



DO NOT WRITE IN THIS AREA

DO NOT WRITE IN THIS AREA

DO NOT WRITE IN THIS AREA

17 The scatter graph gives information about the lengths, in cm, and the weights, in grams, for each of 10 wires.

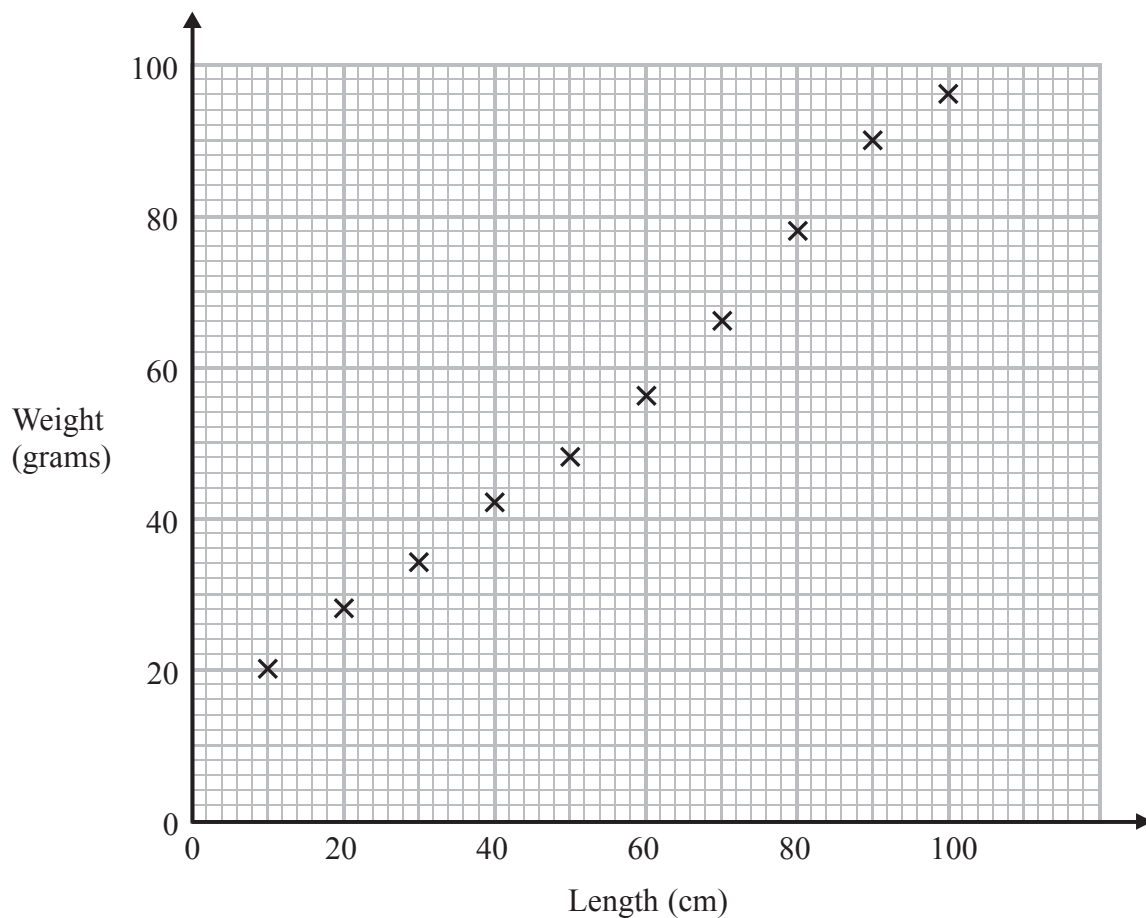

The table shows some of the results.

Length (cm)	10	20	30	40	50	60	70	80	90	100
Weights (grams)	20	28	34	42	48	56			90	96

(a) Complete the table.

(1)

(b) What type of correlation does the scatter graph show?

.....
(1)

(Total for Question 17 is 2 marks)



18 Darren records the different types of worktop he fits in kitchens in November.

The table gives information about his results.

Type of worktop	Number of worktops
Corian	18
Granite	20
Stone	30
Wood	12

(a) Complete the pie chart to show this information.

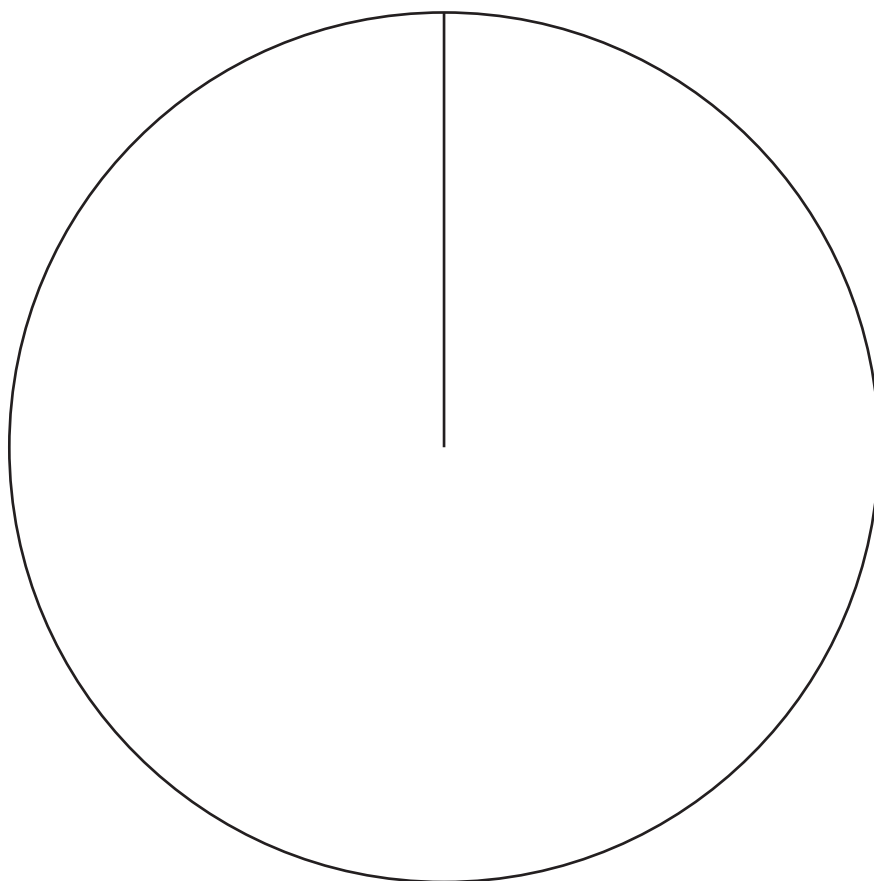

(3)

DO NOT WRITE IN THIS AREA

DO NOT WRITE IN THIS AREA

DO NOT WRITE IN THIS AREA



DO NOT WRITE IN THIS AREA

DO NOT WRITE IN THIS AREA

DO NOT WRITE IN THIS AREA

Darren estimates that he will fit a total of 60 worktops in December.

- (b) Use Darren's results for November to work out an estimate for the number of Wood worktops he will fit in December.

.....
(2)

(Total for Question 18 is 5 marks)



19 The time-series graph gives information about the number of bracelets sold in a shop each quarter for the years 2012 and 2013.

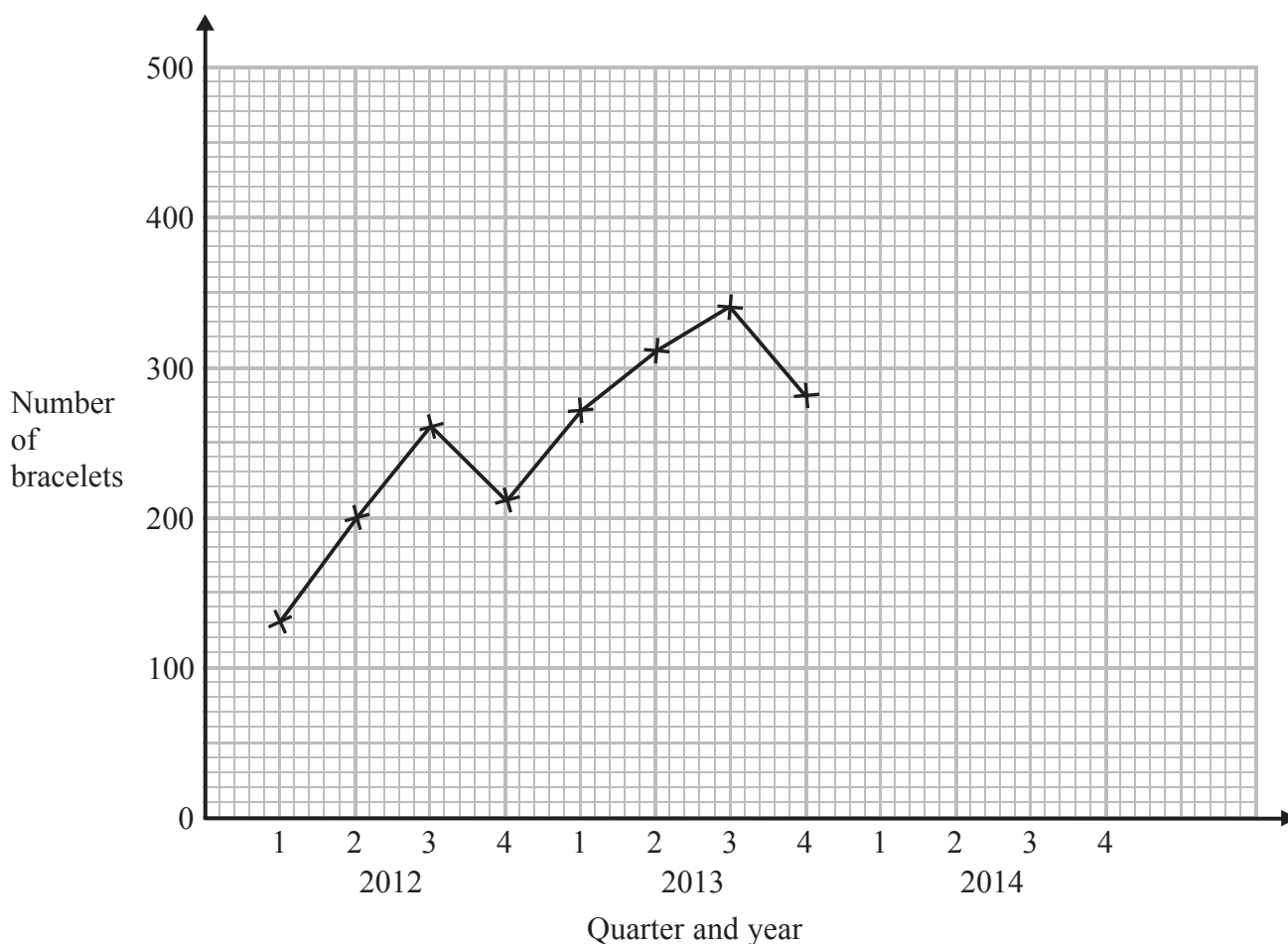

The table gives information about the numbers of bracelets sold in 2014.

	Quarter			
	1	2	3	4
2014	330	400	440	380

(a) Plot the information in the table on the time-series graph. (2)

(b) Describe the trend in the number of bracelets sold from 2012 to 2014. (1)

(c) Calculate the total number of bracelets sold in quarter 3 for the years 2012 to 2014. (2)

..... bracelets

(Total for Question 19 is 5 marks)

TOTAL FOR PAPER IS 80 MARKS

