

A close-up, slightly blurred image of a digital depth gauge with a black body and yellow accents, set against a blue background.

Getting Started

GCE Design and Technology: Product Design

Pearson Edexcel Level 3 Advanced Subsidiary GCE in Design and Technology: Product Design (8RM01/8GR01)
First certification 2014

Pearson Edexcel Level 3 Advanced GCE in Design and Technology: Product Design (9RM01/9GR01)
First certification 2014

Issue 2

Contents

Introduction **1**

Key points 1

Unit overview for Resistant Materials Technology 2

Unit overview for Graphic Products 4

Assessment overview 6

Modes of delivery **7**

Resistant Materials Technology **9**

Exemplar scheme of work 10

Integrating Unit 2 content through the delivery of Unit 1 12

External assessed units — Units 2 and 3 13

Mapping sample assessment materials (SAMs) to unit content 13

Glossary of terms 17

Internal assessed units — Units 1 and 4 19

Guidance in applying the assessment criteria 19

Breakdown of each assessment criterion 20

Unit 1: Portfolio of Creative Skills — Building a portfolio 28

Unit 1: Portfolio of Creative Skills — Exemplar student work 29

Recommended websites 35

Contents

Graphic Products	38
Exemplar scheme of work	39
Integrating Unit 2 content through the delivery of Unit 1	41
External assessed units — Units 2 and 3	42
Mapping sample assessment materials (SAMs) to unit content	42
Glossary of terms	46
Internal assessed units — Units 1 and 4	48
Guidance in applying the assessment criteria	48
Breakdown of each assessment criterion	49
Unit 1: Portfolio of Creative Skills — Building a portfolio	57
Unit 1: Portfolio of Creative Skills — Exemplar student work	58
Recommended websites	64



Introduction

The Edexcel GCE in Design and Technology: Product Design has been developed in consultation with schools, colleges, higher education institutes, to engage students and teachers.

This document will give you an overview of the course. The guidance in this book is intended to help you plan the course and to give you further insight into the principles behind the content, to help you and your students succeed in the course.

Key points

- A four-unit structure
- Two pathways within Product Design — Resistant Materials Technology and Graphic Products
- Internal units weighted at 60 per cent
- Clear assessment criteria for the internal assessed units — Units 1 and 4
- Guidance on each assessment criterion in Units 1 and 4
- Focused tasks in Unit 1
- Encourages creative and innovative approach to the internal assessed units
- Clearly defined content in the external assessed units — Units 2 and 3

Unit overview for Resistant Materials Technology

The unit overviews give a summary of the content of each unit so that you can organise your teaching effectively.

Unit 1: Portfolio of Creative Skills (Internal assessment)	
Sections:	Sub-sections:
Product investigation	Performance analysis Materials and/or components Manufacture Quality
Product design	Design and development Communicate
Product manufacture	Production plan Making Testing

Unit 2: Design and Technology in Practice (External assessment)	
Sections:	Sub-sections:
Materials and components	Materials: Metals Polymers Woods Composites Laminates Modern materials and products New and smart materials
Industrial and commercial practice	Components
Industrial and commercial practice	Scale of production Material processing and forming techniques Manufacturing techniques for mass production Joining techniques Material removal Heat treatment Conversion and seasoning Faults in woods Computer-aided design (CAD) Modelling and prototyping Computer-aided manufacture
Quality	Quality assurance systems and quality control in production Quality standards
Health and safety	Health and Safety at Work Act (1974)

Unit 3: Designing for the Future (External assessment)	
Sections:	Sub-sections:
Industrial and commercial practice	Information and communication technology (ICT) Biotechnology
Systems and control	Manufacturing systems Computer integrated manufacture (CIM) Robotics and Artificial Intelligence (AI) Flow charts
Design in context	The effects of technological changes on society Influences of design history on the development of products Form and function Anthropometrics and ergonomics
Sustainability	Life cycle assessment (LCA) Cleaner design and technology Minimising waste production Renewable and non-renewable sources of energy Responsibilities of developed countries

Unit 4: Commercial Design (Internal assessment)	
Sections:	Sub-sections:
Product design and make	Research and analysis
	Product specification
	Design and development: Design Review Develop Communicate
	Planning
	Making: Use of tools and equipment Quality Complexity/level of demand
	Testing and evaluating

Unit overview for Graphic Products

The unit overviews give a summary of the content of each unit so that you can organise your teaching effectively.

Unit 1: Portfolio of Creative Skills	
Sections:	Sub-sections:
Product investigation	Performance analysis Materials and/or components Manufacture Quality
Product design	Design and development Communicate
Product manufacture	Production plan Making Testing

Unit 2: Design and Technology in Practice	
Sections:	Sub-sections:
Materials and components	Materials: Paper and board Metals Polymers Woods Composites Modern materials and products Smart materials
	Components
Industrial and commercial practice	Scale of production Graphical communication Computer-generated graphics Modelling and prototyping Joining techniques Industrial and commercial processes Forming techniques Finishing processes Printing processes
Quality	Quality assurance systems and quality control in production Quality standards
Health and safety	Health and Safety at Work Act (1974)

Unit 3: Designing for the Future	
Sections:	Sub-sections:
Industrial and commercial practice	Information and communication technology (ICT) Digital special effects Biotechnology
Systems and control	Manufacturing systems Computer integrated manufacture (CIM) Robotics and Artificial Intelligence (AI) Flow charts
Design in context	The effects of technological changes on society Influences of design history on the development of products Form and function Anthropometrics and ergonomics
Sustainability	Life cycle assessment (LCA) Cleaner design and technology Minimising waste production Renewable and non-renewable sources of energy Responsibilities of developed countries

Unit 4: Commercial Design	
Sections:	Sub-sections:
Product design and make	Research and analysis
	Product specification
	Design and development: Design Review Develop Communicate
	Planning
	Making: Use of tools and equipment Quality Complexity/ level of demand
	Testing and evaluating

Assessment overview

The course will be assessed by both externally set examinations and internal assessment. Detailed information on each unit can be found later in the document.

AS units

Unit 1: Portfolio of Creative Skills	Unit 2: Design and Technology in Practice
<p>Internal assessment Internally set and marked by the centre and externally moderated by Edexcel.</p> <p>Number of marks: 90 Students produce one portfolio that contains evidence of product investigation, product design and product manufacture. Photographic evidence must be supplied for the product(s) they have made.</p>	<p>External assessment Time: 1 hour 30 minute examination set and marked by Edexcel.</p> <p>Number of marks: 70 Style of paper: Question and answer booklet, consisting of short-answer and extended-writing type questions.</p>

A2 units

Unit 3: Designing for the Future	Unit 4: Commercial Design
<p>External assessment Time: 2-hour examination set and marked by Edexcel.</p> <p>Number of marks: 70 Style of paper: Question and answer booklet, consisting of short-answer and extended-writing type questions.</p>	<p>Internal assessment Internally set and marked by the centre and externally moderated by Edexcel.</p> <p>Number of marks: 90 Students design and make a product. This is evidenced in their design folder with photographic evidence of them making the product and of the final product itself.</p>

Modes of delivery

Advanced Subsidiary GCE — Year 12

Term 1		Term 2		Half-term 5
Half-term 1	Half-term 2	Half-term 3	Half-term 4	
Unit 2: Design and Technology in Practice	Unit 1: Portfolio of Creative Skills — Product investigation	Unit 1: Portfolio of Creative Skills — Product design	Unit 1: Portfolio of Creative Skills — Product manufacture	Revision and examination preparation

OR

Terms 1 and 2			Half-term 5
Unit 2: Design and Technology in Practice			Revision and examination preparation
Unit 1: Portfolio of Creative Skills — Product investigation	Unit 1: Portfolio of Creative Skills — Product design	Unit 1: Portfolio of Creative Skills — Product manufacture	

OR

Terms 1 and 2		Half-term 5
Unit 2: Design and Technology in Practice		Revision and examination preparation
Unit 1: Portfolio of Creative Skills — Product investigation	Unit 1: Portfolio of Creative Skills — Product manufacture	
Unit 1: Portfolio of Creative Skills — Product design		

OR

Terms 1 and 2		Half-term 5
Unit 2: Design and Technology in Practice		Revision and examination preparation
Unit 1: Portfolio of Creative Skills — Product investigation		
Unit 1: Portfolio of Creative Skills — Product design		
Unit 1: Portfolio of Creative Skills — Product manufacture		

The tables above are examples of how the AS course might be delivered over a period of five half-terms. Centres are encouraged to teach students in the most effective way, taking account of their teaching styles, strengths and resources.

The illustrations above are suggestions, but a recommendation would be that whichever mode of delivery is adopted, it should include some elements of parallel delivery. This includes the theory unit, *Unit 2: Design and Technology in Practice*, so that knowledge and understanding of materials, components, processes and techniques is always current and relevant to students' tasks.

Advanced Level GCE – Year 13

Terms 1 and 2	Half-term 5
Unit 3: Designing for the Future	Revision and examination preparation
Unit 4: Commercial Design	

Resistant Materials Technology

Exemplar scheme of work	10
Integrating Unit 2 content through the delivery of Unit 1	12
External assessed units — Units 2 and 3	13
• Mapping sample assessment materials (SAMs) to unit content	13
• Glossary of terms	17
Internal assessed units — Units 1 and 4	19
• Guidance in applying the assessment criteria	19
• Breakdown of each assessment criterion	20
• Unit 1: Portfolio of Creative Skills — Building a portfolio	28
• Unit 1: Portfolio of Creative Skills — Exemplar student work	29
Recommended websites	35

Exemplar scheme of work

Unit 1: Portfolio of Creative Skills – Product investigation

Outline scheme of work

In this example the teacher leads the exercise and all students are to investigate the same product – a digital camera. This will act as the basic template for students when they study a product of their own choice later on in the term. Additionally, this will give each student two complete product investigations, the better of the two will be submitted for assessment in their final portfolio.

NB: The camera in this example would be available for complete disassembly and would not be required for use again.

This outline scheme of work is based on a five-hours-per-week timetable allocation over a period of five weeks.

WEEK 1	<p>Product study task To study the digital camera in detail, using a series of photographs and taking precise measurements to produce:</p> <ul style="list-style-type: none"> a an accurate scaled and dimensioned drawing in orthographic projection of the digital camera b accurate assembly drawings of selected camera component parts, drawn to scale and dimensioned, using pictorial techniques, eg isometric, oblique, axonometric, perspective, exploded. <p>(Could be undertaken using 2D/3D CAD packages, eg 2D Design, ProDesktop, Solid Edge.)</p> <p>Independent study time Task: To fully label all drawn components and add appropriate annotation, component list to drawings.</p>
WEEK 2	<p>Performance analysis task</p> <ul style="list-style-type: none"> a To produce a technical specification for the digital camera, including: <ul style="list-style-type: none"> i Form — why is the camera shaped/styled as it is? ii Function — what is the purpose of the digital camera? iii User requirements — what qualities make the digital camera attractive to potential users? iv Performance requirements — what are the technical considerations that must be achieved by the digital camera? v Material and component requirements — how should materials and components perform within the digital camera? vi Scale of production and cost — how does the design allow for scale of production and what are the considerations in determining cost? b To analyse another digital camera using the same criteria and compare and contrast it with the one studied in class. <p>Independent study time Task: To identify the materials and components used in the digital camera.</p>

**WEEK 3****Materials and components task**

Using the range of orthographic and pictorial drawings produced in Week 1 students:

- a evaluate the use of the materials and components identified in the manufacture of the digital camera
- b investigate suitable alternative materials in terms of quality and performance. Evaluate alternative materials in comparison to those actually used.

Independent study time

Task: To research the potential environmental impact of material extraction and modern manufacturing processes.

WEEK 4**Materials and components task (continued)**

c explain the environmental effects of using the materials identified in the manufacture of the digital camera in relation to:

- extraction and processing of raw materials
- production processes
- disposal of products after their useful lifespan.

Manufacture task

Using the range of orthographic and pictorial drawings produced in Week 1:

- a identify and describe the range of processes involved in the manufacture of the digital camera and its component parts
- b evaluate the use of the processes selected.

Independent study time

Task: To complete parts a and b of the manufacture task.

WEEK 5**Manufacture task (continued)**

c identify **one** alternative method of manufacturing some parts of the digital camera and compare and contrast it with the methods actually used.

d describe the effects that the processes used to manufacture the digital camera have on the environment.

Quality task

Using the processes identified in the manufacture of the digital camera:

- a identify and describe the range of quality control (QC) checks that have taken place during the manufacture of the digital camera
- b describe the quality assurance (QA) system for the manufacture and after-sales service of the product
- c identify and describe some of the main standards that must be met during product manufacture and how they influence production and the final product.

Independent study time

Task: To complete all outstanding work in preparation for assessment.

Integrating Unit 2 content through the delivery of Unit 1

Example: Product investigation of a digital camera.

Assessment criteria	High level of response	Appropriate Unit 2 content
A. Performance analysis	Fully justify key technical specification points that relate to form, function, user requirements, performance requirements, materials and/or component requirements, scale of production and costs. Compare and contrast one other existing similar product using the technical specification.	<p>Materials and components Properties, application, advantages/disadvantages of metals, polymers, composites, modern materials and products, nuts, bolts, spacers, washers, screws, for camera case. Basic knowledge of surface mount technology for printed circuit board production (not in specification).</p> <p>Industrial and commercial practice Characteristics, application and advantages/disadvantages of mass production and associated techniques. Characteristics, preparation, processes, application and advantages/disadvantages of thermoforming techniques. Characteristics, preparation, processes, application and advantages/disadvantages of joining using mechanical, chemical and adhesive techniques.</p>
B. Materials and components	Suggest, with reference to quality and performance, alternative materials and/or components that could have been used in the product. Evaluate, using advantages and disadvantages, the selection of the materials and/or components used. Describe the impact on the environment of using the materials and/or components identified.	<p>Materials and components Properties, application, advantages/disadvantages of metals, polymers, composites, modern materials and products, nuts, bolts, spacers, washers, screws, for camera case. Properties, application, advantages/disadvantages of metals or polymers for the camera.</p>
C. Manufacture	Evaluate, using advantages and disadvantages, the selection of the manufacturing processes used in the product. Suggest one alternative method of production that could have been used in the manufacture of the product. Describe the impact on the environment of using the processes identified in the production of the product.	<p>Industrial and commercial practice Characteristics, preparation, processes, application and advantages/disadvantages of thermoforming techniques for the camera case and component parts. Characteristics, preparation, processes, application and advantages/disadvantages of die casting for the camera case and component parts. Processes, applications, production and advantages/disadvantages of computer-aided manufacture.</p>
D. Quality	Describe a range of quality control checks used during the manufacture of the product and explain how the main relevant standards influenced the manufacture of the product. Describe a quality assurance (QA) system for the product.	<p>Quality Concept, characteristics, application and advantages of QA, QC and TQM when manufacturing the digital camera. Meeting specifications and tolerances. Process of testing products, components and materials against external quality standards set by relevant organisations.</p>



External assessed units — Units 2 and 3

Mapping sample assessment materials (SAMs) to unit content

The following section shows how each question in the SAMs for these units were mapped against the specification unit content.

Unit 2: Design and Technology in Practice

Question 1	Clarification	Content
(a)(i) and (ii)	A straightforward question about the advantages and disadvantages of hardwoods and softwoods. Designed to ease candidates into the paper.	Materials and components — Materials c) Woods
(b)	A straightforward question which asks candidates to identify potential hazards when manufacturing park benches and asks them to identify how each associated risk could be minimised. This is an important aspect of all practical work.	Health and safety — Health and Safety at Work Act (1974)
Question 2	Clarification	Content
(a) and (b)	Both parts of the question require candidates to apply their knowledge and understanding of the basic differences between thermo and thermosetting plastics in terms of their: <ol style="list-style-type: none"> 1 structural composition — using sketches and or notes 2 how they behave when heated. 	Materials and components — Materials b) Polymers
(c)(i) and (ii)	The first part of the question tests students' knowledge and understanding of the way metals behave when worked and the second part tests how the working properties can be improved using heat treatment.	Industrial and commercial practice — Heat treatment
Question 3	Clarification	Content
(a)	Candidates must be familiar with the advantages and disadvantages of using these types of machines for various applications. The increased rigour in this question is based on needing to know four advantages.	Industrial and commercial practice — Computer-aided manufacture
(b)(i) and (ii)	The first part of the question directly addresses an understanding of the concept of quality assurance, whilst the second part requires candidates to explain how it is applied.	Quality — Quality assurance systems and quality control in production
Question 4	Clarification	Content
(a)	Candidates need to recognise the functional and mechanical properties of cast iron. The product chosen is used to focus candidate's responses.	Materials and components — Materials a) Metals
(b)	Candidates are to be familiar with the need to monitor and inspect products in varying quantities. The volume production of the chosen product guides candidates towards the advantages of using computer aided inspection.	Quality — Quality assurance systems and quality control in production

Question 5	Clarification	Content
(a) and (b)	The first part is a more in-depth question which requires candidates to compare a laminate with another material. The second part requires that candidates know the structural composition of a material.	Materials and components — Materials e) Laminates
(c)	This question requires that candidates know the characteristics and application of the chosen components and are able to apply them to a given situation. The question allows candidates to choose their method of explanation.	Materials and components — Components
Question 6	Clarification	Content
(a) and (b)	A relatively easy lead in to the question which requires candidates to link a material characteristic with its application. The second part of the question requires candidates to show an in-depth knowledge of how products are manufactured from a composite.	Materials and components — Materials d) Composites
(c)	This question requires that candidates know the characteristics of batch production and apply its advantages to the manufacture of the given product.	Industrial and commercial practice — Scale of production
Question 7	Clarification	Content
(a) and (b)	This question appears at the end of the paper and is intended to stretch and challenge. Candidates should have studied the process of extrusion and: 1 be familiar with the process 2 be able to explain why its characteristics are suited to applications.	Industrial and commercial practice — Material processing and forming techniques

NB: Please note that questions cover the four sections of this unit. No paper will ever focus entirely on one section. It is also anticipated that consecutive years will address different parts of the unit content to give full unit coverage. Therefore, it is important that students are familiar with the content for the whole unit and are given plenty of opportunities to answer examination style questions throughout the course to prepare them for the final examination.

Unit 3: Designing for the Future

Question 1	Clarification	Content
(a)(i) and (ii)	A straight forward question on the advantages and disadvantages of electronic communication. Designed to ease the candidates into the paper.	Industrial and commercial practice — Information and communication technology (ICT)
(b)	This question requires that candidates know and understand CIM and are able to relate it to production levels. They must be able to give reasons and justify them.	Systems and control — Computer integrated manufacture (CIM)
Question 2	Clarification	Content
(a)	Candidates are asked to link how recycling used plastics can have a positive effect on the environment.	Sustainability — Cleaner design and technology
(b)	Candidates are asked to relate their knowledge of complex manufacturing techniques to the problem of keeping waste to a minimum.	Systems and control — Computer integrated manufacture (CIM)
(c)	Candidates need to be able to convey their knowledge and understanding of sustainable development in relation to how a designer must consider it when designing.	Sustainability — Cleaner design and technology
Question 3	Clarification	Content
(a)	A lead in to the question in which candidates need to demonstrate a benefit of using Biopol®.	Industrial and commercial practice — Biotechnology
(b)(i) and (ii)	Candidates are asked to show their knowledge and understanding of various forms of fuel and to express this as both advantages and disadvantages.	Sustainability — Renewable and non-renewable sources of energy
Question 4	Clarification	Content
(a)	Candidates are asked to apply their knowledge and understanding of the principles of built-in obsolescence in terms of advantages for the manufacturer.	Design in context — The effects of technological changes on society
(b)(i) and (ii)	Candidates are asked to demonstrate their knowledge and understanding of how industrial mass production affects society.	Design in context — The effects of technological changes on society
Question 5	Clarification	Content
(a)	This question requires that candidates know and understand the advantages of JIT as a business strategy.	Systems and control — Computer integrated manufacture (CIM)
(b)	Candidates need to show understanding and knowledge of the characteristics of FMS and relate them to their implementation in terms of advantages and disadvantages.	Systems and control — Manufacturing systems
Question 6	Clarification	Content
(a)(i) and (ii)	Candidates need to demonstrate that they understand the reasons why these additives are used.	Industrial and commercial practice — Biotechnology
(b)	Candidates are asked to apply their knowledge and understanding of how genetic engineering can impact on timber production.	Industrial and commercial practice — Biotechnology
Question 7	Clarification	Content
	This is a new style question which uses two products as a vehicle for candidates to demonstrate their knowledge and understanding of form versus function. It is the last question and, as such, is less structured and designed to stretch and challenge candidates.	Design in context — Form and function

NB: Please note that questions cover the four sections of this unit. No paper will ever focus entirely on one section. It is also anticipated that consecutive years will address different parts of the unit content to give full unit coverage. Therefore, it is important that students are familiar with the content for the whole unit and are given plenty of opportunities to answer examination style questions throughout the course to prepare them for the final examination.



Glossary of terms

Unit 2: Design and Technology in Practice

Each section in the unit content carries a 'stem' explaining what students specifically need to learn for this examination.

For example:

b) Polymers

Aesthetic, functional and mechanical properties, structural composition with reference to cross linking, application and advantages/disadvantages of the following polymers when manufacturing products:

(followed by the list of specific polymers)

Students need to be familiar with the specific properties of the polymers listed, where they are best used and why. The stem is further clarified by the use of polymers in resistant material products.

The following are the main terms used in this unit.

Key term in section stem	Meaning
Aesthetic properties	The visual qualities of materials.
Functional properties	The qualities a material must possess in order to be fit for purpose, eg the correct weight, grade, size.
Mechanical properties	The material's reaction to physical forces, eg strength, plasticity, ductility, hardness, brittleness, malleability.
Application	The quality of being usable for a particular purpose or in a special way; relevance.
Advantages/disadvantages	Qualities and features favourable to success or failure.
Processes	A description of the systematic series of actions needed to produce something.
Structural composition	How a material is made up.
Characteristics	Recognisable features that help to identify or differentiate one process from another.
Preparation	Action required before a process can begin.
Production/manufacture	The process of manufacture.
Concept	The general idea behind the use of quality assurance systems.
Principles	The distinct reasons for health and safety legislation.

Unit 3: Designing for the Future

Each section in the unit content carries a 'stem' explaining what students specifically need to learn for this examination.

For example:

Computer integrated manufacture (CIM)

Characteristics, processes, application, advantages/disadvantages and its impact on employment of CIM systems to integrate the processing of production and business information with manufacturing operations, including:

(followed by a list of characteristics of CIM systems)

Students have to study a wide range of aspects relating to the use of CIM systems. Firstly, students need to develop an in-depth knowledge and understanding of the features of CIM systems and how they are used to produce products. Then, they must explain the advantages and disadvantages of using CIM systems, in particular their effect on the modern workforce.

The following are the main terms used in this unit.

Key term in section stem	Meaning
Application	The quality of being usable for a particular purpose or in a special way; relevance.
Advantages/disadvantages	Qualities and features favourable to success or failure.
Processes	A description of the systematic series of actions in order to produce something.
Characteristics	Recognisable features that help to identify or differentiate one process from another.
Production	The process of manufacture.
Principles	The distinct reasons for something.
Impact	Effects felt as a result of man's intervention/modern systems.
Sources	Raw materials for processing.
Debate	Discussion involving opposing viewpoints.
Responsibilities	The duty and obligations of developed countries.



Internal assessed units — Units 1 and 4

Guidance in applying the assessment criteria

The following points may help when establishing a final mark for the student's work:

- read through the student's work to form an overall impression of the level of response achieved
- study the evidence presented by the student for each assessment criterion
- read the level of response descriptors for each assessment criterion and identify the group of statements that offer the 'best fit' for a student's work
- match the evidence presented and the individual statements available to further refine the range of marks, eg 7-12, to establish a final score within that range.

Where 'best fit' bridges two levels of response, eg medium and high, and where perhaps two level statements from the high level are met and the rest firmly within the medium level, it would be acceptable to place the overall level of response within the bottom one or two marks of the high level of response category. More statements met from the high level category would earn further credit in that section.

Similarly, if the majority of statements in the medium level of response category were met, but one or two were in the low level of response category, the likely overall mark would be at the low end of the medium level category. More statements judged to be in the low level of response category would lower the overall mark accordingly.

This type of refinement is more likely to be necessary where a substantial range of marks is available at each level of response. The maximum mark range in any group of level descriptors is six.

In Unit 1 — Product manufacture, where students have produced more than one piece of work and each piece focuses on particular skills using specific materials, assessment should be carried out as a holistic exercise, taking into account the range of work produced and the levels of response achieved overall.

Assessment of 'best fit' should be established, but the highest levels of achievement in each assessment category are likely to be derived from different making exercises. Where this is the case, the evidence used to award marks must be clearly photographed and submitted for external moderation.

Breakdown of each assessment criterion

Each assessment criterion has a range of marks. The following tables show how those marks are broken down.

When marking students work, this will help you to determine the final mark to award them for each criterion.

This should be used in conjunction with the information on *Guidance in applying the assessment criteria*.

Unit 1: Portfolio of Creative Skills

Product investigation

Assessment criteria: A. Performance analysis

Level of response	Mark range
Fully justify key technical specification points <ul style="list-style-type: none"> • that relate to form, function, user requirements, performance requirements, materials and/or component requirements, scale of production and costs. Compare and contrast one other existing similar product using the technical specification.	4-6
Identify <ul style="list-style-type: none"> • with some justification • a range of realistic and relevant specification points that include reference to form, function and user requirements. 	1-3

Assessment criteria: B. Materials and components

Level of response	Mark range
Suggest, with reference to quality and performance, alternative materials and/or components that could have been used in the product. Evaluate, using advantages and disadvantages, the selection of the materials and/or components used. Describe the impact on the environment of using the materials and/or components identified.	7-9
Describe a range of useful properties that relate to the materials and/or components identified and <ul style="list-style-type: none"> • justify their selection and use in the product. Identify alternative materials and/or components that could have been used in the product.	4-6
Identify a material or component used in the product. Describe a useful property of that material or component <ul style="list-style-type: none"> • and justify its use. 	1-3



Assessment criteria: C. Manufacture

Level of response	Mark range
Evaluate, using advantages and disadvantages, the selection of the manufacturing processes used in the product. Suggest one alternative method of production that could have been used in the manufacture of the product. Describe the impact on the environment of using the processes identified in the production of the product.	7-9
Describe <ul style="list-style-type: none"> • a range of processes used in the manufacture of the product • and fully justify their use for the level of production of the product. 	4-6
Identify, <ul style="list-style-type: none"> • describe • and justify the use of a manufacturing process used in the construction of the product. 	1-3

Assessment criteria: D. Quality

Level of response	Mark range
Describe a range of quality control checks used during the manufacture of the product <ul style="list-style-type: none"> • and explain how the main relevant standards influenced the manufacture of the product. Describe a quality assurance (QA) system for the product.	4-6
Identify, <ul style="list-style-type: none"> • describe • and justify the use of one quality control check during the manufacture of the product. 	1-3

Product design

Assessment criteria: E. Design and development

Level of response	Mark range
<p>Present alternative ideas that are workable, realistic and detailed and which fully address the design criteria. Ideas demonstrate detailed understanding of materials, processes and techniques.</p> <p>Produce a final design proposal that is significantly different and improved compared to any previous alternative design ideas.</p> <p>The design proposal includes technical details of materials and components, processes and techniques. Modelling through the use of traditional materials or 2D and/or 3D computer simulations is used to test important aspects of the final design proposal.</p> <p>The final design proposal is evaluated objectively against the design criteria in order to fully justify the design decisions taken.</p>	13-18
<p>Present realistic alternative design ideas. Ideas are detailed and address most design criteria.</p> <p>Developments are appropriate and use details from ideas to change, refine and improve the final design proposal.</p> <p>A final detailed design proposal is presented.</p> <p>Modelling is used to test some aspects of the final proposal against relevant design criteria.</p> <p>Evaluative comments objectively consider some aspects of the design brief/need.</p>	7-12
<p>Present simplistic alternative design ideas. Ideas are superficial and address limited design criteria.</p> <p>Developments are minor and cosmetic.</p> <p>A basic final design proposal is presented.</p> <p>Basic modelling is used to test an aspect of the design proposal.</p> <p>Evaluative comments are subjective and superficial.</p>	1-6

Assessment criteria: F. Communicate

Level of response	Mark range
<p>Use a range of communication techniques and media including ICT and CAD,</p> <ul style="list-style-type: none"> • with precision and accuracy • to convey enough detailed and comprehensive information to enable third-party manufacture of the final design proposal. <p>Annotation provides explanation and most technical details of materials and processes with justification.</p>	9-12
<p>Use a range of communication techniques, including ICT</p> <ul style="list-style-type: none"> • that are carried out with sufficient skill • to convey an understanding of design and develop intentions and construction details of the final design proposal. <p>Annotation provides explanation and most technical details of materials and process selection.</p>	5-8
<p>Use a limited range of communication techniques</p> <ul style="list-style-type: none"> • carried out with enough skill • to convey some understanding of design and develop intentions. <p>Annotation provides limited technical details of materials and processes.</p>	1-4



Product manufacture

Assessment criteria: G. Production plan

Level of response	Mark range
Produce a detailed production plan <ul style="list-style-type: none"> • that considers stages of production in the correct sequence, • realistic time scales and deadlines for the scale of production. 	4-6
Produce a limited production plan <ul style="list-style-type: none"> • that considers the main stages of manufacture, • reference to time and scale of production. 	1-3

Assessment criteria: H. Making

Level of response	Mark range
Demonstrate a detailed understanding and justified selection of a range of <ul style="list-style-type: none"> • appropriate materials • and processes. Demonstrate demanding and high quality making skills and techniques. Show accuracy and precision when working with a variety of materials, processes and techniques. High-level safety awareness is evident throughout all aspects of manufacture.	13-18
Demonstrate a good understanding and selection of an appropriate range <ul style="list-style-type: none"> • of materials • and processes. Demonstrate competent making skills and techniques appropriate to a variety of materials and processes. Show attention to detail and some precision. Demonstrate an awareness of safe working practices for most specific skills and processes.	7-12
Demonstrate a limited understanding and selection of a narrow range <ul style="list-style-type: none"> • of materials • and processes. Use limited making skills and techniques. Demonstrate little attention to detail. Demonstrate an awareness of specific safe working practices during product manufacture.	1-6

Assessment criteria: I. Testing

Level of response	Mark range
Describe and justify a range of tests carried out to check the performance or quality of the product(s). Relevant, measurable points of the design brief(s)/need(s) are objectively referenced. Third-party testing is used.	4-6
Carry out one or more simple tests to check the performance or quality of the final product(s). Some points of the design brief(s)/need(s) are referenced superficially. Test results are recorded and are subjective.	1-3

TOTAL NUMBER OF MARKS AVAILABLE	90
--	-----------

Unit 4: Commercial Design — Assessment criteria

A. Research and analysis

Level of response	Mark range
Analysis is detailed with most design needs clarified. Research is selective and focuses on the needs identified in the analysis.	3-4
Analysis is limited with some design needs clarified. Research is superficial and does not focus on the needs identified in the analysis.	1-2

B. Product specification

Level of response	Mark range
Specification points are realistic, technical and measurable. Specification fully justifies points developed from research in consultation with a client/user-group. Sustainability of resources is realistically considered and relevant when developing specification points.	4-6
Specification points are realistic but not measurable. Some specification points are developed from research in limited consultation with a client/user-group, but are not justified. Sustainability of resources is considered superficially when developing specification points.	1-3

C. Design and development — Design

Level of response	Mark range
Present alternative ideas that are realistic, workable and detailed. Ideas demonstrate detailed understanding of materials, processes and techniques supported by research information. Ideas address all specification points. Client/user-group feedback shown.	7-10
Present alternative design ideas that are realistic and workable. Ideas are detailed and use relevant research. Ideas address most specification points.	4-6
Present alternative design ideas that are similar and simplistic. Ideas are similar and use limited research. Limited specification points are addressed.	1-3

C. Design and development — Review

Level of response	Mark range
Present objective evaluative comments against most specification points that consider client/user-group feedback. Evaluative comments include realistic issues of sustainability relating to design and resources.	3-4
Present general and subjective comments against some specification points. An aspect of sustainability is evaluated superficially.	1-2



C. Design and development — Develop

Level of response	Mark range
<p>Development is used to produce a final design proposal that is significantly different and improved compared to any previous alternative design ideas.</p> <p>A final design proposal is presented that includes technical details of materials and/or components, processes and techniques.</p> <p>Modelling to scale using traditional materials or 2D and/or 3D computer simulations is used to test important aspects of the final design proposal against relevant design criteria.</p> <p>Client/user-group feedback is used for final modifications.</p>	7-10
<p>Developments are appropriate and use details from alternative design ideas to change, refine and improve the final design proposal.</p> <p>A final design proposal is presented that includes some details of materials, and/or components, processes and techniques.</p> <p>Modelling using traditional materials is used to test some aspects of the final design proposal against relevant design criteria.</p>	4-6
<p>Developments from alternative design ideas are minor and cosmetic.</p> <p>A final design proposal is presented that includes superficial details of materials and/or components, processes and techniques.</p> <p>Simple modelling is used to test an aspect of the final design proposal against a design criterion.</p>	1-3

C. Design and development — Communicate

Level of response	Mark range
<p>Use a range of communication techniques and media including ICT and CAD,</p> <ul style="list-style-type: none"> • that are carried out with precision and accuracy • to convey enough detailed and comprehensive information to enable a third-party to manufacture the final design proposal. 	4-6
<p>Use a range of communication techniques, including ICT</p> <ul style="list-style-type: none"> • that are carried out with sufficient skill • to convey an understanding of design and develop intentions and construction details of the final design proposal. 	1-3

D. Planning

Level of response	Mark range
<p>Produce a detailed production plan that considers the main stages of manufacture in the correct sequence appropriate to the scale of production.</p> <p>Realistic and achievable timescales and deadlines are evidenced for the scale of production.</p> <p>Quality and safety checks are shown and justified.</p>	4-6
<p>Produce a production plan that considers the main stages of manufacture.</p> <p>Reference to time and scale of production is shown.</p> <p>Quality and safety are evidenced superficially.</p>	1-3

E. Making — Use of tools and equipment

Level of response	Mark range
Select tools and equipment for specific uses independently. Use with precision and accuracy. High level of safety awareness, for self and others, when using specific tools and equipment.	7-9
Select appropriate tools and equipment with some guidance. Use with some skill and attention to detail. Show sufficient levels of safety awareness, for self and others, when using specific tools and equipment.	4-6
Select general tools and equipment with guidance. Use with limited skill and attention to detail. Show a limited level of safety awareness, for self and others, when using specific tools and equipment.	1-3

E. Making — Quality

Level of response	Mark range
Display a detailed understanding of the working properties of materials used <ul style="list-style-type: none"> • with justification for their selection. Display a justified understanding of the use of manufacturing processes. Produce a high-quality product <ul style="list-style-type: none"> • that matches all aspects of the final design proposal • and functions fully. 	11-16
Display a good understanding of the working properties of materials used <ul style="list-style-type: none"> • with relevant reasons for their selection. Display a good understanding of the use of relevant manufacturing processes. Produce a product that matches the final design proposal <ul style="list-style-type: none"> • and functions adequately. 	6-10
Display a limited understanding of the working properties of materials used <ul style="list-style-type: none"> • with limited reasoning for their selection. Display a limited understanding of the use of manufacturing processes. Produce a product that barely matches the final design proposal <ul style="list-style-type: none"> • and functions poorly. 	1-5

E. Making — Complexity/level of demand

Level of response	Mark range
The complexity of task is challenging. A wide range of skills is required, <ul style="list-style-type: none"> • demonstrating precision and accuracy in their use. 	7-9
The complexity of task offers some challenge. A range of skills is required <ul style="list-style-type: none"> • demonstrating attention to detail in their use. 	4-6
The complexity of task is undemanding. A limited range of skills is needed that <ul style="list-style-type: none"> • require little attention to detail in their use. 	1-3



F. Testing and evaluating

Level of response	Mark range
<p>A range of tests justified and carried out to check the performance and/or quality of the final product. Objective evaluative comments, including third-party evaluation, consider most relevant, measurable specification points in detail.</p> <p>Suggestions for modifications that are justified from tests carried out focus on improving performance and/or quality of the final product.</p> <p>Relevant and useful life cycle assessment carried out on the final product to check its sustainability.</p>	7-10
<p>A range of tests carried out to check the performance and/or quality of the final product. Evaluative comments are objective and reference most specification points.</p> <p>Suggestions for modifications are relevant and are justified from tests that were carried out.</p>	4-6
<p>One or more simple tests carried out to check the performance and/or quality of the final product. Evaluative comments are subjective and reference a few specification points superficially.</p> <p>Suggestions for modifications are cosmetic.</p>	1-3

TOTAL NUMBER OF MARKS AVAILABLE 90

Unit 1: Portfolio of Creative Skills — Building a portfolio

Student portfolios should contain a variety of evidence covering a wide range of skills and demonstrating an in-depth knowledge and understanding of the subject. The portfolio can comprise several separate investigating, designing and making tasks, or a few combined design and make tasks. The resulting three parts of a student’s portfolio should be assessed holistically.

For example: Separate investigating, designing and making tasks

Product investigation	Product design	Product manufacture
Product investigation 1: Analyse and research into an adjustable desk lamp.	Design task 1: Design a mechanical device that can crush aluminium drinks cans to less than one-third their original length.	Making task 1: Manufacture a wooden jewellery box from given working drawing and design requirements.
Product investigation 2: Analyse and research into a laminated dining chair.	Design task 2: Design a portable artist’s easel for use outside.	Making task 2: Accurately replicate an aluminium chess piece from an existing piece, using lathe and milling techniques.
	Design task 3: Design a range of coordinating jewellery based on a modular theme.	Making task 3: Manufacture the range of modular jewellery from Design task 3.

For example: Combined design and make tasks

Product investigation	Product design	Product manufacture
Product investigation 1: Analyse of an adjustable desk lamp.	Design task 1: Design an adjustable desk lamp with two axes of movement.	Making task 1: Manufacture an adjustable desk lamp with at least two axes of movement.
Product investigation 2: Analyse of a laminated dining chair.	Design task 2: Design a small piece of furniture that uses laminated forms in its construction.	Making task 2: Manufacture a small piece of furniture that uses laminated forms in its construction.



Unit 1: Portfolio of Creative Skills — Exemplar student work

Product Design — Design and development criteria (18 marks)

There are a number of possible starting points for this section. The design brief(s)/needs(s) may be given to the students by the teacher or they may define their own.

The following are two possible types of brief students may want to use:

- a focused design brief for a specific need/want
- a 'blue sky' project resulting in concepts using future technology.

A detailed design specification is not required. However, design brief(s)/needs(s) must contain a range of design criteria that students' final design proposals must meet.

In the following example the design brief was given to students by the teacher. This individual brief was part of a series of briefs focusing on a wide range of design skills involving different scenarios and different materials.

Design brief/need

Design a 'bathroom tidy' that can be used to store toothbrushes and a water glass safely.

Your design should:

- *hold at least four toothbrushes securely*
- *accommodate a glass of your choice*
- *be hygienic and easily cleaned*
- *be suitable for production in high volume.*

What students need to evidence

Students should consider the design problem and produce a range of alternative ideas that focus on the whole or parts of the problem.

Students do not need to produce a wide range of alternative ideas. It is better to produce more focused work of a higher quality than a lot of work of lesser quality.

Students should explore different design approaches in their work, applying their knowledge of materials, components, processes and techniques to produce realistic design proposals that satisfy the design brief(s)/need(s).

Students should evaluate each one of their designs objectively against the criteria set out in their design brief(s)/need(s) to ensure that their designs are realistic and viable.

The use of detailed annotation is an important feature of design development and students should use it to explain details of their design thinking and to offer thoughts on their design proposals.

Example of a medium level of response

The following sheets outline a medium level of response to a teacher-set design brief. The moderator clearly makes suggestions for further improvement of the student's work.

Sheet 1:

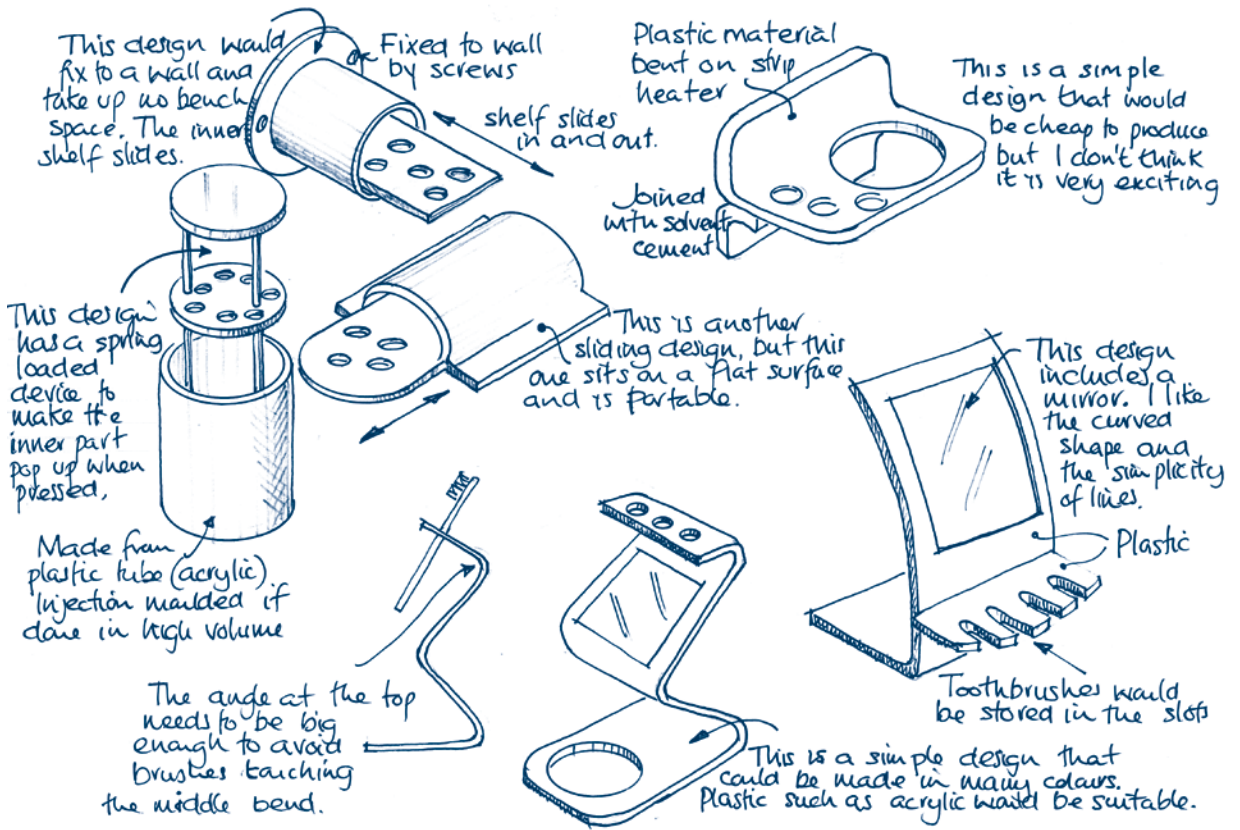

Sheet 2:

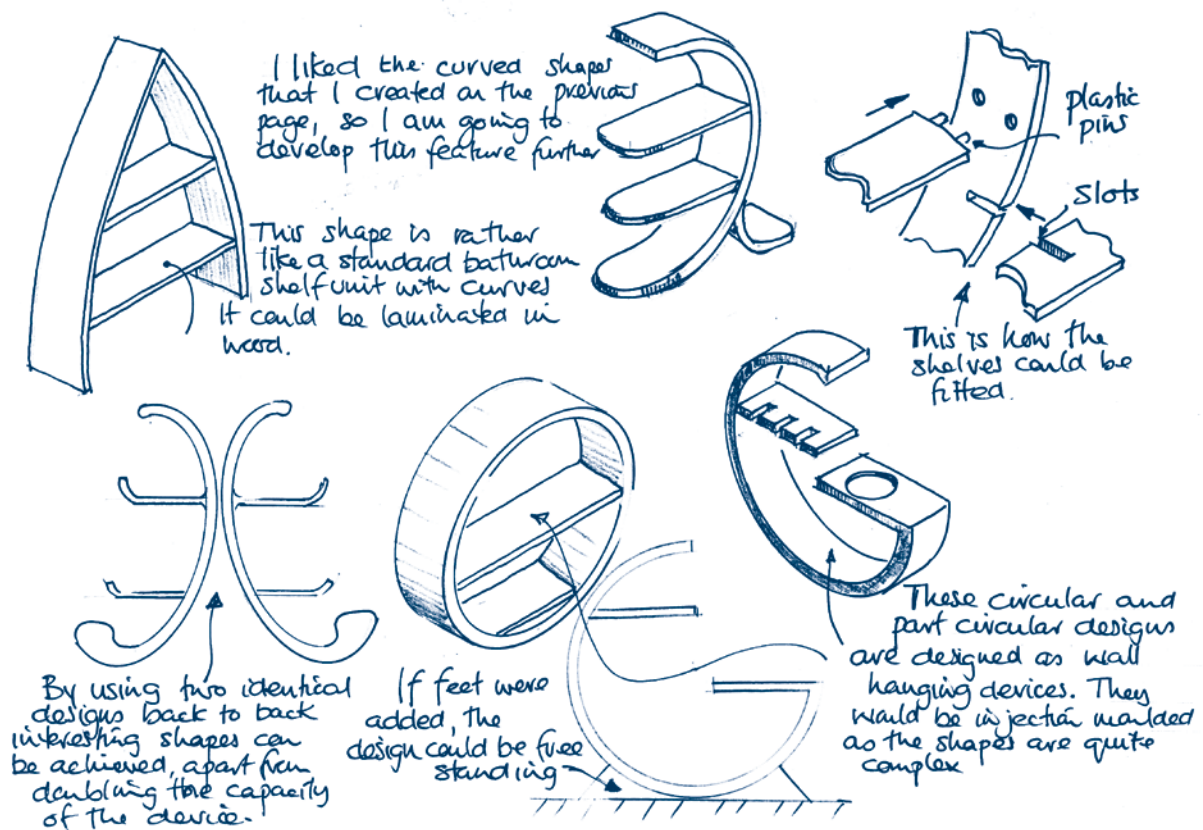
**Moderator comments: Sheets 1 and 2**

The design ideas presented are realistic and show some details of materials and processes used. Some aspects of the design criteria are addressed, but not in great detail.

In order to achieve the high level of response, more detail of the justified selection of materials and processes is required, along with an evaluation of each individual design idea set against the design criteria. Design details of sub-systems, mechanisms etc should also be explored graphically and this would help lift the level of response.

Sheet 3:

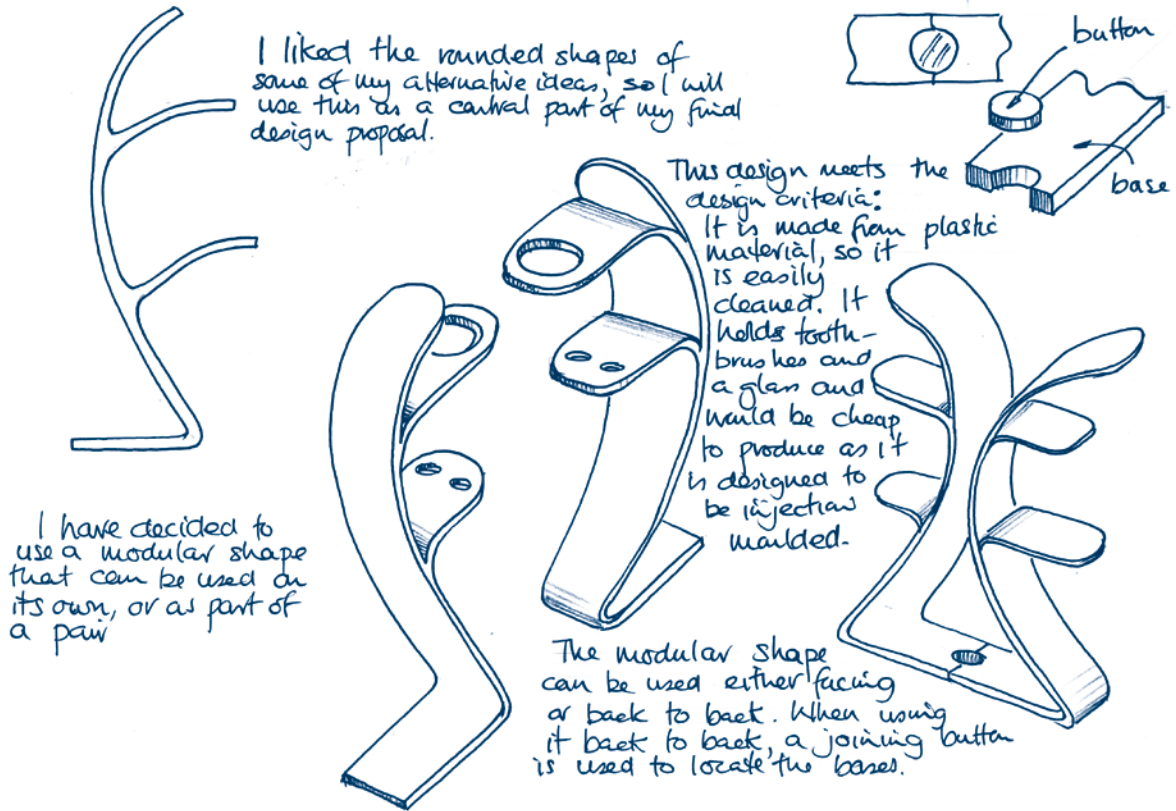

Moderator comments: Sheet 3

The final design proposal references initial alternative ideas and is influenced by them.

In order to achieve the high level of response, more technical detail relating to the selected materials, processes and techniques is required. Greater graphical information of how shapes and sub-systems would be produced would also lift the level of response. For example, there are no details supplied regarding the 'button' or how it would hold the two base pieces in place. Exploration of other holding methods would lift response levels.

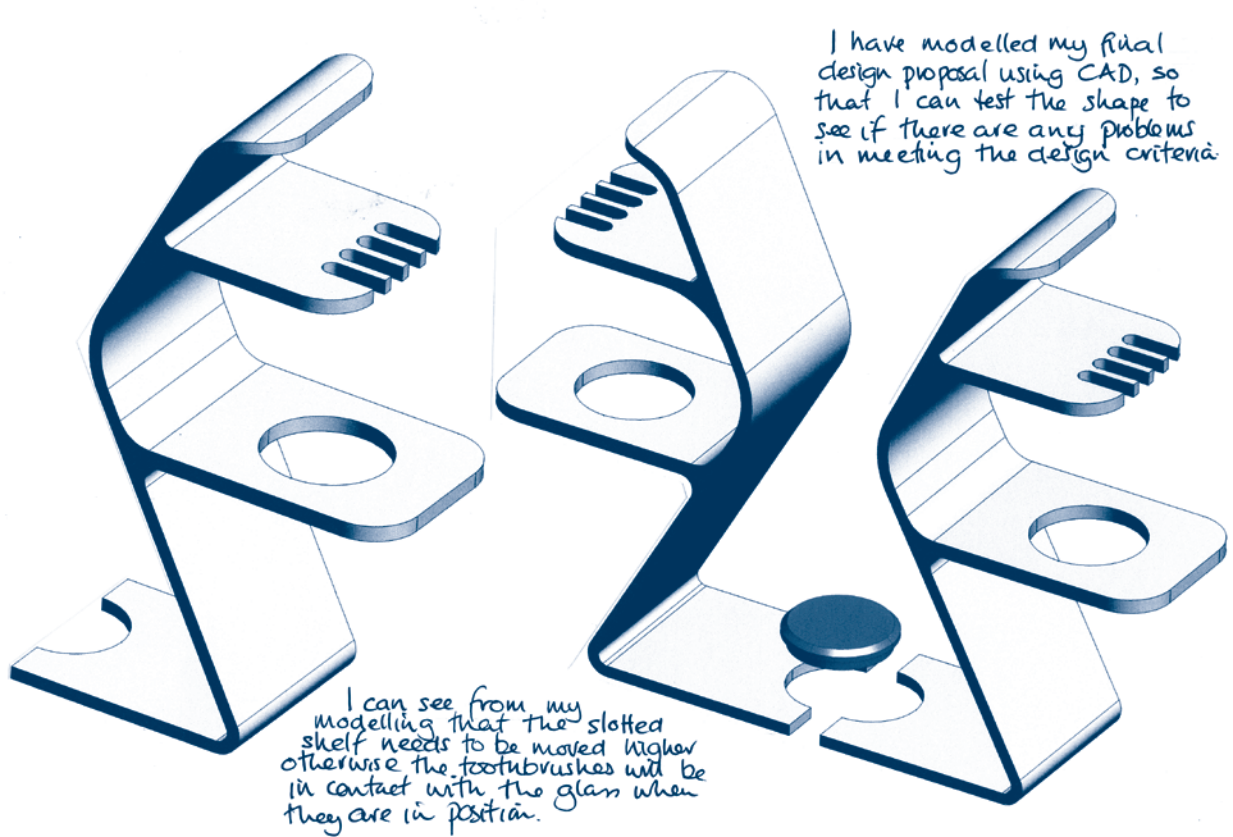
Sheet 4:

Sheet 5:

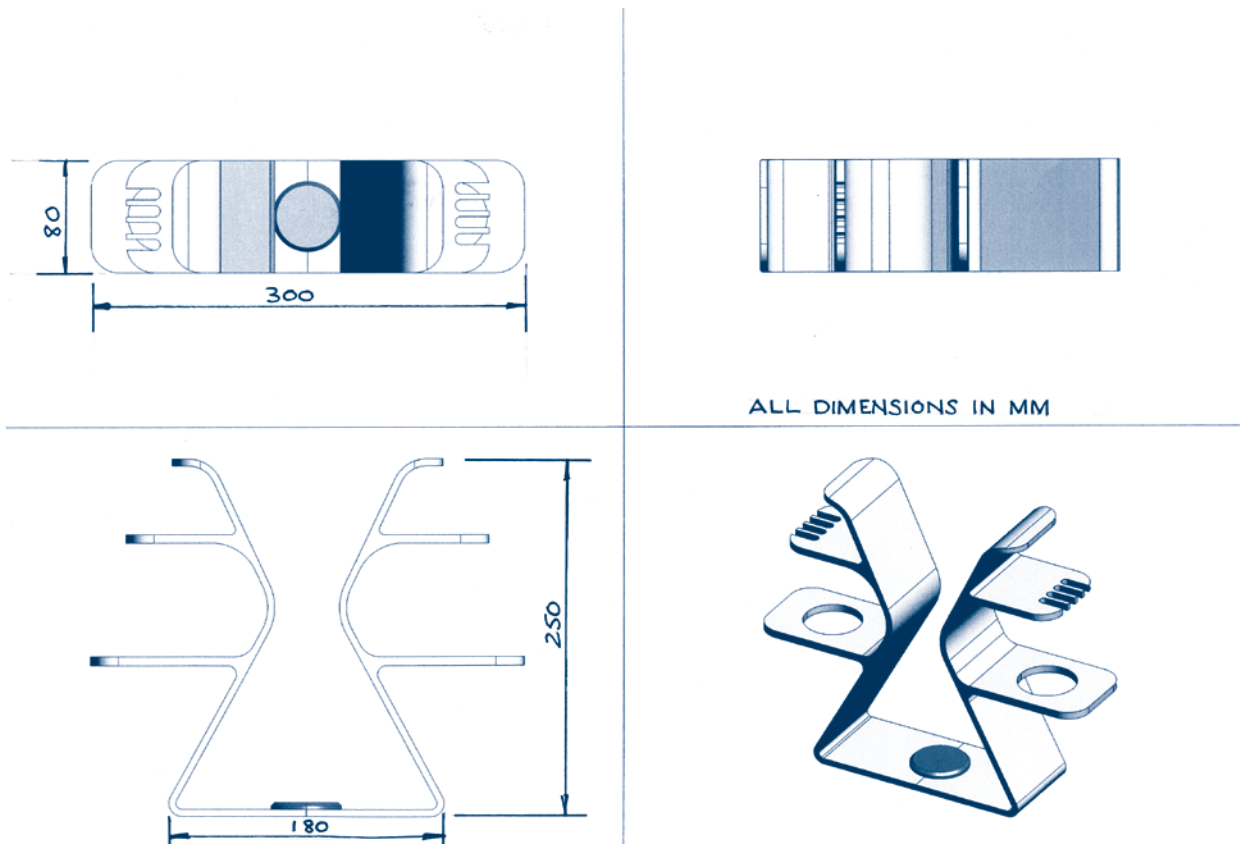

Moderator comments: Sheets 4 and 5

The design is modelled in 3D CAD and some information is gained from this, highlighting a design flaw, but no modifications are suggested to overcome the problem. The formal working drawing is included to indicate dimensions of the 'bathroom tidy', but this is basic and not very helpful.

To achieve the high level of response, more reference should be made to the design criteria, and how the final design proposal meets them. Physical modelling in resistant materials would show what the design proposal looked like in 'the real world' and would generate more useful information.

Any formal drawings should be fully dimensioned and complete. Recording conclusions drawn from modelling, and any resulting design changes or modifications, would increase the level of response, as would a detailed and objective evaluation of the final design proposal. Comments from potential users would provide valuable third party feedback.



Recommended websites

The following websites may be useful for students. The list is not definitive, but gives suggestions as starting points for further research.

Please note that while website addresses are checked at the time of publication, website addresses may change at any time.

The numbers in brackets represent the sections from the unit content that the websites relate to.

Unit 1: Portfolio of Creative Skills and Unit 4: Commercial Design

Design analysis (1.3, 1.4, 4.3)

<http://greatchairdesign.com>

www.bbc.co.uk/schools/gcsebitesize/design/resistantmaterials/designanalysevaluationrev2.shtml

General design interest (1.3, 1.4, 1.5, 4.3)

www.designcouncil.org.uk

www.designmuseum.org/design

www.design-technology.info/cwhelp/page10.htm

www.design-technology.info/home.htm

www.lucidinnovation.com

Unit 2: Design and Technology in Practice

For general/basic information on materials/processes (2.3, 2.4, 2.5)

<http://manufacturing.stanford.edu>

www.design-technology.info/alphaindex/index.htm

www.engineersedge.com/manufacturing.htm

Woods and their properties (2.3, 2.4)

<http://diydata.com/materials/manmadeboard/manmadeboard.php>

www.woodbin.com/ref/wood

General information including conversion/seasoning of wood (2.4)

www.geoffswoodwork.co.uk

Teaching resources for timber

www.timber.org.au/NTEP/menu.asp?section=Teaching

Plastics and processing (2.3, 2.4)

www.bpf.co.uk

www.design-technology.info/graphics/page9.htm

Carbon fibre (2.3)

www.diseno-art.com/tutorials/carbon_fiber.html

Glass Reinforced Plastic (2.3)

www.diseno-art.com/tutorials/fiberglass.html

Smart materials (2.3)

www.cs.ualberta.ca/~database/MEMS/sma_mems/index2.html

www.tep.org.uk/PDF/QTC.pdf

Mechanisms (2.3)

www.cs.cmu.edu/~rapidproto/mechanisms/chpt2.html

Adhesives (2.4)

www.learning.luton.gov.uk/index.cfm?s=1&m=251&p=89,view_resource&start=1&kw=&el=&sc=6&id=967

Total quality management, quality assurance, quality control (2.5)

www.design-technology.info/QAandQC/default.htm

www.schoolforchampions.com/tqm/

www.strategosinc.com/iso_9000.htm

Health and safety (2.6)

www.hse.gov.uk/legislation/hswa.htm

www.hse.gov.uk/pubns/indg163.pdf



Unit 3: Designing for the Future

General — useful search index
www.design-technology.info/alphaindex/index.htm
EDI, ISDN, LAN, global networks, videoconferencing (3.3)
http://en.wikipedia.org/wiki/Electronic_Data_Interchange
Just In Time systems (3.3, 3.4)
http://open-site.org/Business/Terminology/Stock_Control/Just_in_Time
www.strategosinc.com/just_in_time.htm
Flexible manufacturing systems (3.3, 3.4)
http://en.wikipedia.org/wiki/Flexible_manufacturing
www.uky.edu/~dsianita/611/fms.html
Biopol® (3.3)
www.science.org.au/nova/061/061key.htm
Plasticisers (3.3)
www.azom.com/details.asp?ArticleID=1224
Scales of production (3.5)
www.design-technology.info/batch/default.htm
Influences of design history on development of products (3.5)
www.designmuseum.org/design
www.design-technology.info/designers/default.htm
Sustainability (3.6)
http://en.wikipedia.org/wiki/Sustainable_design
www.gdrc.org/uem/lca/life-cycle.html
Waste management/recycling (3.6)
http://en.wikipedia.org/wiki/Waste_Management
www.recyclenow.com
www.recycling-guide.org.uk/facts.html
Energy sources (3.6)
http://en.wikipedia.org/wiki/Renewable_energy
www.eia.doe.gov/kids/energyfacts/sources/whatsenergy.html
Systems and control concurrent manufacture
http://best.me.berkeley.edu/~pps/pps/concurrent.html

Graphic Products

Exemplar scheme of work	39
Integrating Unit 2 content through the delivery of Unit 1	41
External assessed units — Units 2 and 3	42
• Mapping sample assessment materials (SAMs) to unit content	42
• Glossary of terms	46
Internal assessed units — Units 1 and 4	48
• Guidance in applying the assessment criteria	48
• Breakdown of each assessment criterion	49
• Unit 1: Portfolio of Creative Skills — Building a portfolio	57
• Unit 1: Portfolio of Creative Skills — Exemplar student work	58
Recommended websites	64



Exemplar scheme of work

Unit 1: Portfolio of Creative Skills — Product investigation

Outline scheme of work

In this example the teacher leads the exercise and all students are to investigate the same product — a perfume bottle and its box. This will act as the basic template for students when they study a product of their own choice later on in the term. Additionally, this will give each student two complete product investigations, the better of the two will be submitted for assessment in their final portfolio.

This outline scheme of work is based on a five-hours-per-week timetable allocation over a period of five weeks.

WEEK 1

Graphical study task

To study the perfume bottle and box in detail, taking accurate measurements, to produce:

- a an accurate full-scale 3rd angle orthographic drawing of perfume bottle
- b an accurate technical construction of the box development including dimensioning. (Could be undertaken using ProDesktop.)

Independent study time

Task: To fully label all components and add component list to working drawing.

WEEK 2

Performance analysis task

- a To produce a technical specification for the bottle and box, including:
 - i **Form** — why is the bottle and box shaped/styled as they are?
 - ii **Function** — what are the purposes of the bottle and box?
 - iii **User requirements** — what qualities make the perfume and box attractive to potential users?
 - iv **Performance requirements** — what are the technical considerations that must be achieved within the bottle and box?
 - v **Material and component requirements** — how should materials and components perform within the bottle and box?
 - vi **Scale of production and cost** — how does the design allow for scale of production and what are the considerations in determining cost?
- b To analyse another perfume bottle using the same criteria and compare and contrast it with the one studied in class.

Independent study time

Task: To identify the materials used for the components in the bottle and box.

WEEK 3

Materials and components task

Using their fully labelled working drawing and development drawing from Week 1 students:

- a evaluate the use of the materials and components selected for the manufacture of the bottle and box
- b investigate suitable alternative materials in terms of quality and performance. Evaluate alternative materials in comparison to those actually used.

Independent study time

Task: To research the potential environmental impact of material extraction and modern manufacturing processes.

WEEK 4

Materials and components task (continued)

- c explain the environmental effects of using the materials identified in the manufacture of the bottle and box in relation to the following:
- extraction and processing of raw materials
 - production processes
 - disposal of products after their useful lifespan.

Manufacturing task

Using their fully labelled working drawing and development drawing from Week 1:

- a identify and describe the processes involved in the manufacture of the bottle and box
b evaluate the use of the processes selected.

Independent study time

Task: To complete parts a and b of the manufacture task.

WEEK 5

Manufacture task (continued)

- c identify one alternative method of manufacturing the perfume bottle and box and compare and contrast it with the methods actually used
d describe the effects that the processes used to manufacture the bottle and box have on the environment.

Quality task

Using the manufacturing processes identified in the previous task:

- a identify and describe the range of quality control (QC) checks that have taken place during the manufacture of the bottle and box
b describe the quality assurance (QA) system for the manufacture and after-sales service of the product
c identify and describe some of the main standards that must be met during product manufacture and how they influence production and the final product.

Independent study time

Task: To complete all outstanding work in preparation for assessment.



Integrating Unit 2 content through the delivery of Unit 1

The example: Product investigation of a perfume bottle and box.

Assessment criteria	High level of response	Appropriate Unit 2 content
A. Performance analysis	Fully justify key technical specification points that relate to form, function, user requirements, performance requirements, materials and/or component requirements, scale of production and costs. Compare and contrast one other existing similar product using the technical specification.	<p>Materials and components</p> <p>Properties, application, advantages/disadvantages of carton boards for the box.</p> <p>Properties, application, advantages/disadvantages of metals or polymers for the bottle (in addition to glass not in specification).</p> <p>Industrial and commercial practice</p> <p>Characteristics, application and advantages/disadvantages of mass production. Production and advantages/disadvantages of processes for creating structural packaging nets.</p> <p>Characteristics, preparation, processes, application and advantages/disadvantages of thermoforming techniques for the bottle (in addition to glass manufacturing processes not in specification).</p> <p>Processes, application and advantages/disadvantages of finishes for enhancing the format of the board for the box.</p> <p>Processes, application and advantages/disadvantages of printing processes for the box.</p>
B. Materials and components	Suggest, with reference to quality and performance, alternative materials and/or components that could have been used in the product. Evaluate, using advantages and disadvantages, the selection of the materials and/or components used. Describe the impact on the environment of using the materials and/or components identified.	<p>Materials and components</p> <p>Properties, application, advantages/disadvantages of carton boards for the box.</p> <p>Properties, application, advantages/disadvantages of metals or polymers for the bottle (in addition to glass not in specification).</p>
C. Manufacture	Evaluate, using advantages and disadvantages, the selection of the manufacturing processes used in the product. Suggest one alternative method of production that could have been used in the manufacture of the product. Describe the impact on the environment of using the processes identified in the production of the product.	<p>Industrial and commercial practice</p> <p>Production and advantages/disadvantages of processes for creating structural packaging nets.</p> <p>Characteristics, preparation, processes, application and advantages/disadvantages of thermoforming techniques for the bottle (in addition to glass manufacturing processes not in specification).</p> <p>Processes, application and advantages/disadvantages of finishes for enhancing the format of the board for the box.</p> <p>Processes, application and advantages/disadvantages of printing processes for the box.</p>
D. Quality	Describe a range of quality control checks used during the manufacture of the product and explain how the main relevant standards influenced the manufacture of the product. Describe a quality assurance (QA) system for the product.	<p>Quality</p> <p>Concept, characteristics, application and advantages of QA, QC and TQM when manufacturing the perfume bottle and box.</p> <p>Quality control during the final print run of the box using printer's marks.</p> <p>Meeting specifications and tolerances.</p> <p>Process of testing products, components and materials against external quality standards set by relevant organisations.</p>

External assessed units — Units 2 and 3

Mapping sample assessment materials (SAMs) to unit content

The following section shows how each question in the SAMs for these units were mapped against the specification unit content.

Unit 2: Design and Technology in Practice

Question 1	Clarification	Content
(a)(i) and (ii)	A straightforward question about ferrous and non-ferrous metals and their application in packaging. Designed to ease candidates into the paper.	Materials and components — Materials b) Metals
(b)(i)	This question directly addresses the use of printer's marks for quality control during a print run.	Quality — Quality assurance systems and quality control in production
(b)(ii)	This question requires candidates to apply their knowledge and understanding of the stated polymers to given applications. Why is this polymer most suited to the product? A product is used to focus candidate responses.	Materials and components — Materials c) Polymers
Question 2	Clarification	Content
(a)	A straightforward question that requires candidates to know which adhesives to use when joining different materials.	Industrial and commercial practice — Joining techniques
(b)	Candidates need to recognise the aesthetic and functional properties of MDF and apply them to making block models.	Materials and components — Materials e) Composites
(c) and (d)	Candidates need to be familiar with two methods of producing block models when developing a product. Block modelling is a widely practised method for candidates to use to model their ideas but they must also study how professional designers can quickly achieve accurate models using CAD/CAM.	Industrial and commercial practice — Modelling and prototyping
Question 3	Clarification	Content
(a)	A graphical communication question. Therefore, candidates will need to have practised the drawing techniques listed. Candidates are asked to translate an isometric drawing to a working drawing.	Industrial and commercial practice — Graphical communication
(b)(i)	This question requires that candidates know the characteristics of mass production and apply its advantages to the manufacture of the given product.	Industrial and commercial practice — Scale of production
(b)(ii)	This question requires candidates to apply their knowledge and understanding of the stated polymers to given applications. Why are these polymers most suited to the product? A product is used to focus candidate responses.	Materials and components — Materials c) Polymers
Question 4	Clarification	Content
(a)(i) and (ii)	The first part is a straightforward one mark question where two different responses would be acceptable. The second part requires candidates to be familiar with HSE risk assessments when using computers. This is an important aspect of the modern design of graphic products using ICT.	Health and safety — Health and Safety at Work Act (1974)



(b)	A straightforward question requiring candidates to have a good working knowledge and understanding of DTP when designing printed products.	Industrial and commercial practice — Computer generated graphics
(c)(i) and (ii)	Candidates must be familiar with the advantages and disadvantages of the types of binding methods listed and apply this knowledge and understanding to a glossy magazine.	Materials and components — Components
Question 5	Clarification	Content
(a), (b) and (c)	These questions appear at the end of the paper and are intended to stretch and challenge. Candidates should have studied thermochromic film in depth to ascertain its structural composition and explain how it works in a given situation. Knowledge and understanding is applied to forehead thermometers.	Materials and components — Materials g) Smart materials
(d)	This question requires candidates to have studied the key concepts behind quality assurance systems — the different aspects of quality control when purchasing materials, throughout the production process and after-sales care.	Quality — Quality assurance systems and quality control in production

NB: Please note that questions cover the four sections of this unit. No paper will ever focus entirely on one section. It is also anticipated that consecutive years will address different parts of the unit content to give full unit coverage. Therefore, it is important that students are familiar with the content for the whole unit and are given plenty of opportunities to answer examination style questions throughout the course to prepare them for the final examination.

Unit 3: Designing for the Future

Question 1	Clarification	Content
(a)(i) and (ii)	A straightforward question to start the paper where candidates are asked to give the advantages of shopping online. The second part focuses on the advantages to the retailer of using EPOS systems so candidates must be familiar with the EPOS process.	Industrial and commercial practice — Information and communication technology (ICT)
(b)(i-iv)	This question elicits a response which both examines a candidate's knowledge and understanding of the 4 R's and applies it to an everyday product.	Sustainability — Minimising waste production
Question 2	Clarification	Content
(a)	Candidates are asked to apply their knowledge and understanding of the principles of ergonomics to a familiar product.	Design in context — Anthropometrics and ergonomics
(b)(i)	This question requires that candidates know and understand the use of ICT in the global design of products, where products are no longer designed and made in the same country.	Industrial and commercial practice — Information and communication technology (ICT)
(b)(ii)	This question deals with the global marketplace and, in particular, the impact of offshore manufacturing in developing countries on the local community.	Design in context — The effects of technological changes on society
Question 3	Clarification	Content
(a)(i) and (ii)	A straightforward question which requires candidate's to be familiar with the advantages and disadvantages of renewable and non-renewable sources of energy.	Sustainability — Renewable and non-renewable sources of energy
(b)(i) and (ii)	Candidates need to have studied both elements of this section in order to give a detailed and comprehensive response. Knowledge and understanding of both; the use of genetic engineering in the paper and board industry and the production of Biopol®.	Industrial and commercial practice — Biotechnology
Question 4	Clarification	Content
(a)(i) and (ii)	This is a new style of question which asks candidates to compare the form and function of two similar products. Phillipe Starck's 'Hot Bertaa' kettle is used as an iconic piece of product design in asking a question regarding form versus function.	Design in context — Influences of design history on the development of products AND Design in context — Form and function
(b)(i) and (ii)	Candidates are asked to discuss, in depth, two key advantages of using CIM systems; efficient manufacture and a safer working environment.	Systems and control — Computer integrated manufacture (CIM)
Question 5	Clarification	Content
(a)	This question is concerned with the impact of the miniaturisation of products.	Design in context — The effects of technological changes on society
(b)	The final question in the paper is designed to stretch and challenge candidates. Candidates should have studied all the key topics in this section in order to give a detailed response.	Systems and control — Robotics and Artificial Intelligence (AI)



NB: Please note that questions cover the four sections of this unit. No paper will ever focus entirely on one section. It is also anticipated that consecutive years will address different parts of the unit content to give full unit coverage. Therefore, it is important that students are familiar with the content for the whole unit and are given plenty of opportunities to answer examination style questions throughout the course to prepare them for the final examination.

Glossary of terms

Unit 2: Design and Technology in Practice

Each section in the unit content carries a 'stem' explaining what students specifically need to learn for this examination.

For example:

c) Polymers

Aesthetic, functional and mechanical properties, application and advantages/disadvantages of the following thermoplastics in the production of graphic products and commercial packaging:

(followed by the list of specific polymers)

Students need to be familiar with the specific properties of the polymers listed, where they are best used and why. The stem is further clarified by the use of polymers in graphic products (eg point-of-sale, product casings) and commercial packaging only. A question will not be asked, for example, on why PVC is best used for drainpipes.

The following are the main terms used in this unit.

Key term in section stem	Meaning
Aesthetic properties	The visual qualities of materials.
Functional properties	The qualities a material must possess in order to be fit for purpose, eg the correct weight, grade, size.
Mechanical properties	The material's reaction to physical forces, eg strength, plasticity, ductility, hardness, brittleness, malleability.
Application	The quality of being usable for a particular purpose or in a special way; relevance.
Advantages/disadvantages	Qualities and features favourable to success or failure.
Processes	A description of the systematic series of actions needed to produce something.
Structural composition	How a material is made up.
Characteristics	Recognisable features that help to identify or differentiate one process from another.
Demonstration	Practical evidence of graphical drawing techniques.
Preparation	Action required before a process can begin.
Production/manufacture	The process of manufacture.
Concept	The general idea behind the use of quality assurance systems.
Principles	The distinct reasons for health and safety legislation.



Unit 3: Designing for the Future

Each section in the unit content carries a 'stem' explaining what candidates specifically need to learn for this examination.

For example:

Computer integrated manufacture (CIM)

Characteristics, processes, application, advantages/ disadvantages and its impact on employment of CIM systems to integrate the processing of production and business information with manufacturing operations, including:

(followed by a list of characteristics of CIM systems)

Students have to study a wide range of aspects relating to the use of CIM systems. Firstly, students need to develop an in-depth knowledge and understanding of the features of CIM systems and how they are used to produce products. Then, they must explain the advantages and disadvantages of using CIM systems, in particular their effect on the modern workforce.

The following are the main terms used in this unit.

Key term in section stem	Meaning
Application	The quality of being usable for a particular purpose or in a special way; relevance.
Advantages/ disadvantages	Qualities and features favourable to success or failure.
Processes	A description of the systematic series of actions in order to produce something.
Characteristics	Recognisable features that help to identify or differentiate one process from another.
Production	The process of manufacture.
Principles	The distinct reasons for something.
Impact	Effects felt as a result of man's intervention/ modern systems.
Sources	Raw materials for processing.
Debate	Discussion involving opposing viewpoints.
Responsibilities	The duty and obligations of developed countries.

Internal assessed units — Units 1 and 4

Guidance in applying the assessment criteria

The following points may help when establishing a final mark for the student's work:

- read through the student's work to form an overall impression of the level of response achieved
- study the evidence presented by the student for each assessment criterion
- read the level of response descriptors for each assessment criterion and identify the group of statements that offer the 'best fit' for a student's work
- match the evidence presented and the individual statements available to further refine the range of marks, eg 7-12, to establish a final score within that range.

Where 'best fit' bridges two levels of response, eg medium and high, and where perhaps two level statements from the high level are met and the rest firmly within the medium level, it would be acceptable to place the overall level of response within the bottom one or two marks of the high level of response category. More statements met from the high level category would earn further credit in that section.

Similarly, if the majority of statements in the medium level of response category were met, but one or two were in the low level of response category, the likely overall mark would be at the low end of the medium level category. More statements judged to be in the low level of response category would lower the overall mark accordingly.

This type of refinement is more likely to be necessary where a substantial range of marks is available at each level of response. The maximum mark range in any group of level descriptors is six.

In Unit 1 — Product manufacture, where students have produced more than one piece of work and each piece focuses on particular skills using specific materials, assessment should be carried out as a holistic exercise, taking into account the range of work produced and the levels of response achieved overall.

Assessment of 'best fit' should be established, but the highest levels of achievement in each assessment category are likely to be derived from different making exercises. Where this is the case, the evidence used to award marks must be clearly photographed and submitted for external moderation.

Breakdown of each assessment criterion

Each assessment criterion has a range of marks. The following tables show how those marks are broken down.

When marking students work, this will help you to determine the final mark to award them for each criterion.

This should be used in conjunction with the information on *Guidance in applying the assessment criteria*.

Unit 1: Portfolio of Creative Skills

Product investigation

Assessment criteria: A. Performance analysis

Level of response	Mark range
Fully justify key technical specification points <ul style="list-style-type: none"> • that relate to form, function, user requirements, performance requirements, materials and/or component requirements, scale of production and costs. Compare and contrast one other existing similar product using the technical specification.	4-6
Identify <ul style="list-style-type: none"> • with some justification • a range of realistic and relevant specification points that include reference to form, function and user requirements. 	1-3

Assessment criteria: B. Materials and components

Level of response	Mark range
Suggest, with reference to quality and performance, alternative materials and/or components that could have been used in the product. Evaluate, using advantages and disadvantages, the selection of the materials and/or components used. Describe the impact on the environment of using the materials and/or components identified.	7-9
Describe a range of useful properties that relate to the materials and/or components identified and <ul style="list-style-type: none"> • justify their selection and use in the product. Identify alternative materials and/or components that could have been used in the product.	4-6
Identify a material or component used in the product. Describe a useful property of that material or component <ul style="list-style-type: none"> • and justify its use. 	1-3

Assessment criteria: C. Manufacture

Level of response	Mark range
Evaluate, using advantages and disadvantages, the selection of the manufacturing processes used in the product. Suggest one alternative method of production that could have been used in the manufacture of the product. Describe the impact on the environment of using the processes identified in the production of the product.	7-9
Describe <ul style="list-style-type: none"> • a range of processes used in the manufacture of the product • and fully justify their use for the level of production of the product. 	4-6
Identify, <ul style="list-style-type: none"> • describe • and justify the use of a manufacturing process used in the construction of the product. 	1-3

Assessment criteria: D. Quality

Level of response	Mark range
Describe a range of quality control checks used during the manufacture of the product <ul style="list-style-type: none"> • and explain how the main relevant standards influenced the manufacture of the product. Describe a quality assurance (QA) system for the product.	4-6
Identify, <ul style="list-style-type: none"> • describe • and justify the use of one quality control check during the manufacture of the product. 	1-3



Product design

Assessment criteria: E. Design and development

Level of response	Mark range
<p>Present alternative ideas that are workable, realistic and detailed and which fully address the design criteria. Ideas demonstrate detailed understanding of materials, processes and techniques.</p> <p>Produce a final design proposal that is significantly different and improved compared to any previous alternative design ideas.</p> <p>The design proposal includes technical details of materials and components, processes and techniques. Modelling through the use of traditional materials or 2D and/or 3D computer simulations is used to test important aspects of the final design proposal.</p> <p>The final design proposal is evaluated objectively against the design criteria in order to fully justify the design decisions taken.</p>	13-18
<p>Present realistic alternative design ideas. Ideas are detailed and address most design criteria.</p> <p>Developments are appropriate and use details from ideas to change, refine and improve the final design proposal.</p> <p>A final detailed design proposal is presented.</p> <p>Modelling is used to test some aspects of the final proposal against relevant design criteria.</p> <p>Evaluative comments objectively consider some aspects of the design brief/need.</p>	7-12
<p>Present simplistic alternative design ideas. Ideas are superficial and address limited design criteria.</p> <p>Developments are minor and cosmetic.</p> <p>A basic final design proposal is presented.</p> <p>Basic modelling is used to test an aspect of the design proposal.</p> <p>Evaluative comments are subjective and superficial.</p>	1-6

Assessment criteria: F. Communicate

Level of response	Mark range
<p>Use a range of communication techniques and media including ICT and CAD,</p> <ul style="list-style-type: none"> • with precision and accuracy • to convey enough detailed and comprehensive information to enable third-party manufacture of the final design proposal. <p>Annotation provides explanation and most technical details of materials and processes with justification.</p>	9-12
<p>Use a range of communication techniques, including ICT</p> <ul style="list-style-type: none"> • that are carried out with sufficient skill • to convey an understanding of design and develop intentions and construction details of the final design proposal. <p>Annotation provides explanation and most technical details of materials and process selection.</p>	5-8
<p>Use a limited range of communication techniques</p> <ul style="list-style-type: none"> • carried out with enough skill • to convey some understanding of design and develop intentions. <p>Annotation provides limited technical details of materials and processes.</p>	1-4

Product manufacture

Assessment criteria: G. Production plan

Level of response	Mark range
Produce a detailed production plan <ul style="list-style-type: none"> • that considers stages of production in the correct sequence, • realistic time scales and deadlines for the scale of production. 	4-6
Produce a limited production plan <ul style="list-style-type: none"> • that considers the main stages of manufacture, • reference to time and scale of production. 	1-3

Assessment criteria: H. Making

Level of response	Mark range
Demonstrate a detailed understanding and justified selection of a range of <ul style="list-style-type: none"> • appropriate materials • and processes. Demonstrate demanding and high quality making skills and techniques. Show accuracy and precision when working with a variety of materials, processes and techniques. High-level safety awareness is evident throughout all aspects of manufacture.	13-18
Demonstrate a good understanding and selection of an appropriate range <ul style="list-style-type: none"> • of materials • and processes. Demonstrate competent making skills and techniques appropriate to a variety of materials and processes. Show attention to detail and some precision. Demonstrate an awareness of safe working practices for most specific skills and processes.	7-12
Demonstrate a limited understanding and selection of a narrow range <ul style="list-style-type: none"> • of materials • and processes. Use limited making skills and techniques. Demonstrate little attention to detail. Demonstrate an awareness of specific safe working practices during product manufacture.	1-6

Assessment criteria: I. Testing

Level of response	Mark range
Describe and justify a range of tests carried out to check the performance or quality of the product(s). Relevant, measurable points of the design brief(s)/need(s) are objectively referenced. Third-party testing is used.	4-6
Carry out one or more simple tests to check the performance or quality of the final product(s). Some points of the design brief(s)/need(s) are referenced superficially. Test results are recorded and are subjective.	1-3

TOTAL NUMBER OF MARKS AVAILABLE	90
--	-----------



Unit 4: Commercial Design — Assessment criteria

A. Research and analysis

Analysis is detailed with most design needs clarified. Research is selective and focuses on the needs identified in the analysis.	3-4
Analysis is limited with some design needs clarified. Research is superficial and does not focus on the needs identified in the analysis.	1-2

B. Product specification

Specification points are realistic, technical and measurable. Specification fully justifies points developed from research in consultation with a client/user-group. Sustainability of resources is realistically considered and relevant when developing specification points.	4-6
Specification points are realistic but not measurable. Some specification points are developed from research in limited consultation with a client/user-group, but are not justified. Sustainability of resources is considered superficially when developing specification points.	1-3

C. Design and development — Design

Present alternative ideas that are realistic, workable and detailed. Ideas demonstrate detailed understanding of materials, processes and techniques supported by research information. Ideas address all specification points. Client/user-group feedback shown.	7-10
Present alternative design ideas that are realistic and workable. Ideas are detailed and use relevant research. Ideas address most specification points.	4-6
Present alternative design ideas that are similar and simplistic. Ideas are similar and use limited research. Limited specification points are addressed.	1-3

C. Design and development — Review

Present objective evaluative comments against most specification points that consider client/user-group feedback. Evaluative comments include realistic issues of sustainability relating to design and resources.	3-4
Present general and subjective comments against some specification points. An aspect of sustainability is evaluated superficially.	1-2

C. Design and development — Develop

Level of response	Mark range
<p>Development is used to produce a final design proposal that is significantly different and improved compared to any previous alternative design ideas.</p> <p>A final design proposal is presented that includes technical details of materials and/or components, processes and techniques.</p> <p>Modelling to scale using traditional materials or 2D and/or 3D computer simulations is used to test important aspects of the final design proposal against relevant design criteria.</p> <p>Client/user-group feedback is used for final modifications.</p>	7-10
<p>Developments are appropriate and use details from alternative design ideas to change, refine and improve the final design proposal.</p> <p>A final design proposal is presented that includes some details of materials, and/or components, processes and techniques.</p> <p>Modelling using traditional materials is used to test some aspects of the final design proposal against relevant design criteria.</p>	4-6
<p>Developments from alternative design ideas are minor and cosmetic.</p> <p>A final design proposal is presented that includes superficial details of materials and/or components, processes and techniques.</p> <p>Simple modelling is used to test an aspect of the final design proposal against a design criterion.</p>	1-3

C. Design and development — Communicate

Level of response	Mark range
<p>Use a range of communication techniques and media including ICT and CAD,</p> <ul style="list-style-type: none"> • that are carried out with precision and accuracy • to convey enough detailed and comprehensive information to enable a third-party to manufacture the final design proposal. 	4-6
<p>Use a range of communication techniques, including ICT</p> <ul style="list-style-type: none"> • that are carried out with sufficient skill • to convey an understanding of design and develop intentions and construction details of the final design proposal. 	1-3

D. Planning

Level of response	Mark range
<p>Produce a detailed production plan that considers the main stages of manufacture in the correct sequence appropriate to the scale of production.</p> <p>Realistic and achievable timescales and deadlines are evidenced for the scale of production.</p> <p>Quality and safety checks are shown and justified.</p>	4-6
<p>Produce a production plan that considers the main stages of manufacture.</p> <p>Reference to time and scale of production is shown.</p> <p>Quality and safety are evidenced superficially.</p>	1-3



E. Making — Use of tools and equipment

Level of response	Mark range
Select tools and equipment for specific uses independently. Use with precision and accuracy. High level of safety awareness, for self and others, when using specific tools and equipment.	7-9
Select appropriate tools and equipment with some guidance. Use with some skill and attention to detail. Show sufficient levels of safety awareness, for self and others, when using specific tools and equipment.	4-6
Select general tools and equipment with guidance. Use with limited skill and attention to detail. Show a limited level of safety awareness, for self and others, when using specific tools and equipment.	1-3

E. Making — Quality

Level of response	Mark range
Display a detailed understanding of the working properties of materials used <ul style="list-style-type: none"> • with justification for their selection. Display a justified understanding of the use of manufacturing processes. Produce a high-quality product <ul style="list-style-type: none"> • that matches all aspects of the final design proposal • and functions fully. 	11-16
Display a good understanding of the working properties of materials used <ul style="list-style-type: none"> • with relevant reasons for their selection. Display a good understanding of the use of relevant manufacturing processes. Produce a product that matches the final design proposal <ul style="list-style-type: none"> • and functions adequately. 	6-10
Display a limited understanding of the working properties of materials used <ul style="list-style-type: none"> • with limited reasoning for their selection. Display a limited understanding of the use of manufacturing processes. Produce a product that barely matches the final design proposal <ul style="list-style-type: none"> • and functions poorly. 	1-5

E. Making — Complexity/level of demand

Level of response	Mark range
The complexity of task is challenging. A wide range of skills is required, <ul style="list-style-type: none"> • demonstrating precision and accuracy in their use. 	7-9
The complexity of task offers some challenge. A range of skills is required <ul style="list-style-type: none"> • demonstrating attention to detail in their use. 	4-6
The complexity of task is undemanding. A limited range of skills is needed that <ul style="list-style-type: none"> • require little attention to detail in their use. 	1-3

F. Testing and evaluating

Level of response	Mark range
<p>A range of tests justified and carried out to check the performance and/or quality of the final product. Objective evaluative comments, including third-party evaluation, consider most relevant, measurable specification points in detail.</p> <p>Suggestions for modifications that are justified from tests carried out focus on improving performance and/or quality of the final product.</p> <p>Relevant and useful life cycle assessment carried out on the final product to check its sustainability.</p>	7-10
<p>A range of tests carried out to check the performance and/or quality of the final product. Evaluative comments are objective and reference most specification points.</p> <p>Suggestions for modifications are relevant and are justified from tests that were carried out.</p>	4-6
<p>One or more simple tests carried out to check the performance and/or quality of the final product. Evaluative comments are subjective and reference a few specification points superficially.</p> <p>Suggestions for modifications are cosmetic.</p>	1-3

TOTAL NUMBER OF MARKS AVAILABLE	90
--	-----------



Unit 1: Portfolio of Creative Skills — Building a portfolio

Student portfolios should contain a variety of evidence covering a wide range of skills and demonstrating an in-depth knowledge and understanding of the subject. The portfolio can comprise several separate investigating, designing and making tasks, or a few combined design and make tasks. The resulting three parts of a student's portfolio should be assessed holistically.

For example: Separate investigating, designing and making tasks

Product investigation	Product design	Product manufacture
Product investigation 1: Analyse different perfume bottles and packaging.	Design task 1: (2D design) Design a magazine cover using ICT.	Making task 1: Produce a Styrofoam™ model of a games controller from a working drawing.
Product investigation 2: Disassemble an MP3 player.	Design task 2: (3D design) Design a hand-held games console.	Making task 2: Produce a MDF block model of a hand-held games console (from Design task 2).
	Design task 3: (2D and 3D) Design a new ice-lolly and packaging for it.	Making task 3: Produce a foam-board architectural model of a building and its interior on the school site.

For example: Combined design and make tasks

Product investigation	Product design	Product manufacture
Product investigation 1: Research and analyse perfume bottles and packaging.	Design task 1: (2D and 3D design) Design a new perfume bottle and packaging.	Making task 1: Produce a model of a new perfume bottle and packaging.
Product investigation 2: Research and analyse MP3/CD players.	Design task 2: (3D design) Design a next generation portable music system.	Making task 2: Produce a model of the next generation portable sound system.

Unit 1: Portfolio of Creative Skills — Exemplar student work

Product Design — Design and development criteria (18 marks)

There are a number of possible starting points for this section. The design brief(s)/needs(s) may be given to students by the teacher or they may define their own.

The following are two possible types of brief which students may want to use:

- a focused design brief for a specific need/want
- a 'blue sky' project resulting in concepts using future technology.

A detailed design specification is not required. However, design brief(s)/needs(s) must contain a range of design criteria that students' final design proposals must meet.

In the following example the design brief was given to candidates by the teacher. This individual brief was part of a series of briefs focusing on a wide range of design skills involving different scenarios and different materials.

Design brief/need

Design a 'travel iron' that can be used on a campsite without mains electricity.

Your design should:

- *be easy to use in an outdoor environment*
- *take up a minimal amount of space in a rucksack and be light enough to be carried around easily*
- *have its own power supply*
- *use materials that are durable and will withstand all likely weather conditions*
- *be designed for mass production.*

This is a fairly straightforward product design brief where students will be exploring a simple and compact product. Obviously, as this is graphic products, the electronic systems involved will not be the driving factor. Students should primarily explore the product's functional and performance criteria with a view to aesthetics as a means of appealing to the target market group.

What students need to evidence

Students should consider the design problem and produce a range of alternative ideas that focus on the whole or parts of the problem.

Students do not need to produce a wide range of alternative ideas. It is better to produce more focused work of a higher quality than a lot of work of lesser quality.

Students should explore different design approaches in their work, applying their knowledge of materials, components, processes and techniques to produce realistic design proposals that satisfy the design brief(s)/need(s).

Students should evaluate each one of their designs objectively against the criteria set out in their design brief(s)/need(s) to ensure that their designs are realistic and viable.

The use of detailed annotation is an important feature of design development and students should use it to explain details of their design thinking and to offer thoughts on their design proposals.

Example of a medium level of response

The following sheets outline a medium level of response to a teacher-set design brief. The moderator clearly makes suggestions for further improvement of the student's work.

Sheet 1:

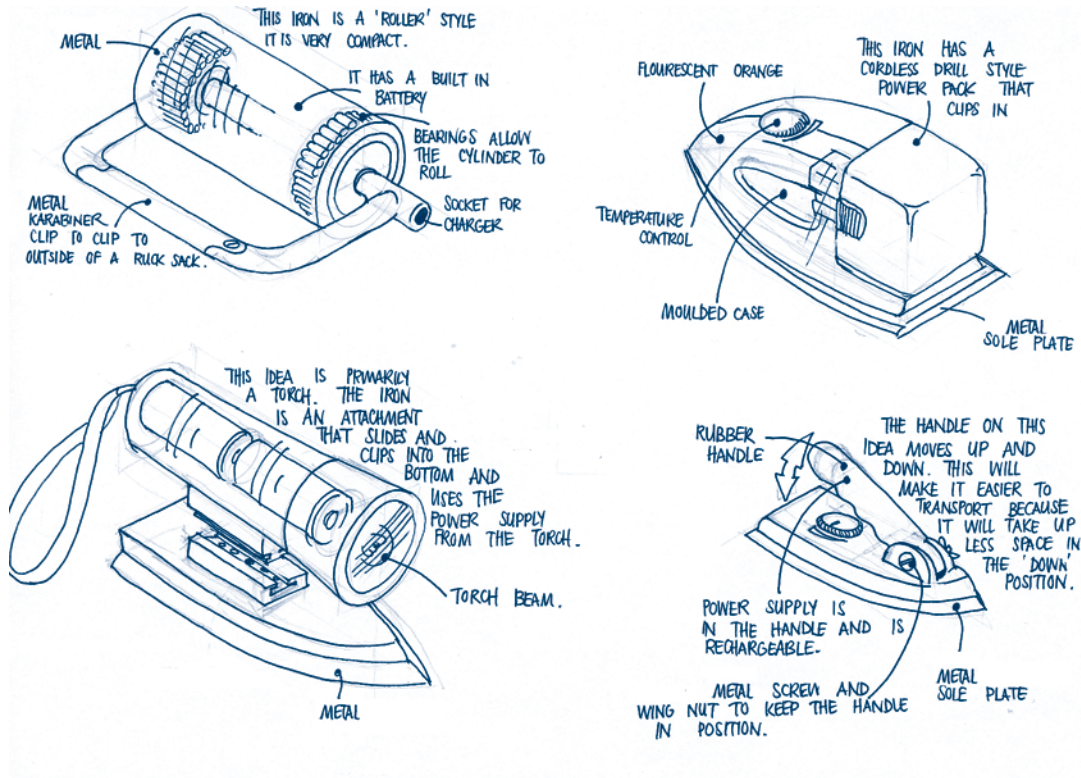

Sheet 2:

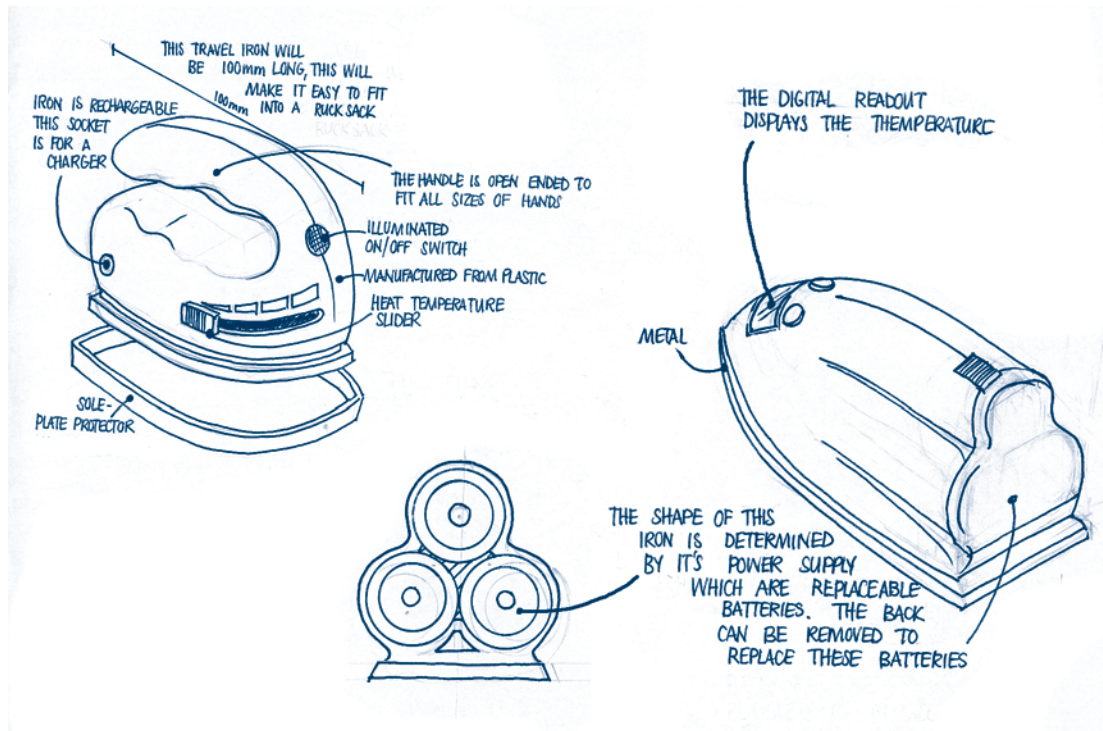

Moderator comments: Sheets 1 and 2

The design ideas presented are realistic and show some details of materials and processes used. Although the communication skills evidenced are of a high quality, only some aspects of the design criteria are addressed and not in great detail.

In order to achieve the high level of response a more detailed understanding of the selected materials, processes and techniques needs to be evidenced. For example, general terms such as 'metal' and 'plastic' should be replaced by specific materials. Reference to particular processes that could be used in product manufacture should also be included in the accompanying annotation. Each design should be evaluated against, and fully meet, the design criteria.

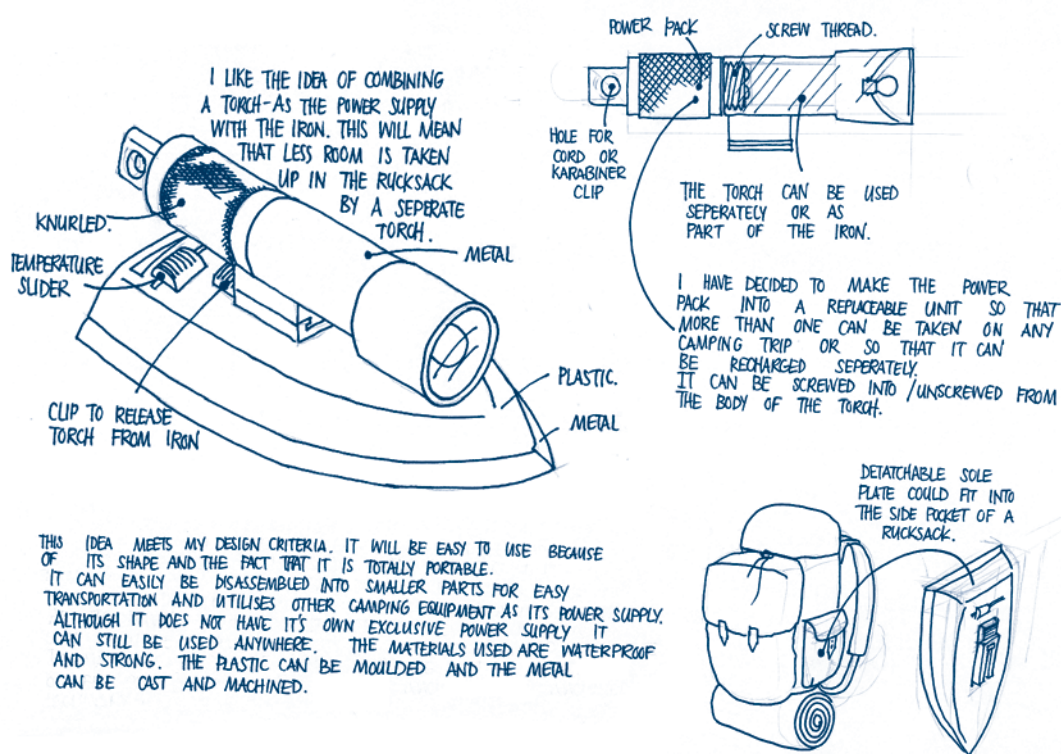

Sheet 3:

**Moderator comments: Sheet 3**

The initial ideas and developments have been used to refine and improve it to produce final design proposal.

In order to achieve the higher level of response the final design needs to include technical details of the materials, processes and techniques used and justification of their selection. Additional information showing how the product would be manufactured and assembled would lift the level of response. For example, there could have featured an exploded diagram showing how the different parts of the product are assembled. Exploration of different ways of locking the two parts of the product together would lift the response levels.

Sheet 4:

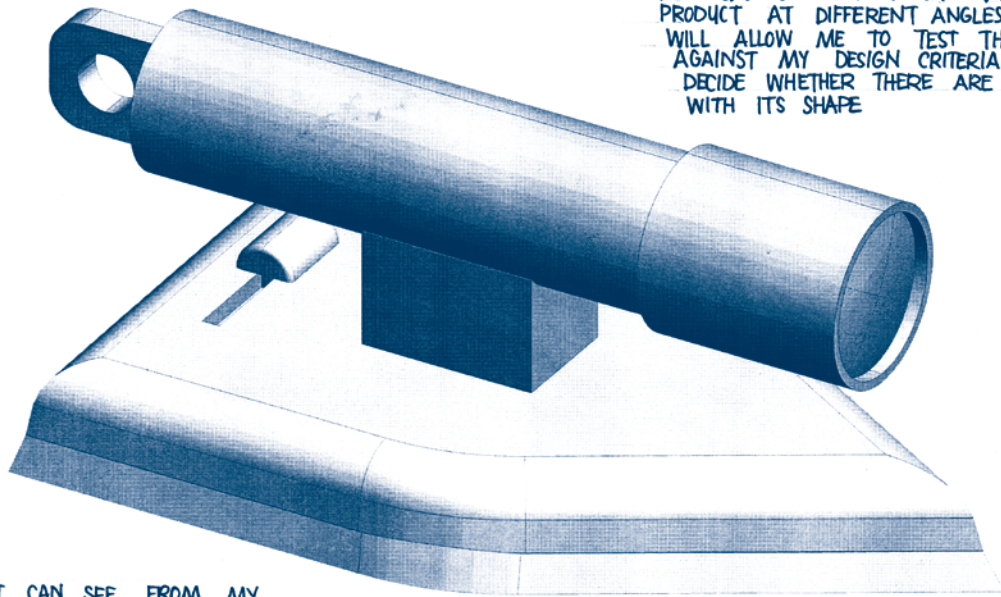

I HAVE MODELLED MY FINAL DESIGN PROPOSAL USING CAD SO THAT I CAN VIEW MY PRODUCT AT DIFFERENT ANGLES. THIS WILL ALLOW ME TO TEST THIS PRODUCT AGAINST MY DESIGN CRITERIA AND DECIDE WHETHER THERE ARE ANY PROBLEMS WITH ITS SHAPE

I CAN SEE FROM MY MODELLING THAT THE BLOCK CONNECTING THE TORCH TO THE SOLE PLATE NEEDS TO BE MOVED TOWARDS THE LENSE OF THE TORCH. THIS WOULD MAKE HOLDING THE IRON MORE COMFORTABLE FOR THE USER.

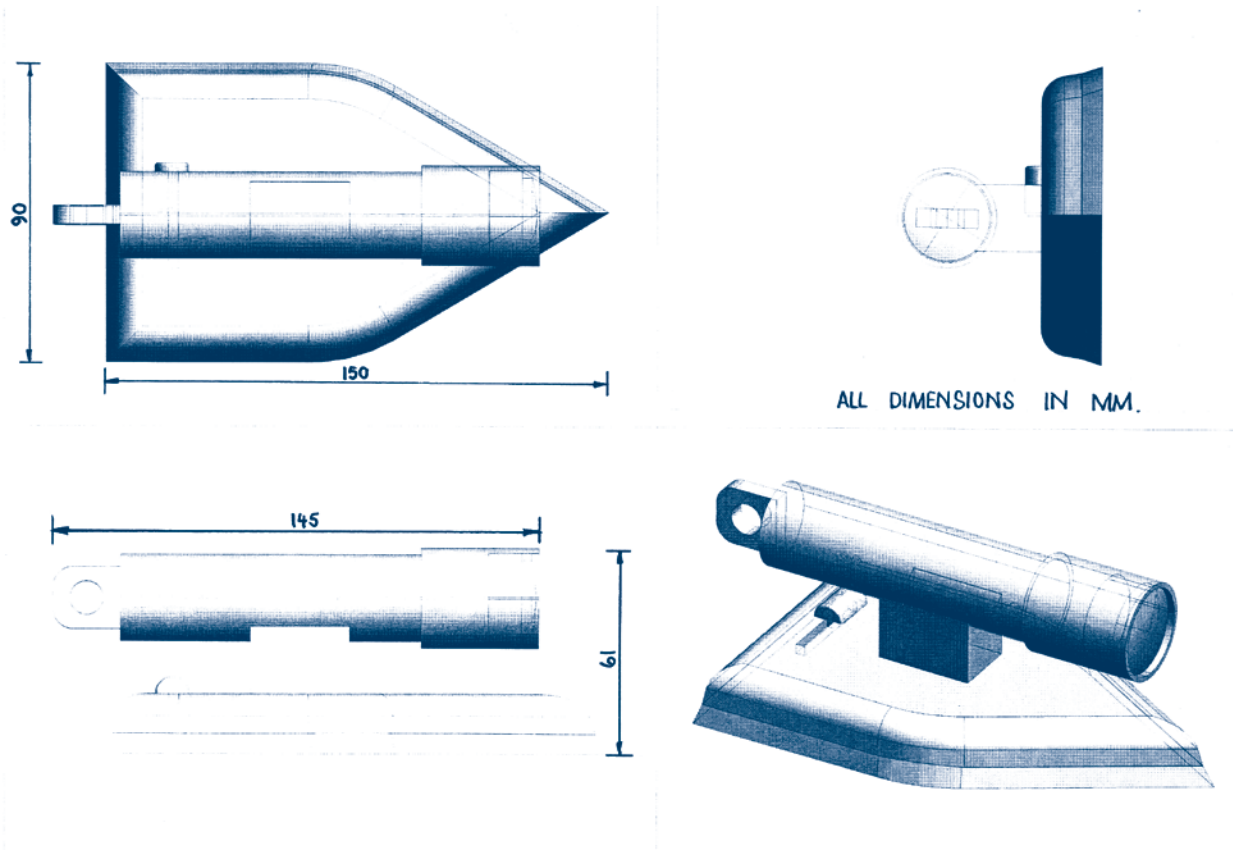
Sheet 5:**Moderator comments: Sheets 4 and 5**

The design is modelled in 3D CAD and some information is gained from this, highlighting a design flaw, and a modification is suggested to overcome this problem. A working drawing is included which indicates the major dimensions of the product.

To achieve the higher level of response, more reference should be made to the design criteria, and how the final design proposal meets them. Full scale modelling using Styrofoam™ would have been extremely useful to get a greater 'feel' of the product and would have proved invaluable in gaining ergonomic feedback and details of proportions for further modification.

Working drawings should be fully dimensioned and complete. Recording conclusions drawn from modelling, and any resulting design changes or modifications, would increase the level of response, as would a detailed objective evaluation of the final design proposal. Comments from potential users would provide valuable third-party feedback.

Recommended websites

The following websites may be useful for students. The list is not definitive, but gives suggestions as starting points for further research.

Please note that while website addresses are checked at the time of publication, website addresses may change at any time.

Unit 1: Portfolio of Creative Skills and Unit 4: Commercial Design

Design analysis

www.bbc.co.uk/schools/gcsebitesize/design/resistantmaterials/designanalysisevaluationrev2.shtml

www.seymourpowell.com

General design interest

www.designcouncil.org.uk/

www.designmuseum.org/design

www.design-technology.info/cwhelp/page10.htm

www.design-technology.info/home.htm

www.lucidinnovation.com

www.vam.ac.uk

www.seymourpowell.com

www.sciencemuseum.org.uk

Unit 2: Design and Technology in Practice

Materials and components

Composites

www.diseno-art.com/tutorials/carbon_fiber.html

www.diseno-art.com/tutorials/fiberglass.html

Metals

http://en.wikipedia.org/wiki/Properties_and_uses_of_metals

www.ndt-ed.org/EducationResources/CommunityCollege/Materials/Introduction/metals.htm

www.tpub.com/air/1-18.htm

Modern materials

<http://en.wikipedia.org/wiki/Electroluminescence>

<http://en.wikipedia.org/wiki/Lcd>

http://en.wikipedia.org/wiki/Luminous_paint

Paper and board

<http://en.wikipedia.org/wiki/Papermaking>

www.biltpaper.com/atoz.asp

www.paperhall.org/info/glossary.html



Polymers

www.bpf.co.uk

www.factmonster.com/ce6/sci/A0839313.html

Smart materials

www.cs.ualberta.ca/~database/MEMS/sma_mems/index2.html

Woods

www.woodbin.com/ref/wood

Industrial and commercial practice

Forming techniques

www.geomembrane.com/TechPapers/CalenderKing.htm

Glossary of engineering terms

www.engineersedge.com/manufacturing.htm

Glossary of graphic design and printing terms

www.designtalkboard.com/glossary/software/a-glossary.php

Graphical communication

<http://technologystudent.com/designpro/drawdex.htm>

Quality

Quality

www.design-technology.info/QAandQC/default.htm

www.schoolforchampions.com/tqm/

www.strategosinc.com/iso_9000.htm

Health and safety

Health and safety

www.healthandsafety.co.uk/haswa.htm

www.hse.gov.uk/legislation/hswa.htm

www.hse.gov.uk/pubns/indg163.pdf

Unit 3: Designing for the Future

Industrial and commercial practice

Biopol®

www.science.org.au/nova/061/061key.htm

Biotechnology

http://en.wikipedia.org/wiki/Genetically_modified_plant

www.usda.gov/wps/portal/!ut/p/_s.7_0_A/7_0_1OB?navid=BIOTECH&parentnav=AGRICULTURE&navtype=RT

EDI, ISDN, LAN, global networks, video conferencing

http://en.wikipedia.org/wiki/Electronic_Data_Interchange

EPOS

http://en.wikipedia.org/wiki/Point_of_sale

Special Effects

http://en.wikipedia.org/wiki/Special_effects

Systems and control

Flexible manufacturing systems

http://en.wikipedia.org/wiki/Flexible_manufacturing

www.uky.edu/~dsianita/611/fms.html

Just in time systems

http://open-site.org/Business/Terminology/Stock_Control/Just_in_Time/

www.strategosinc.com/just_in_time.htm

Robotics and artificial intelligence

http://en.wikipedia.org/wiki/Artificial_intelligence



Design in context

Influences on design history

www.crmsociety.com

www.designboom.com/eng

www.designmuseum.org/design

www.design-technology.org

www.starck.com

www.raymondloewy.com

www.vam.ac.uk

Scales of production

www.design-technology.info/batch/default.htm

www.willamette.edu/~fthompso/MgmtCon/Mass_Production.html

Sustainability

Energy sources

http://en.wikipedia.org/wiki/Renewable_energy

www.eia.doe.gov/kids/energyfacts/sources/whatsenergy.html

Sustainability

http://en.wikipedia.org/wiki/Sustainable_design

www.gdrc.org/uem/lca/life-cycle.html

www.globalissues.org/TradeRelated/Development.asp

Waste management/recycling

http://en.wikipedia.org/wiki/Waste_Management

www.recyclenow.com

www.recycling-guide.org.uk/facts.html

www.rentokil-initial.com/corporate-responsibility/cost-efficiency/environmental-management

Pearson Education Limited is one of the UK's largest awarding organisations, offering academic and vocational qualifications and testing to schools, colleges, employers and other places of learning, both in the UK and internationally. Qualifications offered include GCSE, AS and A Level, NVQ and our BTEC suite of vocational qualifications, ranging from Entry Level to BTEC Higher National Diplomas. Pearson Education Limited administers Edexcel GCE examinations.

Through initiatives such as onscreen marking and administration, Pearson is leading the way in using technology to modernise educational assessment, and to support teachers and learners.

This guide is Issue 2. We will inform centres of any changes to this issue. The latest issue can be found on the Edexcel website: www.edexcel.com

References to third-party material made in this guide are made in good faith. We do not endorse, approve or accept responsibility for the content of materials, which may be subject to change, or any opinions expressed therein. (Material may include textbooks, journals, magazines and other publications and websites.)

Publications Code UA037279
All the material in this publication is copyright
© Pearson Education Limited 2013

For more information on Edexcel and BTEC qualifications
please visit our website: www.edexcel.com

Pearson Education Limited. Registered in England and Wales No. 872828
Registered Office: Edinburgh Gate, Harlow, Essex CM20 2JE
VAT Reg No GB 278 537121