



Pearson

GCE A Level Art and Design

**Art, Craft and Design
Component 1**

GERALD

Total Mark 51 (41 + 10 PS)

	AO1 Develop	AO2 Explore and Select	AO3 Record	AO4 Realise	Personal Study
Mark	10	10	10	11	10
Performance Level	4	4	4	4	4
				Total out of 90	51

Design Brief

As an art student that loves crafting, I love exploring new ideas to help me achieve my final outcomes. I understand in order to get new ideas or develop my design skills, I need to explore and try out new things. The problem is that I notice some young artists (art students) sometimes do not like to stay in the same atmosphere doing things. For example, some young artists like doing things in fresh environments (e.g., parks), some like calm environments (e.g., home), and some like noisy environments (e.g., around friends). Therefore, I will design a "storage organiser" for young artists, which is portable. When the artists feel like the space is suitable for creativity, or get inspirations, they can begin to design using specialist equipment housed in the portable organiser.

In general storage organiser can be big and take up spaces. Therefore, some young artists must take out everything in it, and store them separately. For that reason, I have thought of designing a portable storage organiser, that can be fit into the cupboard of the unique desk, which I'm also going to design.

Overall, I would like to develop my idea, which is to design the storage organiser for young artists, to inspire them to be creative on the move. This will let the art students explore different places, meet new people, and develop their knowledge, which can make their lives more exciting and fun. The design of the unique desk with many features included is designed to encourage the professional users (e.g., young artists) to keep working hard and be creative.

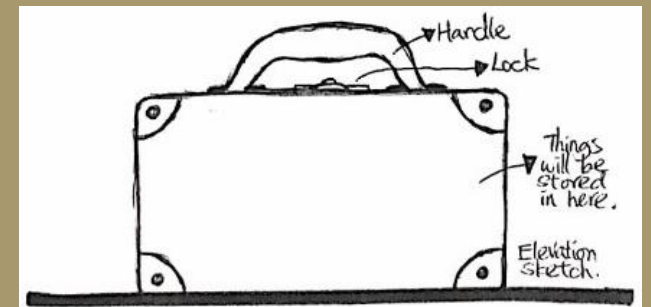
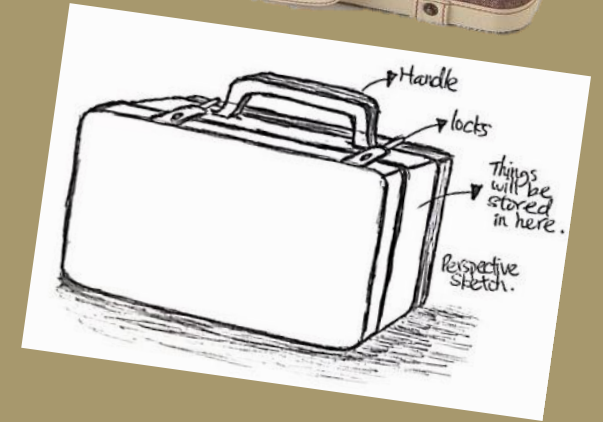
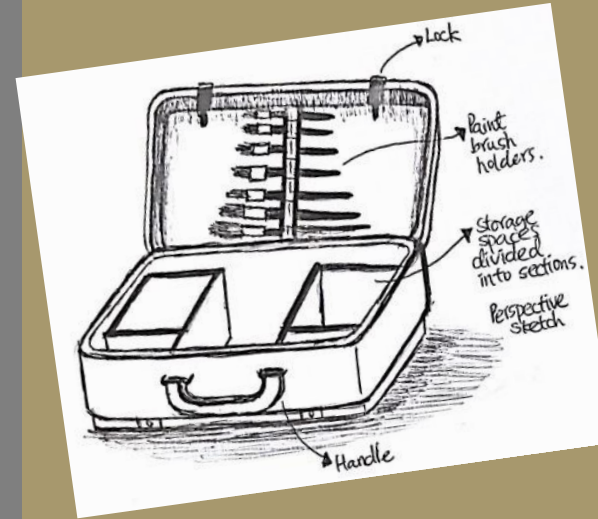

Product Specification

The theme of the products' design is "Natural & Organic".

1) Function: The storage organiser must provide lots of spaces for art supplies (e.g., scissors, pencils, tapes), and materials (e.g., cardboard, felt, paper, wires) to be stored. This means the storage organiser should have layers of storage spaces, for things to be stored in an organized way. The desk should have plenty of features and spaces to store things, including the cupboard to store the storage organiser.

2) Accessories: The storage organiser must have a place where the users can hold or carry, such as crossbody straps, or handles. Also, the storage organiser should have a lock. The desk must have storage spaces (e.g., cupboard, drawers, pencil pot).

3) Size: The size of the storage organiser should not be too big for the users to carry around. It should be around the size of an A4 paper. The size of the desk should be around the size of the normal desk (130cm x 65cm x 80cm).

4) User: Storage Organiser: Art & Design students
Desk: Professional users

5) Safety: There should be no any sharp edges, which can be dangerous for the user, or cause injury to the user. All the edges have to be smooth, to avoid user to get injury.

6) Satisfaction: The product need to be designed in a pleasing way, that suits the user and the environment, and need to be designed in an attractive and eye-catching way.

7) Materials: The storage organiser should be made using the lightweight and strong materials, as it will need to store things, and the user need to carry it. The desk should be made using strong and hard materials, as it will need to have the strength to hold many things.

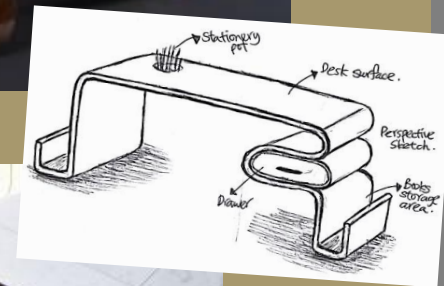

Primary Research & Collage Technique

Redesign the everyday products that I use.



The green hat will light up, and there will be a warning alert sound, when it sense an unusual/strange person, trying to steal the keys.

When the user click the "Green" button (structured on the handle), the handle will disappear, and return inside the purse.

The patterns on the ice-cream cone will light up, when they sense something unusual around, such as a stranger.



Functional button that will open the bottle's cap.

Functional button that will open the bottle's cap.

Cap is opened.

Cap is opened.

This a handle, which the user can use to hold the purse.

A bell is structured in the croissant, which will start ringing when someone holds the keys, or when there is a movement, which can cause the bell to shake. This can give an alert to the key owner, that someone has touched the keys, or is trying to steal the keys.



A piece of sun resistant sheet will roll out from here.

When the weather is really hot & sunny, the user can press the button on the highlighter, and a large piece of sun resistant protector sheet will roll out, to protect all the other stationeries. This will prevent the sun heating up all the stationeries, and cause the inks to dry.



The structure being placed on top of Donald Duck's bow is the structure that the user twist, in order to let the tissue roll out.

Tissue paper will roll out from here, when the user twist the structure on Donald Duck's red bow.



These are grips. There are grips attached on both sides of the pencil case, placed in the same position. A long piece of grip is also attached onto the bottom of the pencil case.

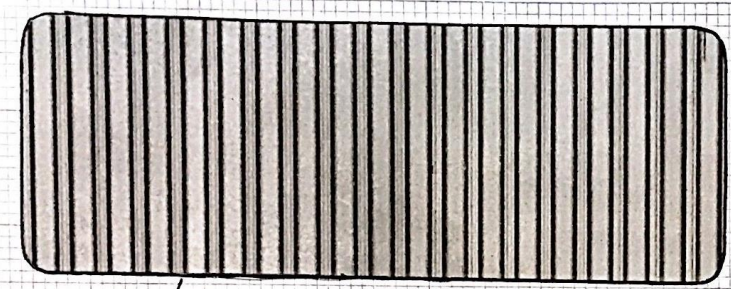

This grip design is going to be attached onto the bottom of the pencil case, to prevent the pencil case from slipping.

Platinum Jubilee's Flag



Street sign



Stop button



Street guide



Mapping My Journey



Underground sign



Streetlights



Street sign



Bus handles



Traffic light



Street sign

"To & From College"



Construction sign

Reflect on positive designs' aspect to my journey.

Street guide

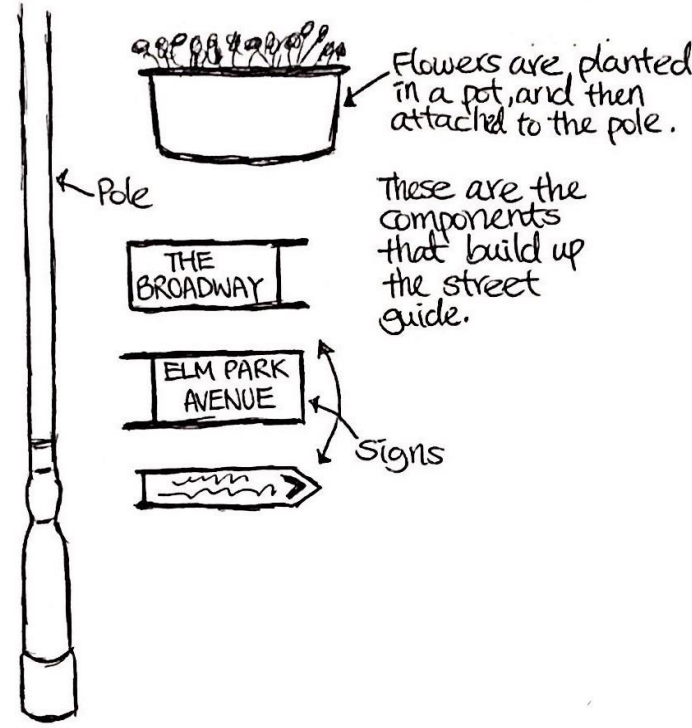

Positive features:

The street guide can direct people on the directions of the places they want to visit.
The second feature is that the design of a flowerpot on the street pole can brighten up the atmosphere, and it is a smart design, as it saves up spaces, rather than putting a bunch of flowerpots on the ground.

Stop button

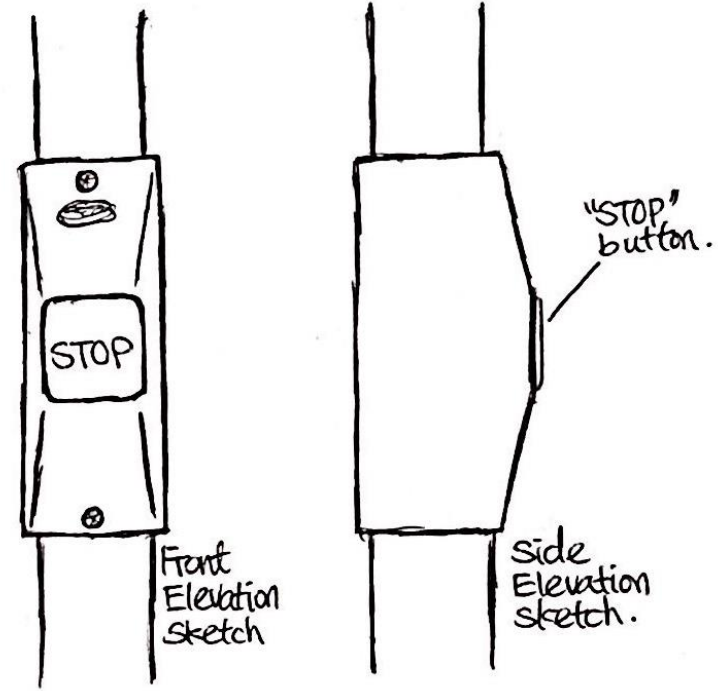

Positive feature:

There are "stop" buttons in the interior of the bus, along the walkway. Therefore, customers can get the chance to press the "stop" buttons, when they want to get off the bus, as there are "stop" buttons along the walkway. This is a great design, as the customers would not get stressed about how to tell the bus driver to stop the bus. Also, the design of the "stop" button is to avoid customers having a conversation with the bus driver just to say, " the bus should stop on the next bus stop", which can break the driver's concentration, and be dangerous.

Street sign

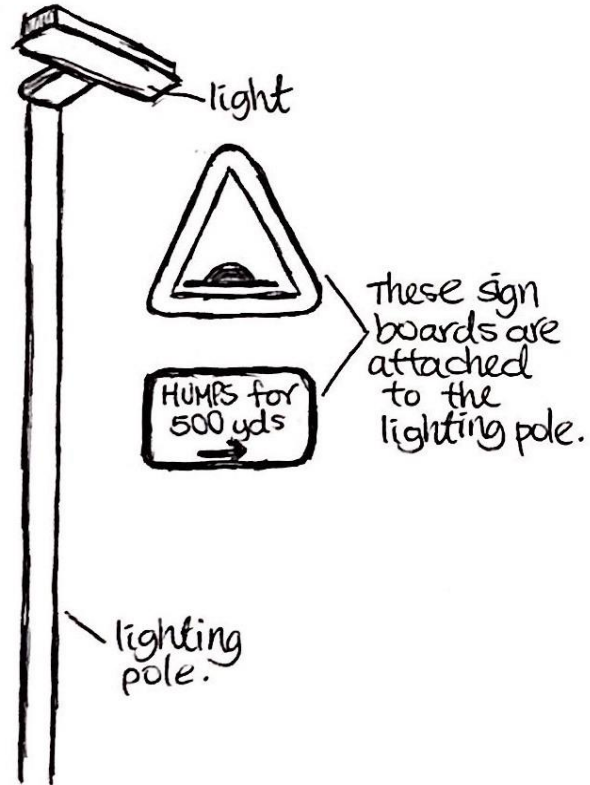

Positive feature:

It is great to design a lighting above the traffic sign, as when the day turns dark, it may get difficult to see the traffic sign. Therefore, constructing a lighting above the street sign can give the drivers the chance to see the traffic sign, and prevent any accidents.

Pedestrian Crossing Button

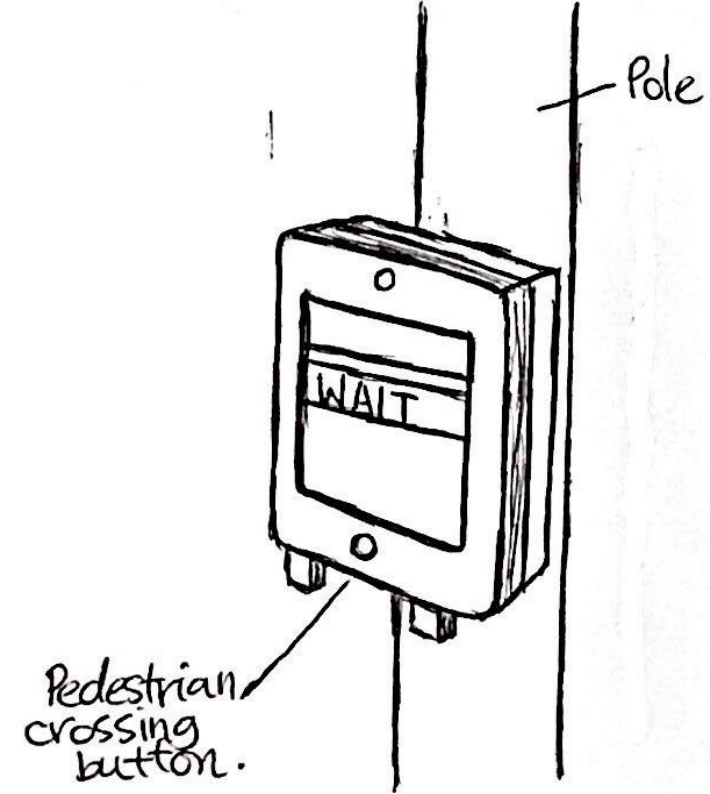

Positive feature:

When you want to cross the road, you can press the "pedestrian crossing button", and wait for a signal to appear from the opposite side. There will be a signal ringing, and a green man's light will light up from the opposite side of the road, to tell you that you are safe to cross the road. This is a smart design, which can guide people, and reduce the chance of having any traffic accidents. This design also shows consideration towards the people that are walking, which is crucial, as everyone's lives are significant.

Reflect on negative designs' aspect to my journey.

The construction sign



Problem:

Putting the construction sign on the walkway is dangerous. The reason is that the sign blocks nearly half of the walkway, and this makes it harder for people to walk pass, and there is a drive-way next to the walkway, therefore, some people will have to walk on the driveway. That's very dangerous, and this might cause some accidents.

My Design of the

"Construction Sign":
After learning about the negative aspect of the construction sign, I have created a new idea for the construction sign that is taller and looks thinner, rather than being wider and blocking the walkway.

Curly stripes around the pole. The stripes will light up in yellow colour at night, to give people a warning.

Elevation Sketch

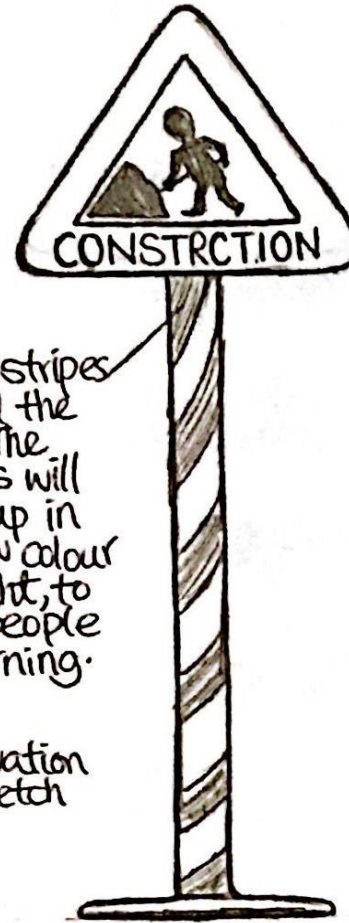

Solution:

I think the construction sign should be made taller, and be structured together with a tall street pole. So this will reduce the chance of the walkway being blocked. Also, this can make it easier for people to walk past the construction sign, as the walkway is not blocked.

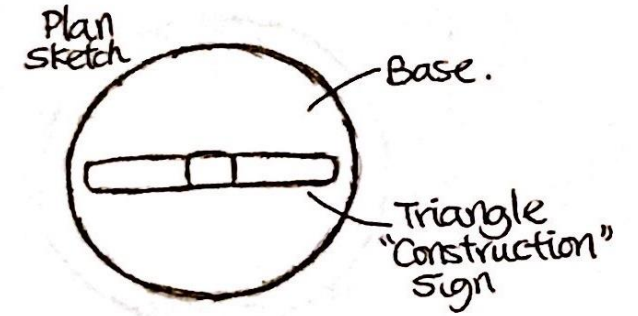

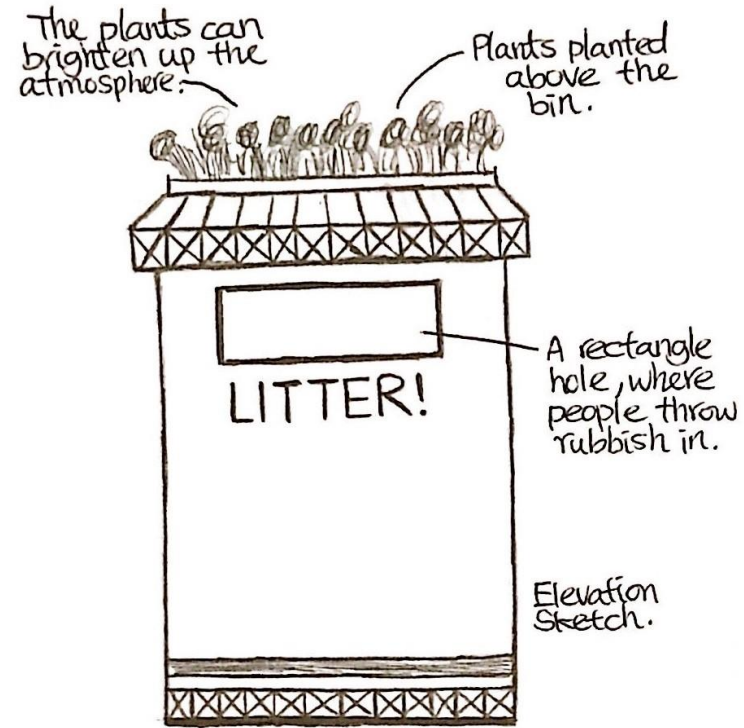
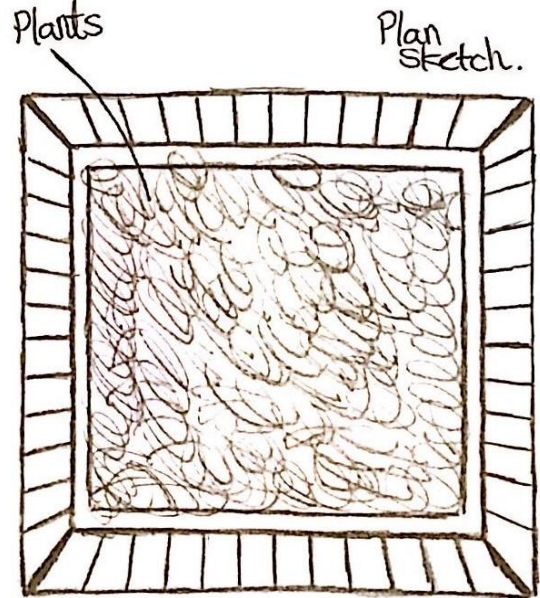

My Design of the "Rubbish Bin":
 After learning about the negative aspect of the area around the pavement, I have created a rubbish bin, which will be placed on the pavement to encourage people to throw rubbish in the bin, rather than on the floor.

Traffic light



Problem:
 Sometimes, I see people throwing rubbish in the tiny pavement section, which is designed in the middle of two roads. It can be dangerous to throw rubbish in the pavement section, as the wind can blow away the rubbish, and may cause accidents. For example, if there is a shopping bag on the pavement, the wind can blow it on to the road, or may blow it in front of the car's windscreen, this blocks the driver's view, and may cause accidents.

Solution:
 I think a rubbish bin should be constructed beside the traffic light, on the pavement section. This can give people the chance to throw their rubbish in the bin, rather than throwing them on the pavement.



Yanko Design: Project 1, Mark Mitchell's Suitcase

Mark Mitchell is a British Designer, who produced the idea of a smart useful design of a suitcase, that will make it easier for travellers to pack and unpack things, while travelling to different places, and hotels.

The suitcase is designed in a way that you do not have to unpack everything when you arrive a place, and then repack them when it's time to leave. This suitcase has lots of features, for example, there are sections built in the drawer that is constructed in the suitcase, so you can pull out the drawer when you want to find things. Under the drawer, there is a big section, where you can store your things, such as clothes. Another feature is that the suitcase is being opened and closed, like a cabinet with zips around, which is easier to open, rather than laying down the entire suitcase to find stuff.

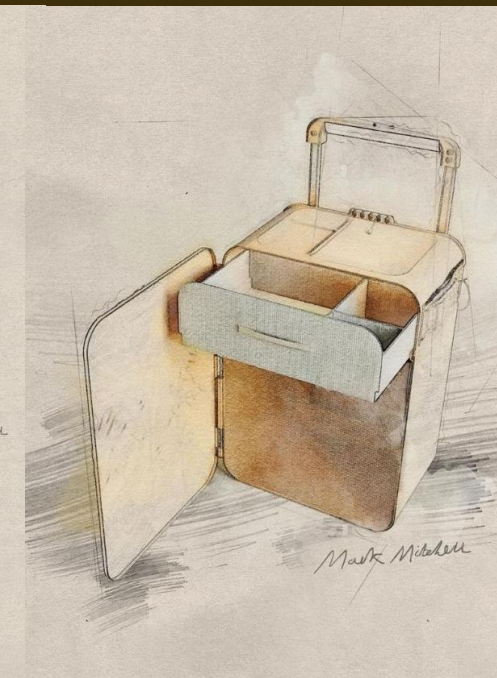
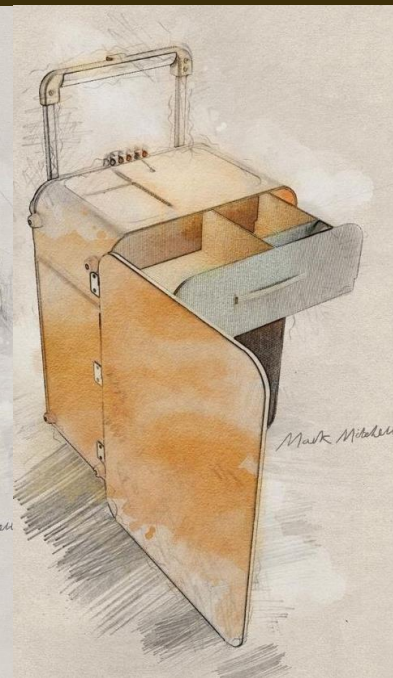
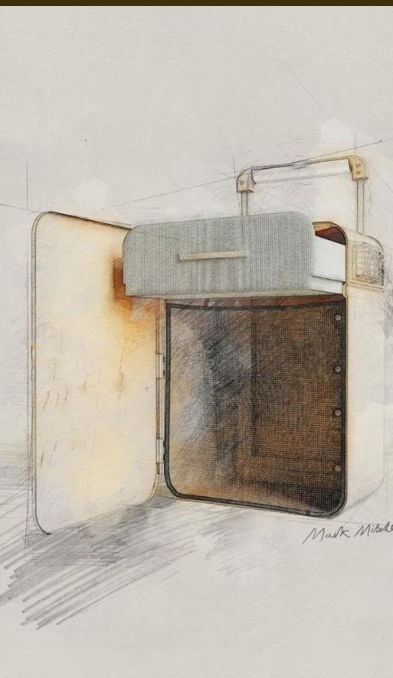
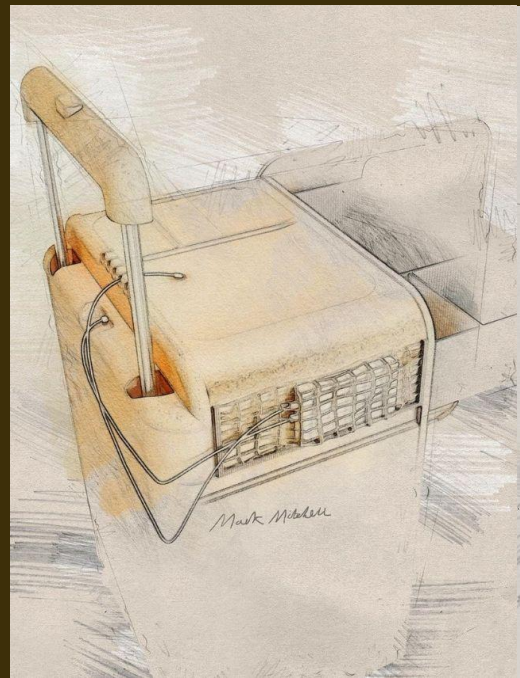

The suitcase is suitable to be placed beside your bed. The reason is that it can serve as a bedside table with lamp around the handle. If you plug in an external battery pack, the handle will light up, and serve as your bedside lamp.



I like Mitchell's suitcase design, as just one single suitcase can make up so many features, which can make travelling a lot easier. I think Mitchell's suitcase design has inspired me to design something unique with many features in one. I have travelled to lots of places, and have not seen this kind of design before, which is a smart idea. When I am older, I am still going to travel around the world. Therefore, if I become a "Product Designer" when I'm older, then I am going to design some useful products with many features in one single product, which can save up spaces, and make life a lot easier.



Yanko Design: Project 2, The Office Table By: Pedro de Sousa

Pedro de Sousa is a detail-oriented Graphic Designer with over 15 years of experience. He had experienced lots of different designing skills in the society, such as Branding, Corporate Identity, Editorial Design, Image Edition, Advertising and Packaging. He has developed a passion for furniture and architecture, which have allowed him to extend his skills beyond into the 3D Visuals production industry.

Pedro de Sousa has designed an office table that comes with different levels and surfaces. The table is made of wood, that is curved around the edges, so there are no sharp points. There are four shiny gold material legs, that appear to be piercing the panels diagonally.



Gaps to store different kinds of objects, including books, stationeries, desk accessories and more.



The office table looks special and elegant. The table has different levels and surfaces. The main tabletop is where people place their laptop and monitor, keyboard, and mouse. There are more spaces to store objects and documents. For example, on the left-side, there are extra levels to store objects. On the right-side, there are also extra levels to store objects. The longer one that extends to the right can function as a monitor stand. It can also be a place to store more books. There is a high level of space on the right, where people can position a lamp, which can make it easier to work in a bright area. The office table is suitable for workers to use, such as students, employers, working from home users, and lawyers.



When I looked at the design of the office table, I can sense the creativity from the designer, to make the table unique. For example, designing diagonal legs with different heights, rather than the common straight legs. There are many pieces of structures attached to the main table in different levels, which make me feel like building a design using Lego pieces. The reason is that people can use Lego pieces to build anything, and whatever they want from their own creative mind. I really like the design of the table, with structures layered on top of another in different directions, with gaps between the layers for people to store things. Some gaps are thinner, and some are thicker, so that different objects can be stored. This can save up a lot of spaces, and this makes it easier for the people to organise and find their stuff.



4 Potential Ideas for My Project

Backpacks



Users	Products
Tourists (Travellers)	A range of backpacks for entertaining and busy lifestyles.
Teenagers with mental disorders (e.g., emotional, phobia, depression)	A range of stress release products.
Art & Design Students	A range of storage organisers. (e.g., Crafts storage organiser)
Professionals	A range of working furniture.

Fidget



Head Scalp Massager

Storage Cart

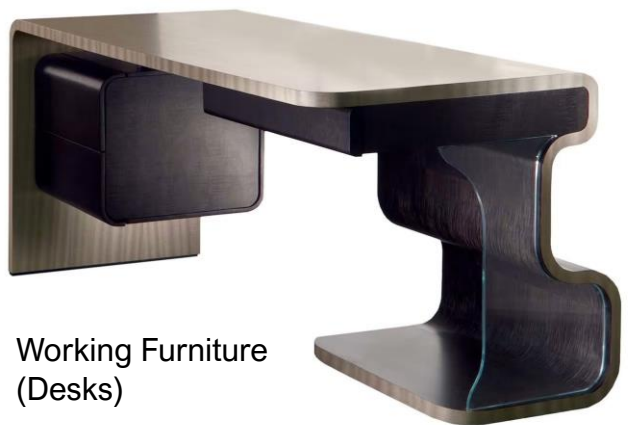

Working Furniture (Desks)



Craft Storage Organiser



Storage Plastic Baskets





**The Two Ideas
for My Project.**

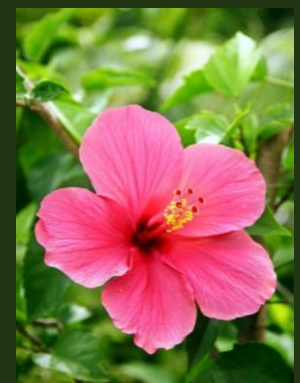
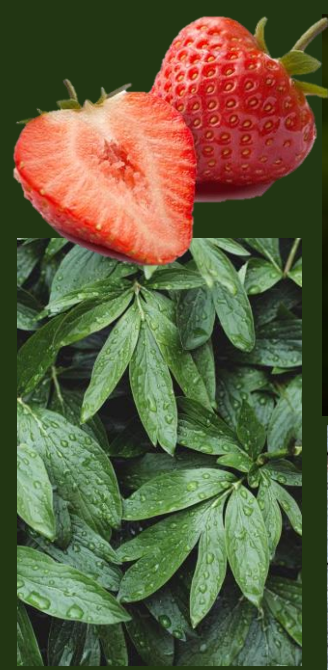

**Theme:
Natural & Organic**

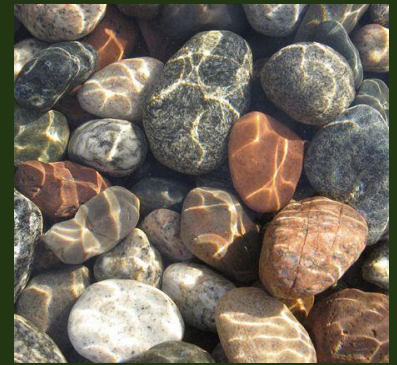



Secondary Research: Idea 1

User: Art & Design students
 Products: A range of storage organisers.



Marie-Jeanne V
 Atelier de Catherine Molinatti



© studio-gul.se

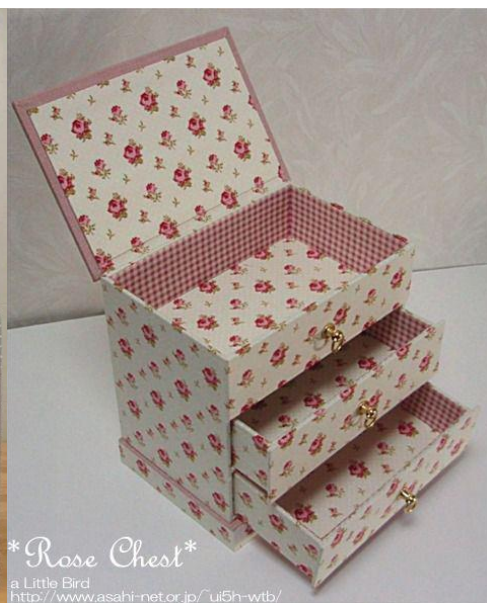

Rose Chest
 a Little Bird
<http://www.asahi-net.or.jp/~ui5h-wtb/>



in my
 own
 style

Secondary Research: Storage Organiser 1

This “crafts’ storage organiser” has inspired me to also design a storage organiser, but with more functions, and considerations toward the users, and also design into my own style. For example, I love making crafts, so I understand that it is important to make a storage organiser with many parts and characteristics, which can make it easier to find stuff (e.g., equipment).

In this design, I like the part that just a single storage box can organise and store the materials and equipment in a neat & tidy way. I also really like how there are two layers of storage spaces, which you can pull up to find another storage space. This is a smart design and can save up a lot of spaces, rather than storing things outside the storage organisers, which can be difficult to find when you need them.

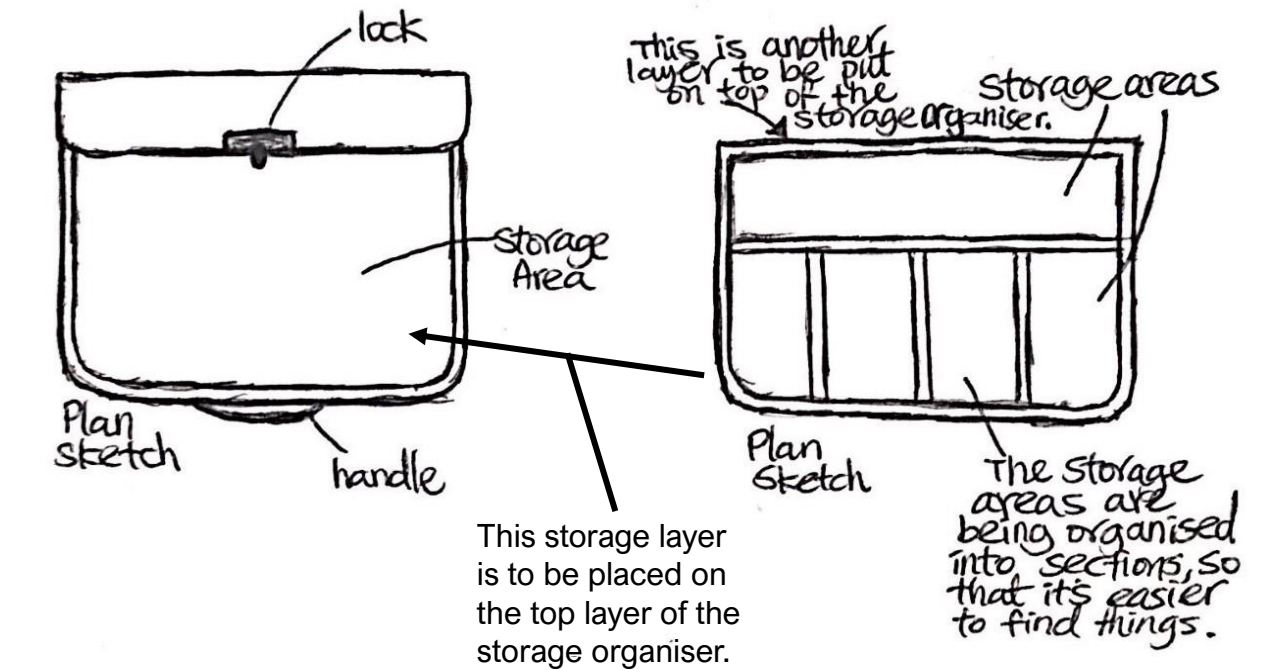
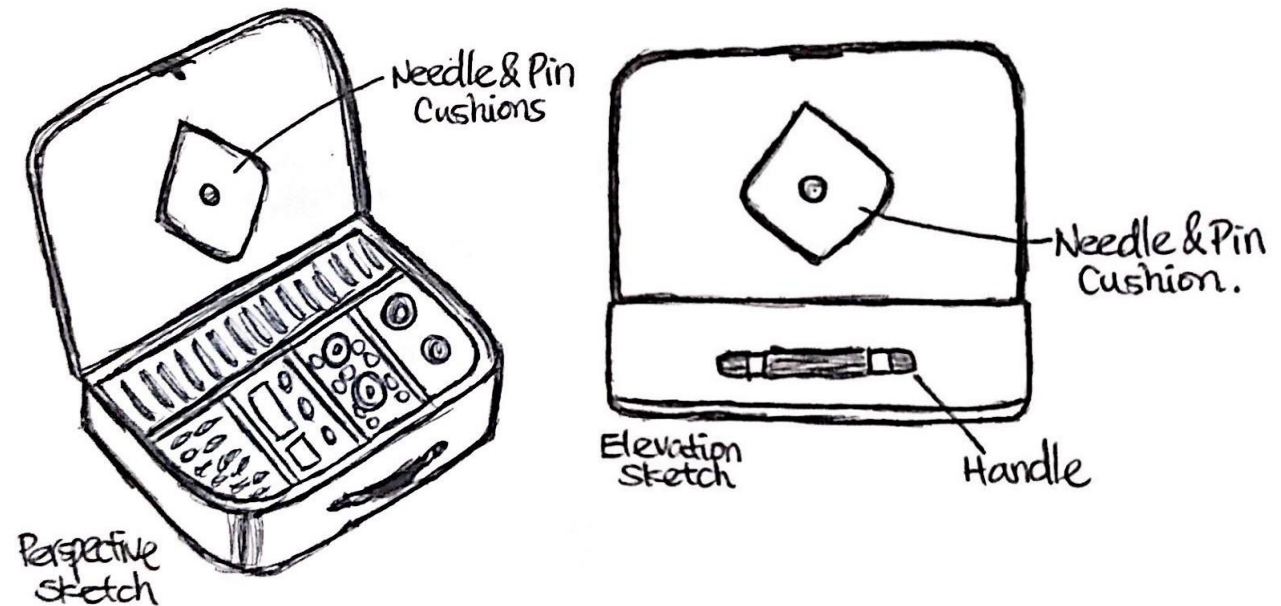

Experience on Storage Organiser 1's Developments

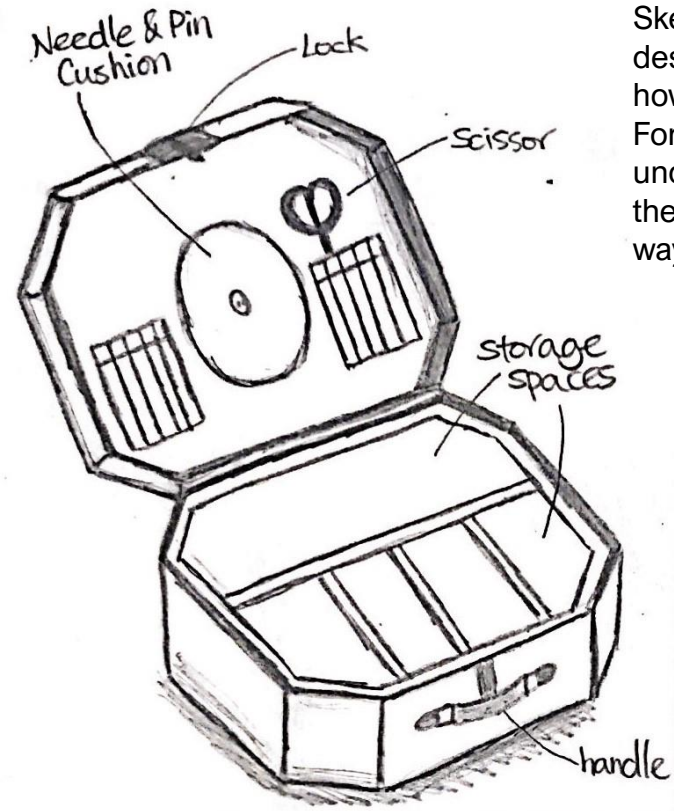

Sketching out and developing these designs have made me understand how to design a storage organiser. For example, I have started to understand that I can also design the storage organiser in a fashion way in many kinds of styles.

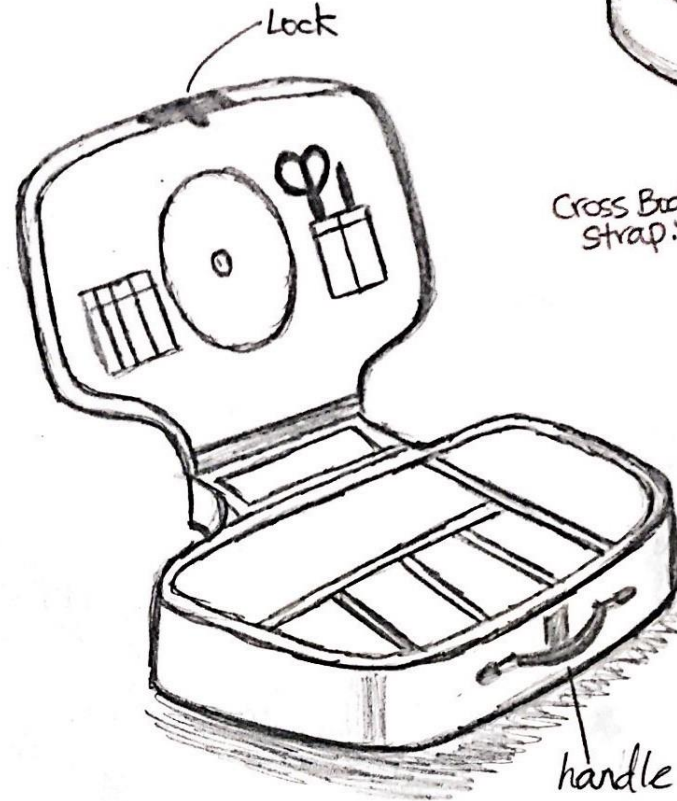

I have developed the original design of the storage organiser 1 into something more interesting with more characteristics. For example, I have added two pieces of fabrics on both sides of the needle & pin cushion, where scissors, pens, and other equipment can be stored.

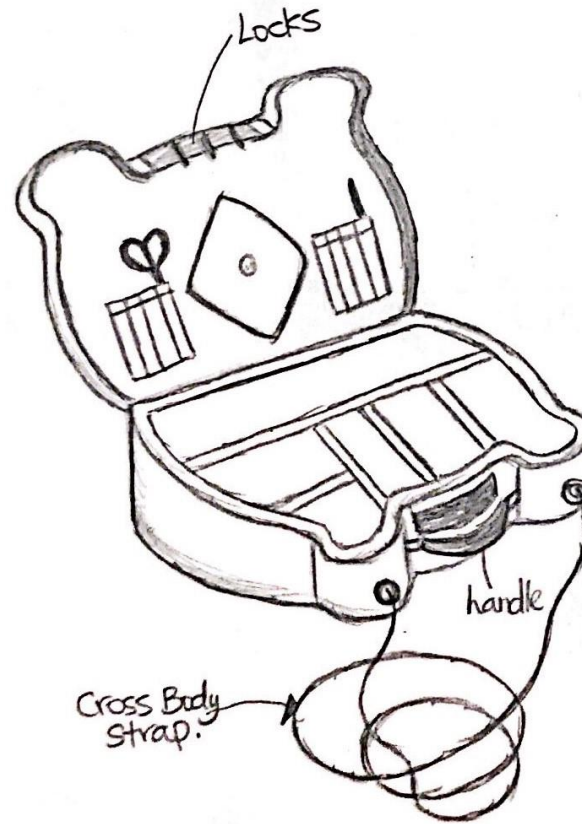

I have developed the shaping of the organiser into a cross-body bag's style, which people (women or men) can carry. This makes it a lot easier for people to carry when there is a lot of stuff in the organiser.

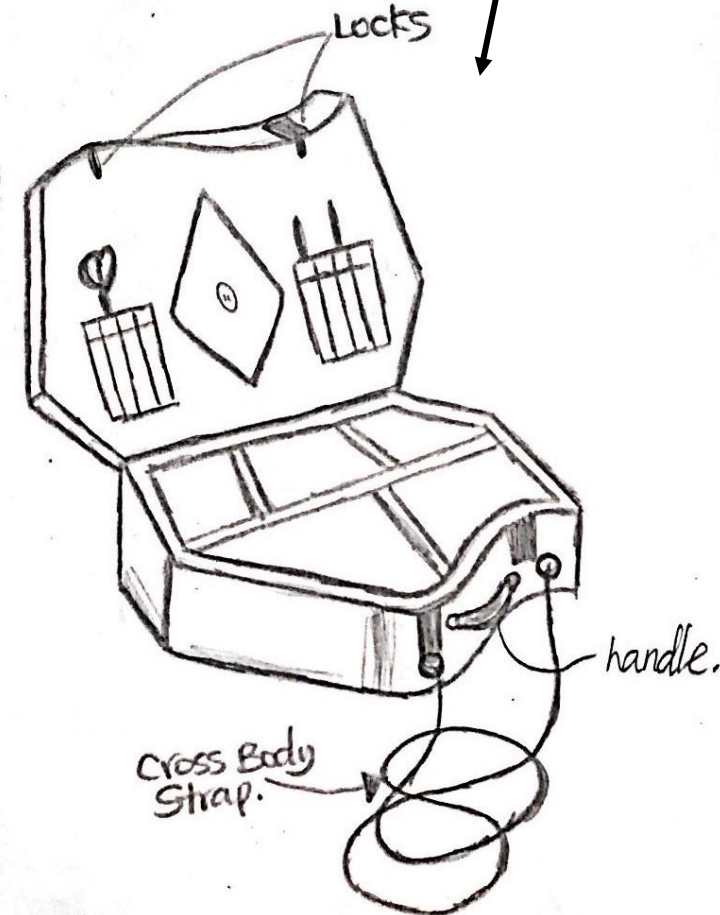

Secondary Research: Storage Organiser 2

In this crafts storage organiser, the way it is designed looks simple and neat, and there are many features in it, which makes it a lot easier to store and find stuff. The design of the handles mean that the people can carry the organiser wherever they want. Also, designing handles are great and that shows consideration towards people, as the handles make people be able to carry the organiser easily.



Sketching out the design of this storage organiser helped me develop understanding on how the organiser function, and how it is structured. This can then help me with the process of designing my storage organiser.

The storage layer can be taken out, and there are more storage spaces underneath it.

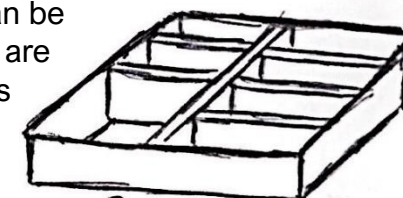

Perspective sketch.

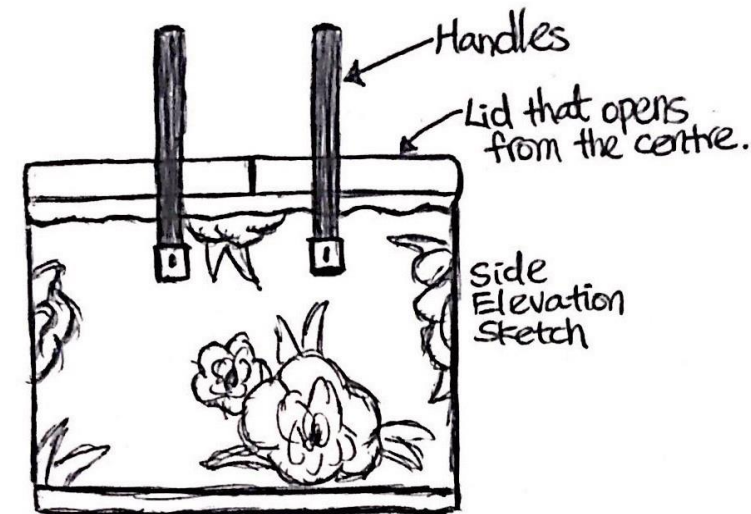
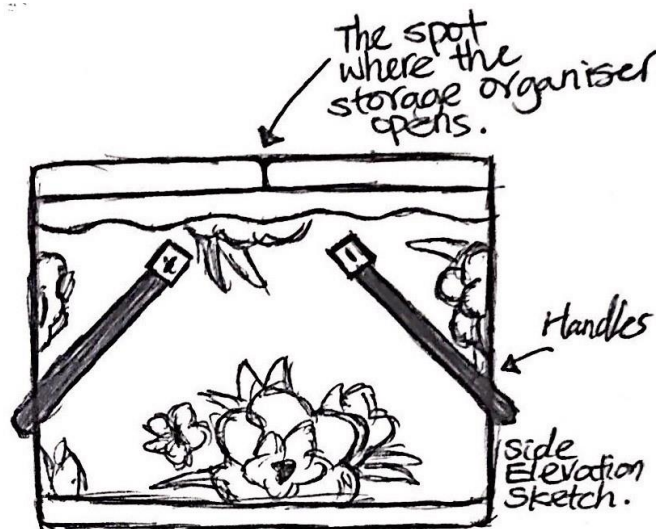
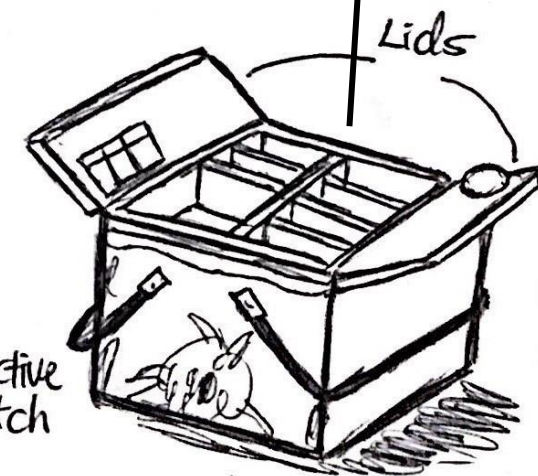
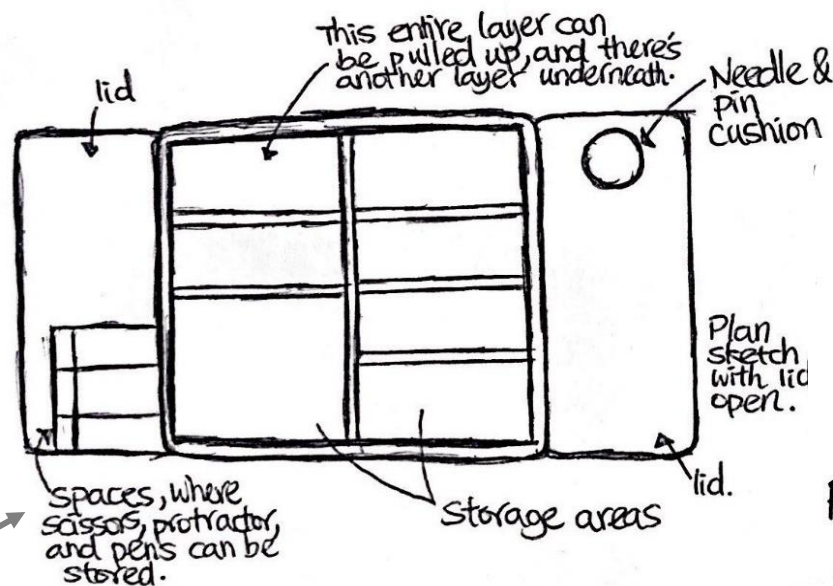

Experience on Storage Organiser 2's Developments

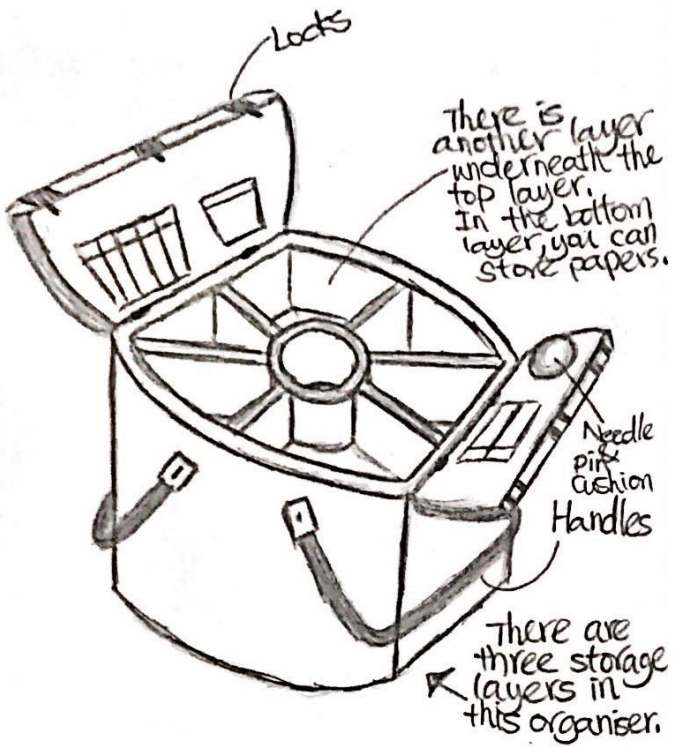

This design has two curved lids, as the whole product is in a design inspired by the flower's shape, which has curved parts.

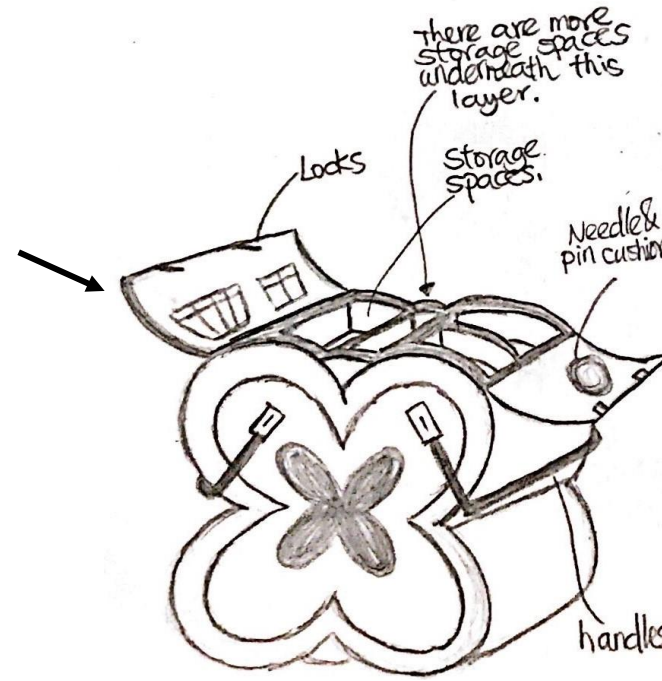

When I was sketching all of these developments, I started to understand how the shapes of the organisers work, and how to save up spaces, and also how to design an organiser that can store things in an organised way. Understanding these concepts allow me to design a useful and smart organiser, which can bring benefits to the art users.

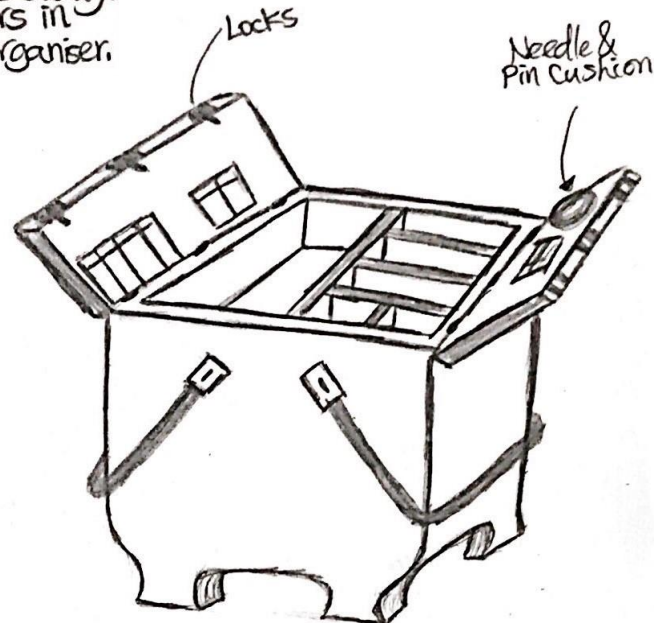

I have developed the shaping of the original storage organiser 2 into more exciting shapes, such as flowers, geometric shape (stone/diamond shape), and a design that has four legs.

In each and one of these organiser design, they all have layers of spaces to store stuff, some are thin layers, and some are thick layers. Also, some spaces are divided into tiny parts to store small materials/ equipment. It is easy to bring out the layers to find the things that the users want. Designing the spaces into sections make it easier to organise and find stuff, rather than having a huge storage space and putting things randomly.

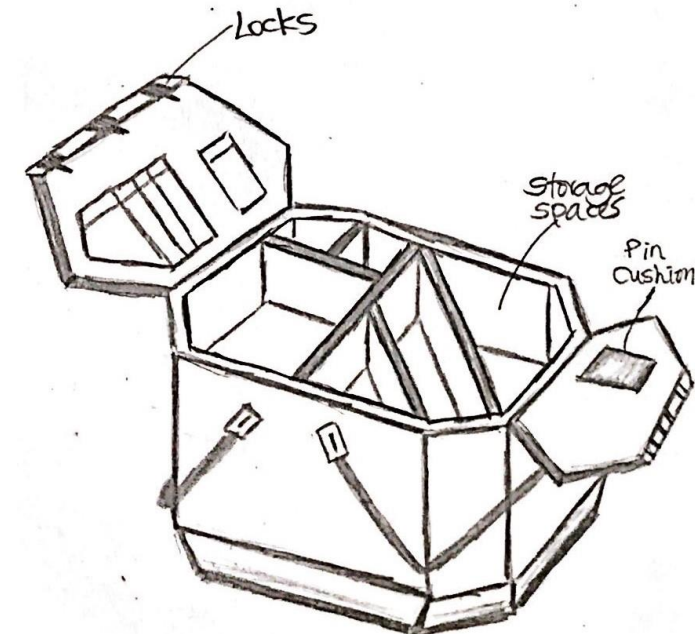



Primary Research: Natural & Organic

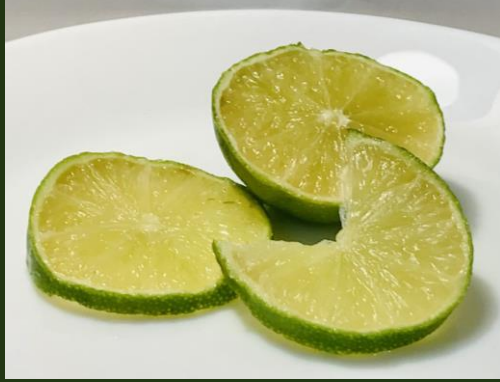

Ideation: Generating Ideas for Storage Organiser Designs

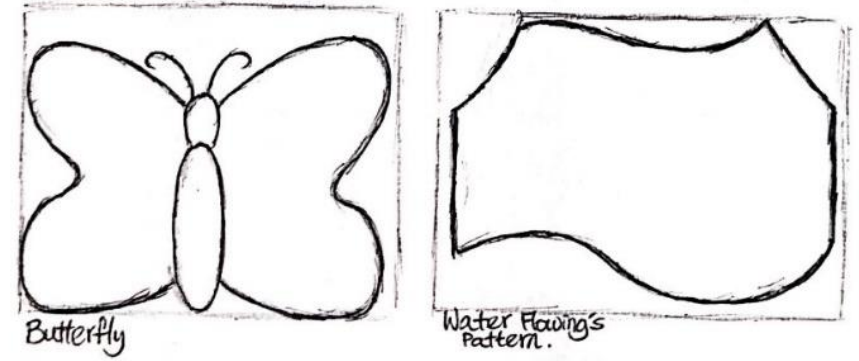
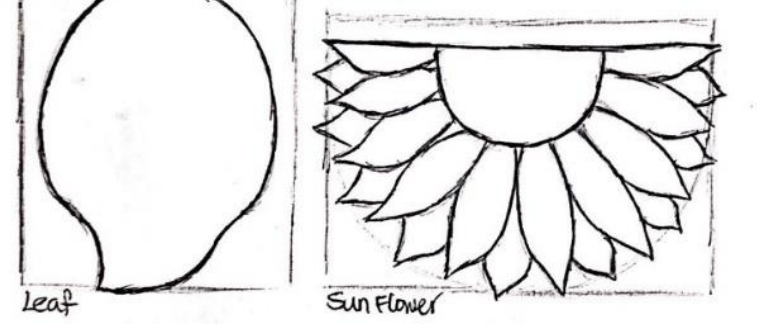
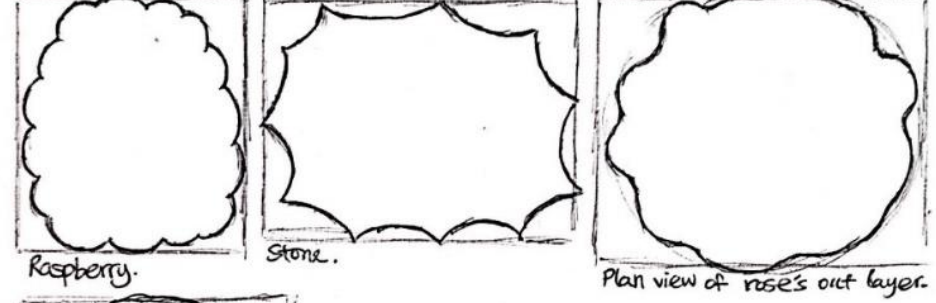
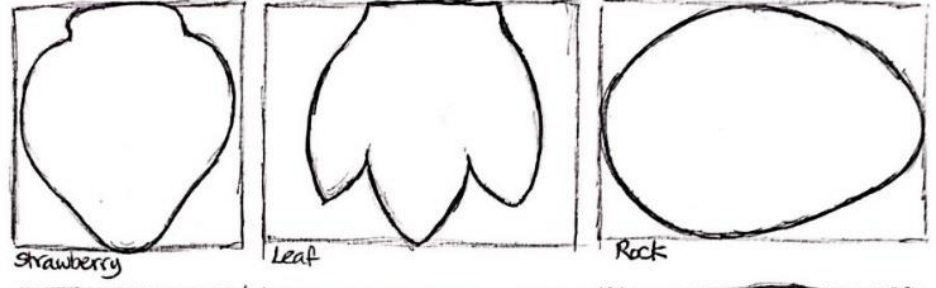
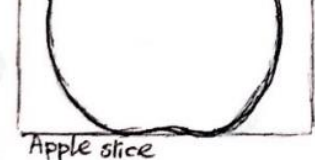
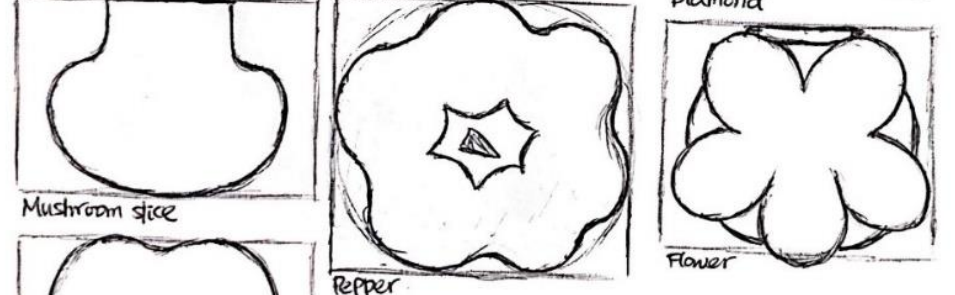
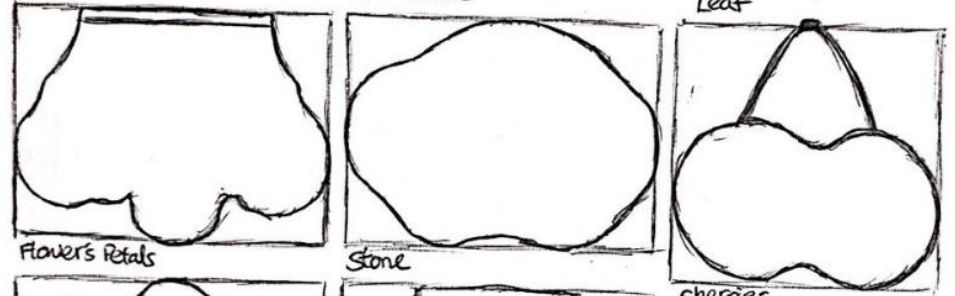
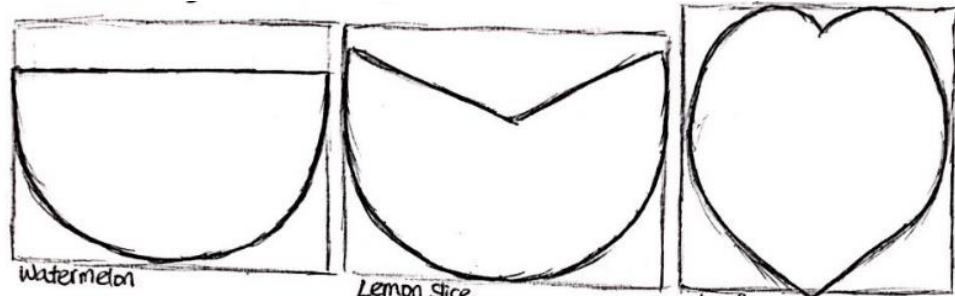

I have roughly sketched out the shaping of "natural & organic" objects. For example, I have sketched out the elevation shape of half of the sunflower. Another example is that I have sketched out the elevation shape of the watermelon slice.

While sketching these shapes, I started to think about how I could link these shapes to the design of a storage organiser, which is what I'm going to design.

Ideation: Developing Ideas

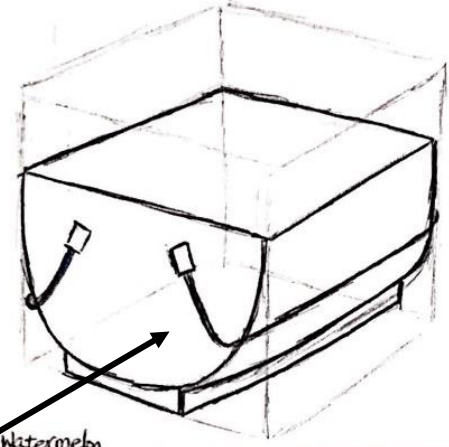

Watermelon

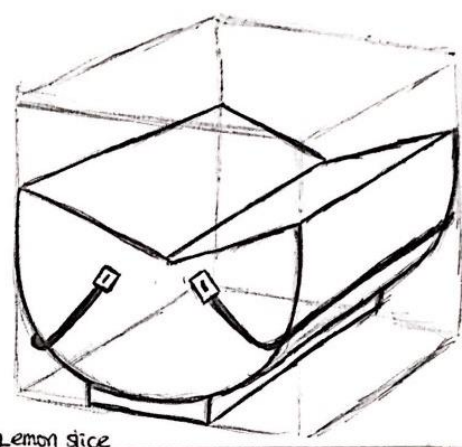

Lemon slice

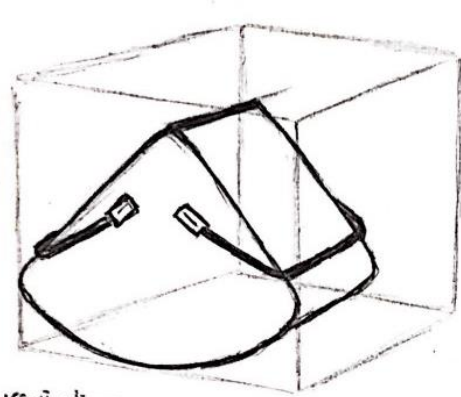

Kiwi slice

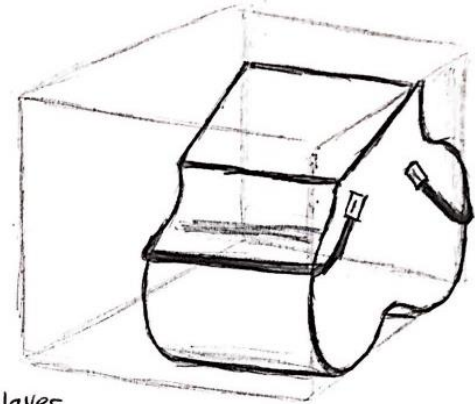

Waves

Handles

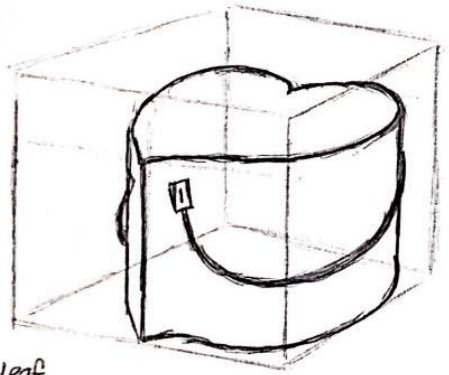

Leaf

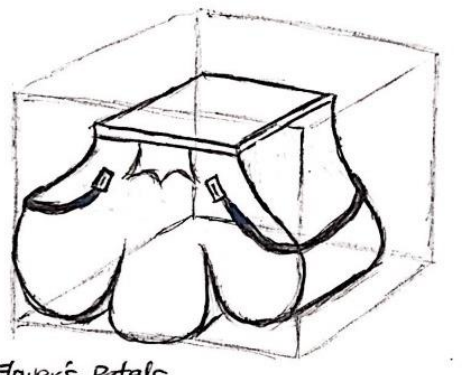

Flower's petals

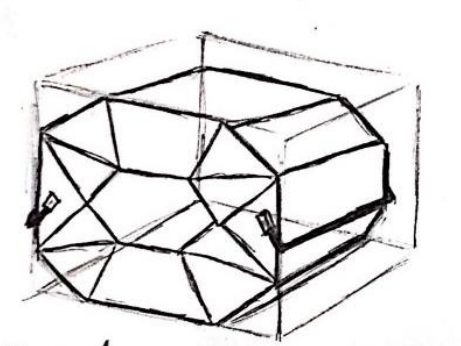

Diamond

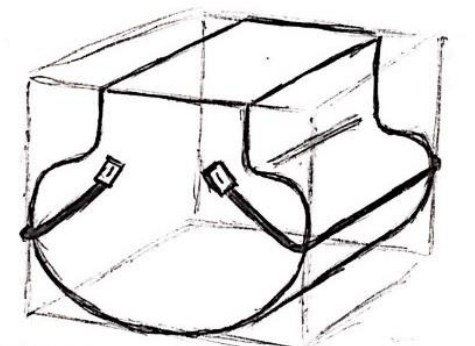

Mushroom

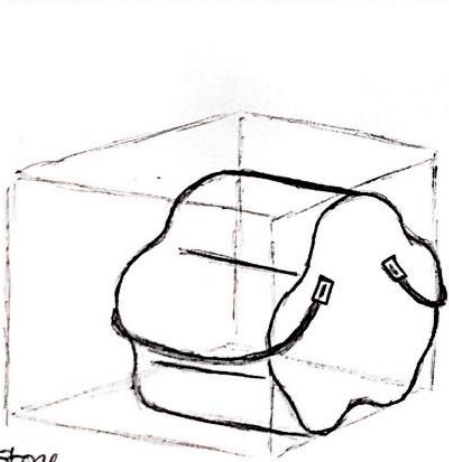

Stone

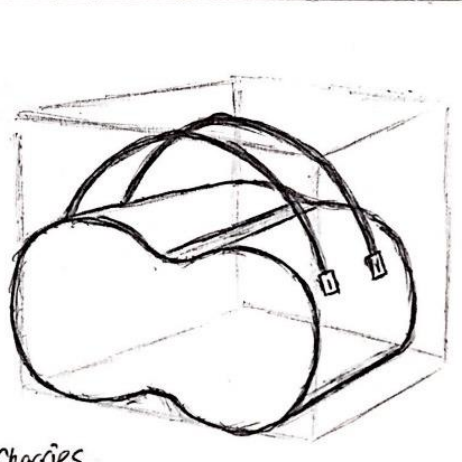

Cherries

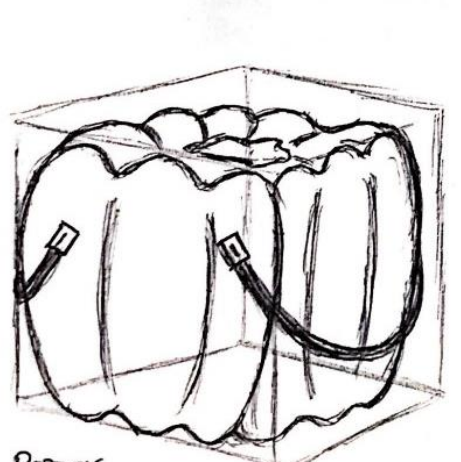

Pepper

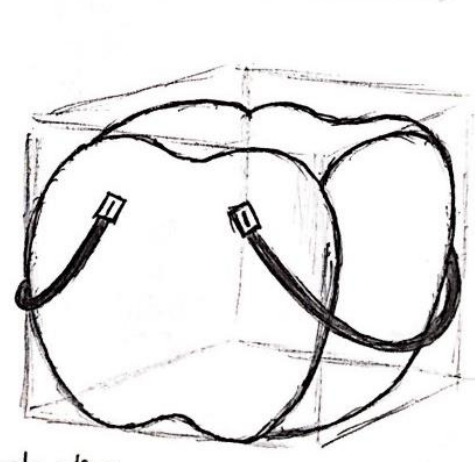

Apple slice

I have sketched out the shaping of the "natural & organic" objects into 3D forms. I tried to turn the ideas that I have generated into basic 3D forms, and I have also thought about how the shapes are going to work.

Ideation: Developing Ideas

I have sketched out the shaping of the “natural & organic” objects into 3D forms. I have started to think about how the shapes are going to work, and where should I design them to make them look unique. For example, some of the “natural & organic shapes” are shown on the sides, so people can see it while the user is holding it. Another example is that some “natural & organic” shapes are shown on the top in a plan view. When I was sketching these 3D shapes, I have tried to sketch out different forms, for example, some 3D shapes are curved, some are wavy, some are straight, and many other patterns.

Going through all these thinking, I have started to gain more knowledge on developing the shapes of the storage organiser, rather than keeping it in a cube shape. These knowledge can help me in the next stage of development.

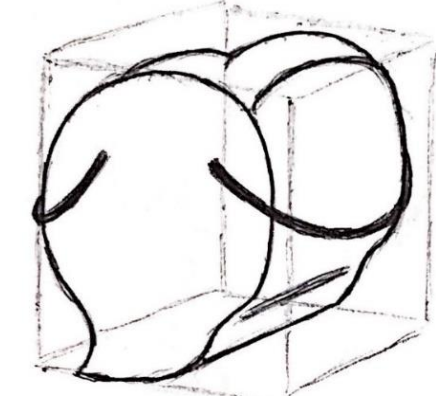

Leaf

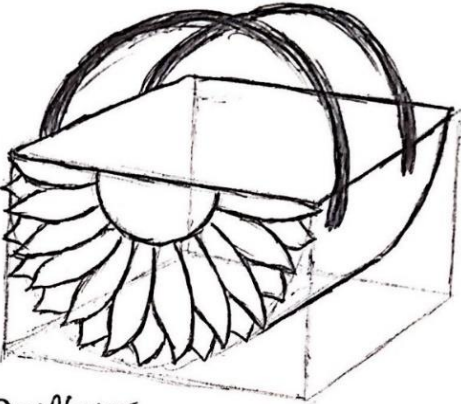

Sunflower

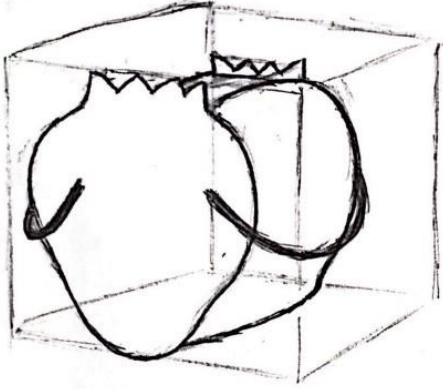

strawberry

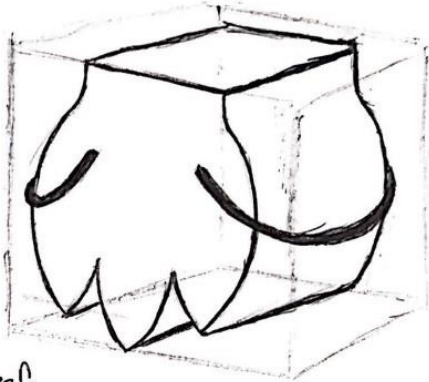

leaf

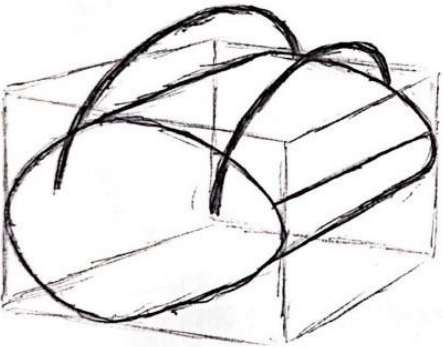

Rock

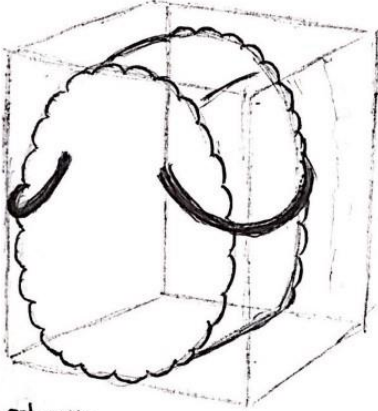

Raspberry

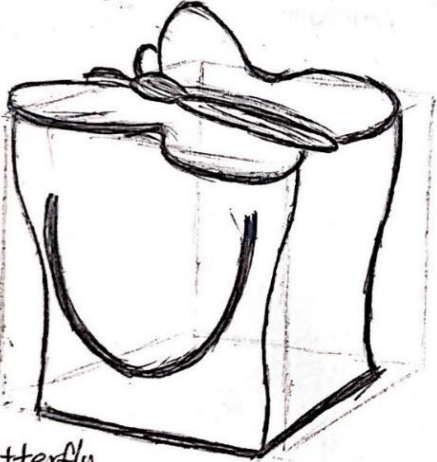

Butterfly

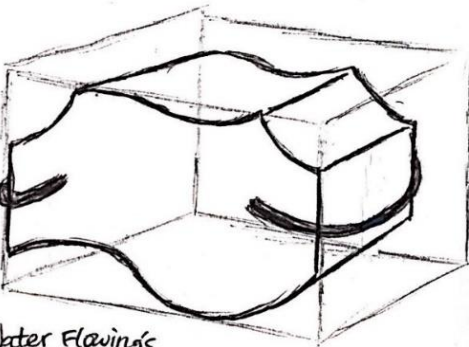

Water Flowing's Pattern

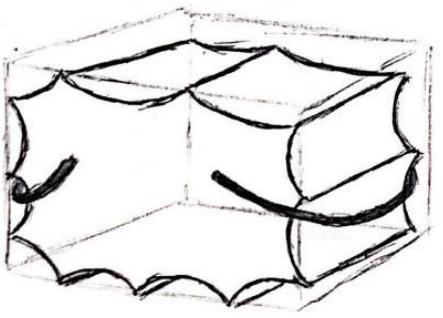

stone

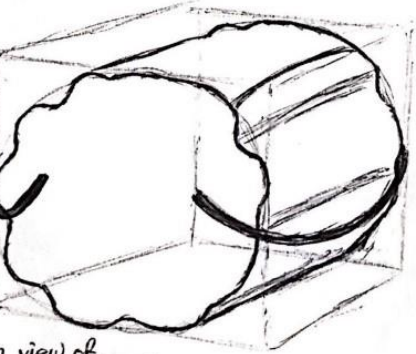

Plan view of roses out layer.

Models: Prototype

(I have made some models to test and see if the ideas work, and if I need some changes.)

Model 1

This design is inspired by the shape of the “lemon slice”. I have made this model using cardboard, empty paper roll (curved card), paper straw, and white foamboard.

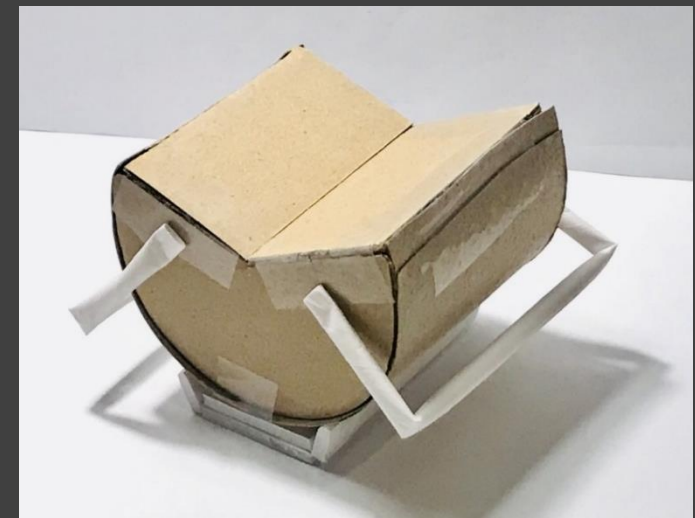
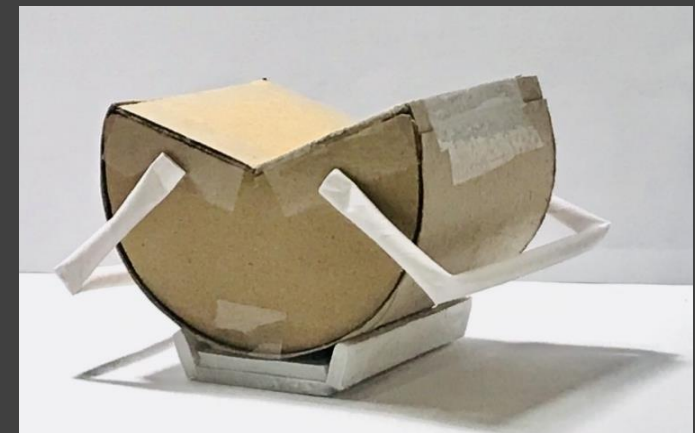
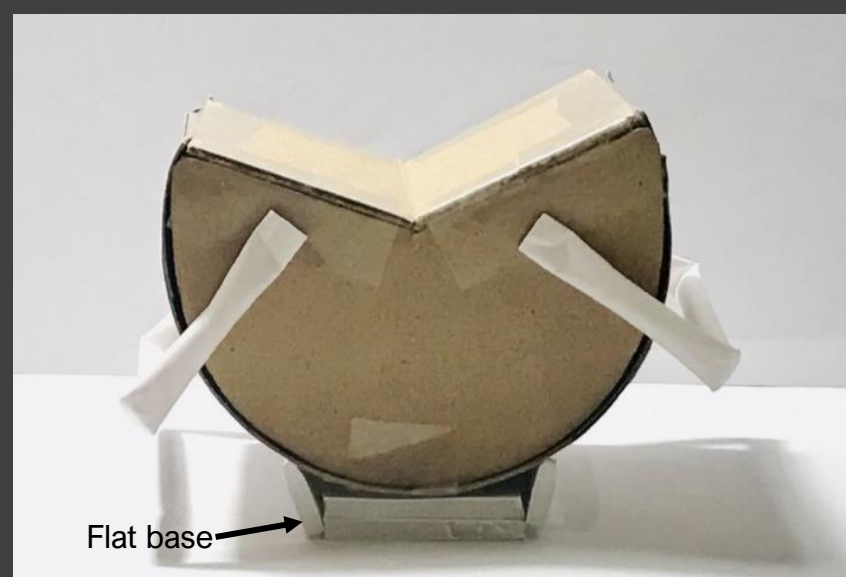
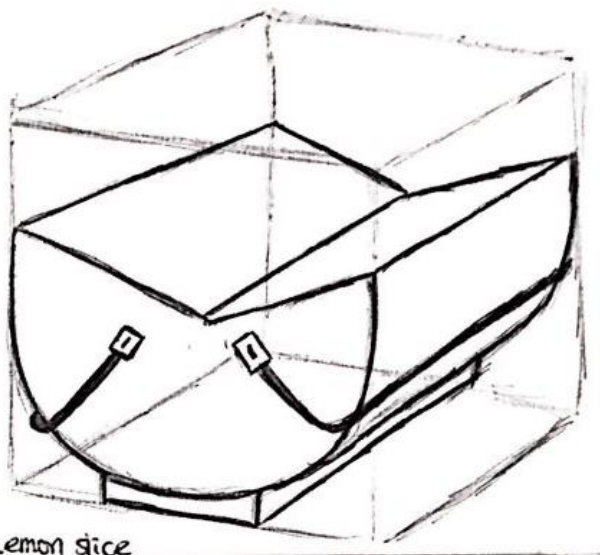

Model 2

After I have experienced making these models, I have started to understand the ways and methods that I can use to improve my designs. For example, while I was making these models, I realised that in order to make a curved product stand on the table, I can design a few waving patterns on the bottom of the curved surface (e.g. design on the right), and make those patterns suit my product design. The other way is that I can design some thin or thick flat line/lines on the bottom of the curved surface to make the product stand.

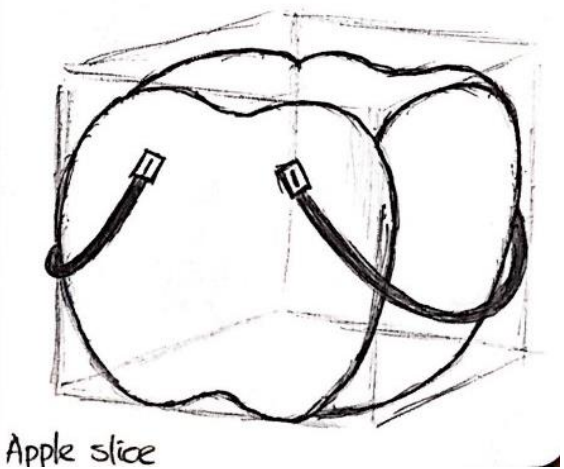

This design is inspired by the shape of the "apple slice". The material that I have used to make this model are cardboard, white foamboard, and empty paper roll (curved card).

Handles

Curved base

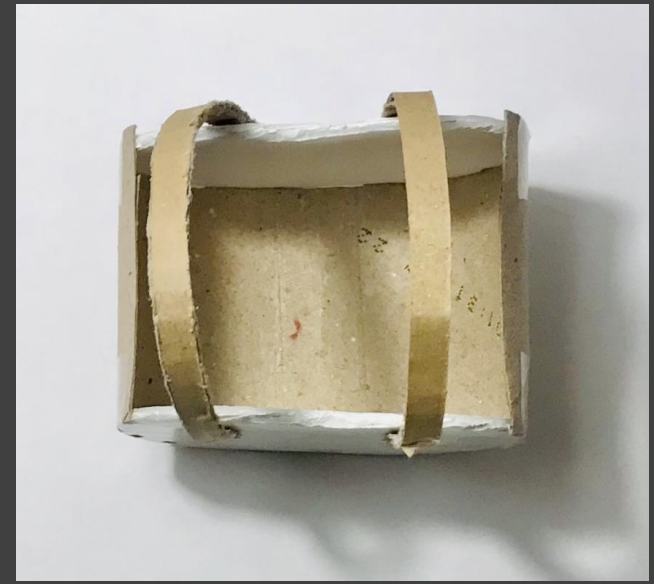

Developing My Favourite Designs

(By adding details, and make some critical thinking about where and how to design the features)

Design 1: Inspired by Sunflower

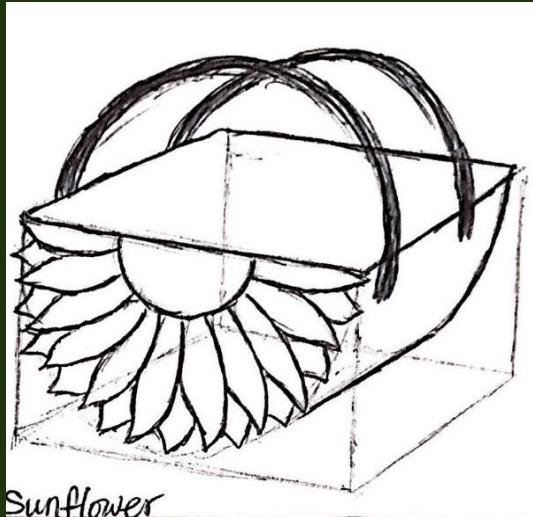

I really like the sunflower design, which looks elegant, and beautiful. However, I have realised that the sunflower design has a curved shape on the bottom, and it would be impossible to make it stand. The reason is that the curved bit will let it move around, without being stable, which will be hard to use and open the organiser. Therefore, I have decided to redevelop the design into an organiser that can stand-up by itself.

I have redeveloped the base (bottom) by making it flat on the centre, and curved on the sides, which can still form a curve shape, but with a flat bottom, so that the organiser will be able to stand by itself.

I have redeveloped, and made some improvements to the design, so that it will be easier and more comfortable to use. For example, I have designed a place on the top where the organiser can open. I have also thought about how the interior space of the organiser is going to be organised, to make it neat and easy to find things.

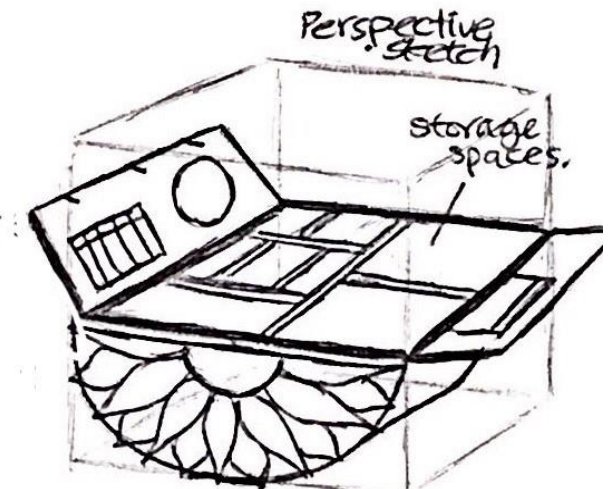
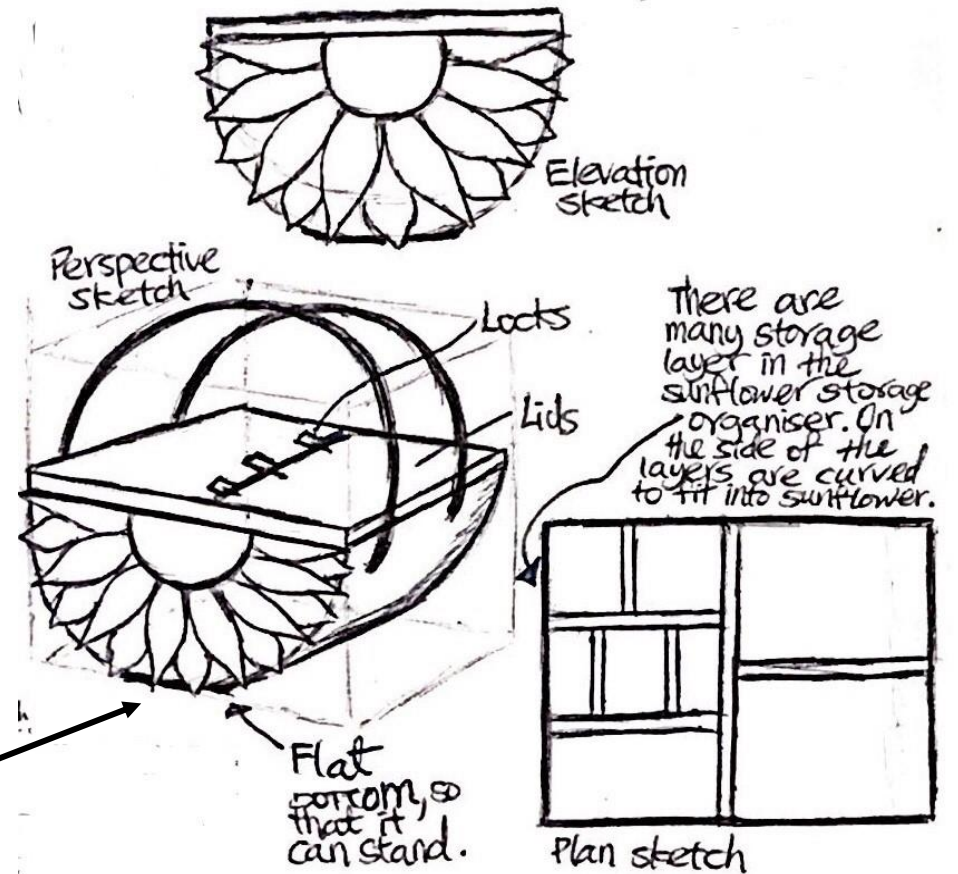

Design 2: Inspired by Sunflower



I have explored by trying to design different shapes for the sunflower design.

The design on the right is designed in a circular shape, and the entire sunflower shape can be seen, which looks great. I have designed a cross-body bag strap onto the design near the handles, so that the users can have two options to carry the organiser whenever they want. For example, sometimes when they get tired, they may want to carry the product using a cross-body bag strap, which can be easier to carry. I believe that the design on the left will have more spaces to store things, and be much easier to carry than Design 1.

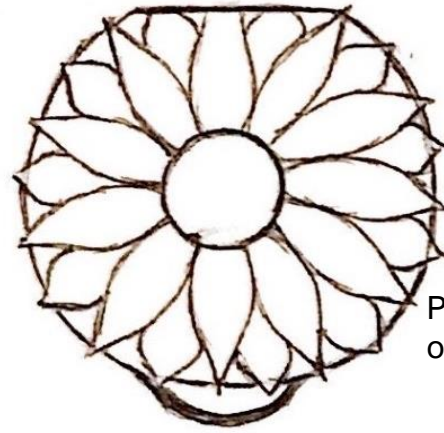

Plan Sketch
of the exterior

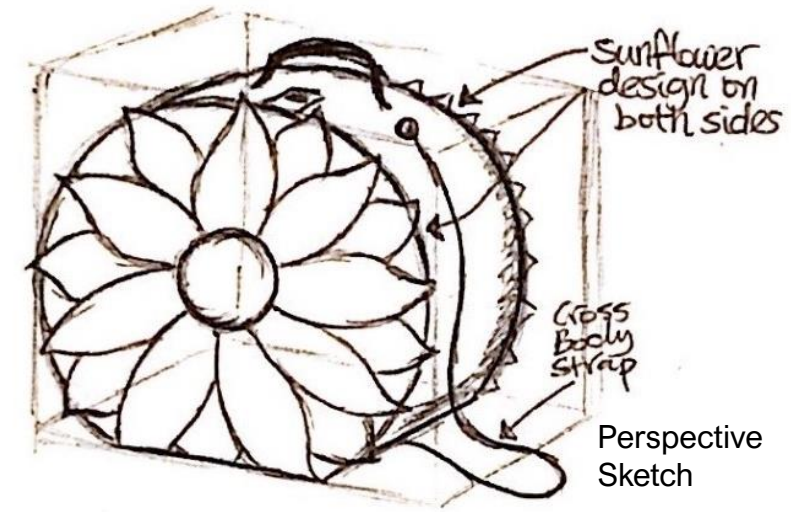

Perspective
Sketch

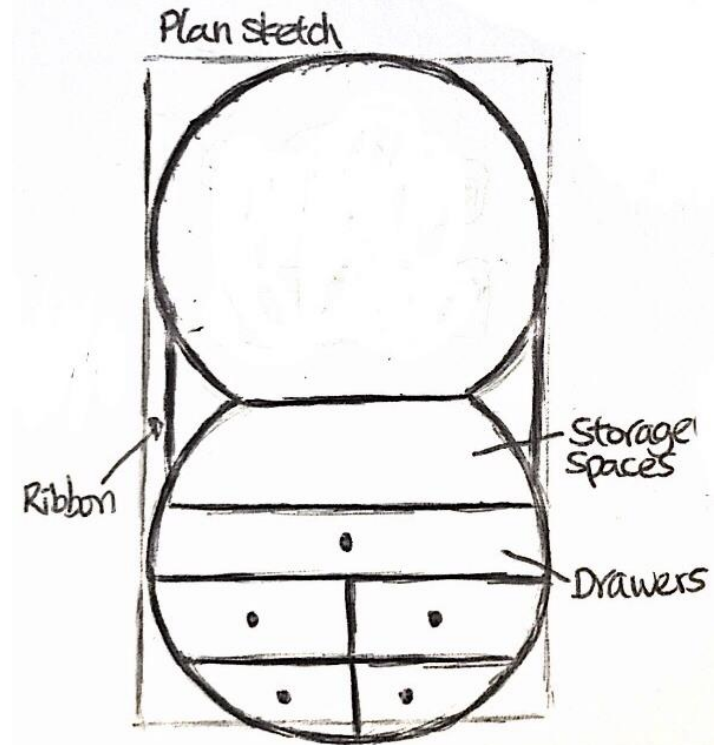
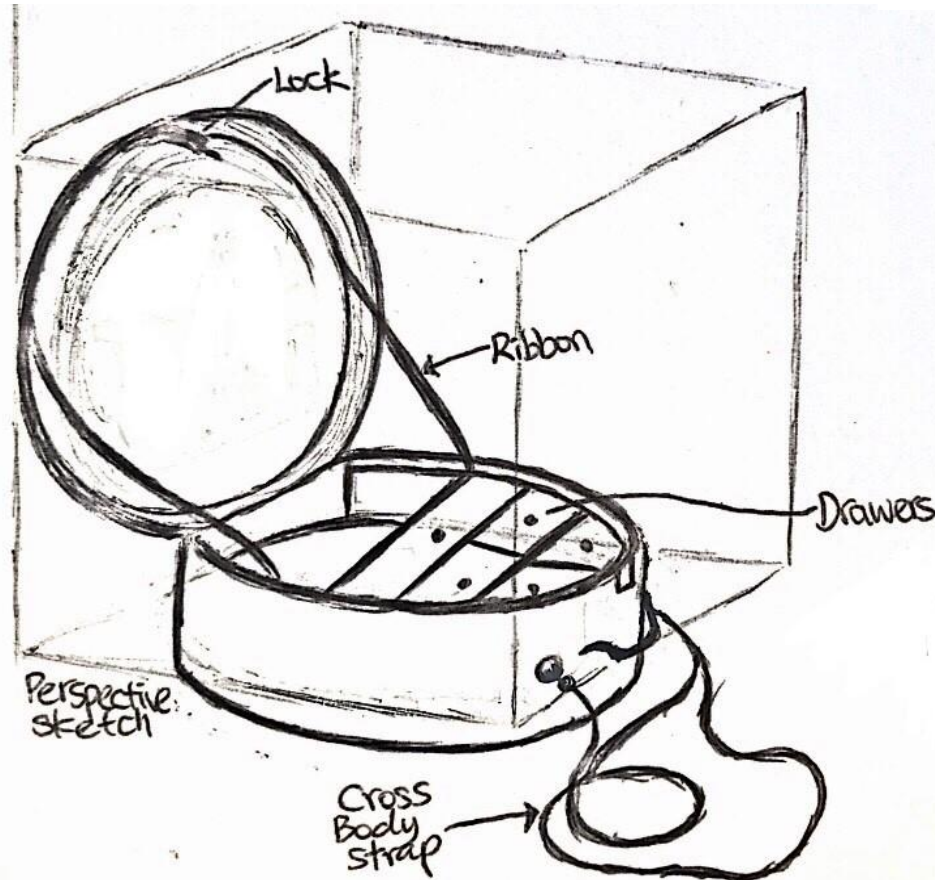

Design 3: Inspired by a slice of "Kiwi"



This "Kiwi" shaped design looks cool, and the sloping shape on the surface looks interesting. But I have realised that this design has a curved surface on the bottom, and it will be impossible to make it stand on the table, or any other flat surfaces. The reason is that the curved surface on the design will make it wobble around. Therefore, I decided to make some developments on this design.

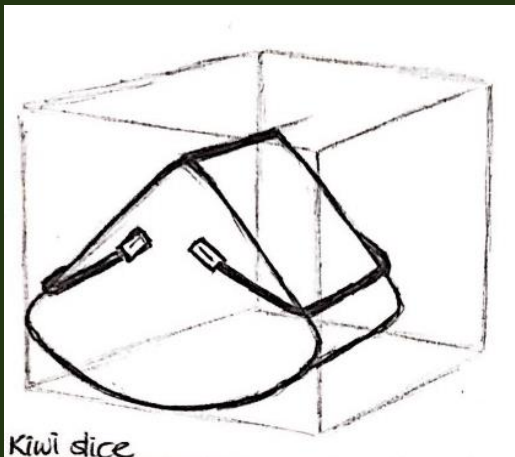

Kiwi slice

Roughly, the interior of the product has been designed, such as how it's going to be organised. However, giving some critical thinking, I realised it will be difficult to store stuffs in this organiser, and there may only be tiny amounts of spaces. Even though, the shaping of the design looks interesting, the most important part is the function, which is the storage spaces, which is why I do not really like it.

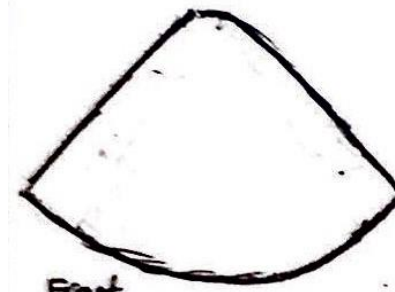

Front Elevation sketch

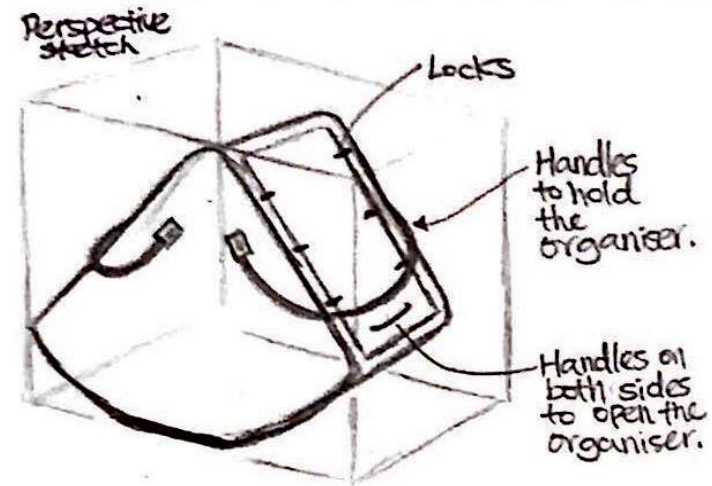

Perspective sketch

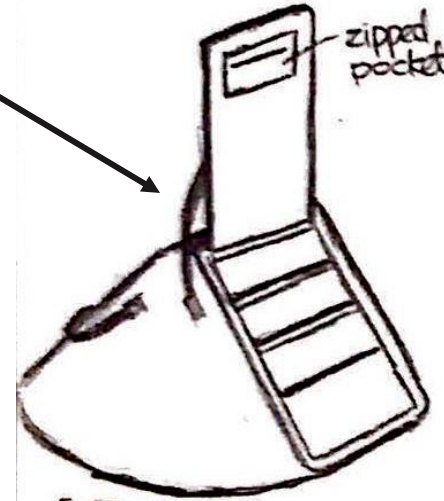

Respective sketch

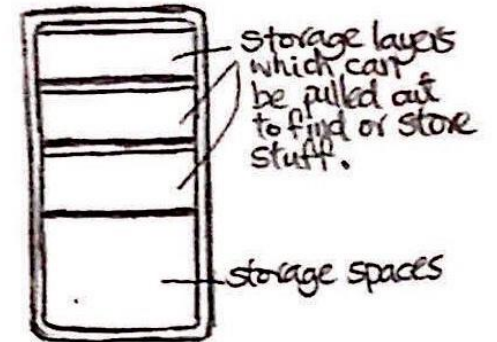

Elevation sketch (side)

I have made some developments to my original designs. I have redesigned the bottom curved surface of the product, by creating a thick flat line on the centre of the bottom's curved surface. So that the product can stand on any surfaces, without wobbling around, and this also prevents the chance of changing the original shape of the design.

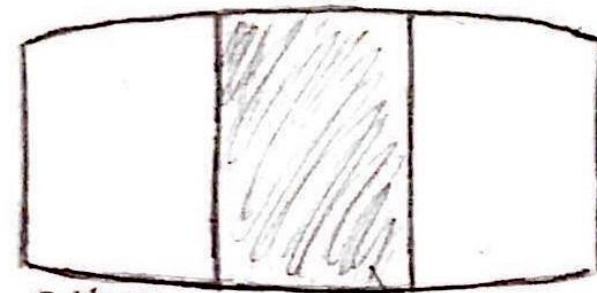

Bottom view sketch

Flat bottom, so that it can stand.

Design 4: Inspired by a slice of "Kiwi"

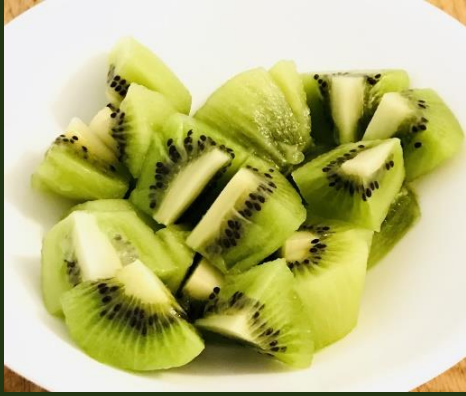

Furthermore, I have created another idea inspired by the shape of a slice of "Kiwi".

The design on the right is designed in the shape of a slice of "Kiwi", but I have explored by designing in a different way, by adding some shapes. For example, I have added legs for the design to make it stand up, and I have also designed some beautiful patterns on the top of the body shape. I have decided to design the opening part of the organiser in the front, and it looks like a cupboard, with two doors that can open. There are two handles attached to both sides of the product, so that it can be easier to carry when there is a high level of weight.

Overall, I like the way this is designed. This design has lots of different shapes and patterns linked together, such as curved patterns, curved edges, beautiful patterns, and some diagonal lines. The combinations of different elements make the design looks very nice.

These beautiful patterns are designed on the outside, around the top of the product and there are spaces created for the users to store more things. This means people can store things inside the beautiful patterns too.

This is a lock, which is used to lock up the organiser. For example, when the users are carrying the organiser, they need to lock it up, to secure the organiser from opening.

There are layers of storage organiser, which can be pulled out. Inside each layers, the spaces are organised for the users to store things and find things easily.

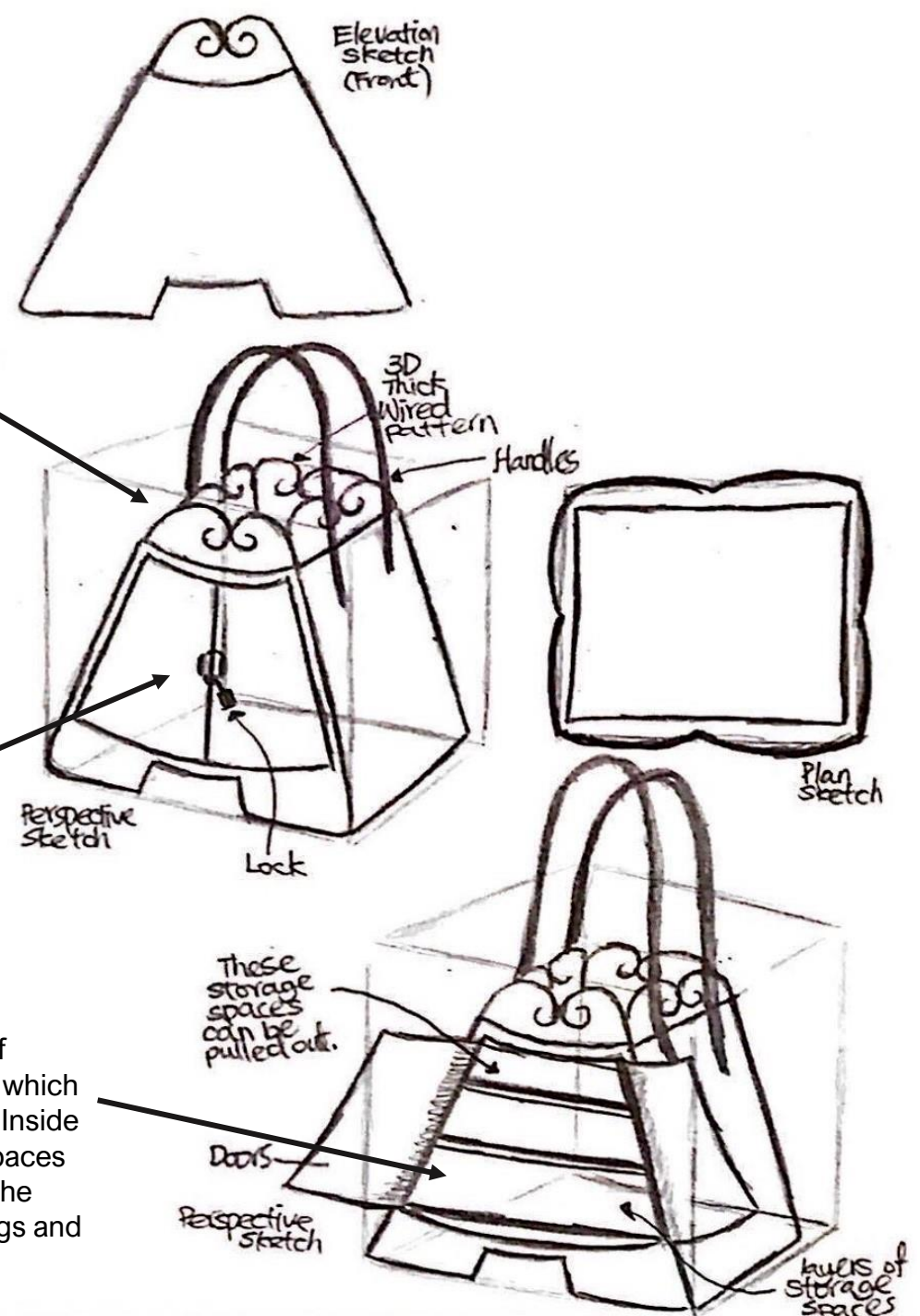

Design 5: Inspired by a slice of "Lemon"

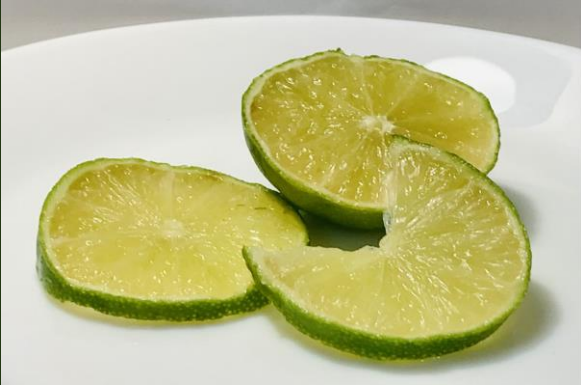

I have decided to redevelop the "lemon slice" design into something that looks fresh, and natural.

I like the shape of the "lemon slice" design, which looks interesting. But I do not like the design of a thin cuboid underneath the curved "lemon" shape, which does not match the design, and does not look blend in. Therefore, I am going to redevelop the shape of the design to make it look better and more natural.

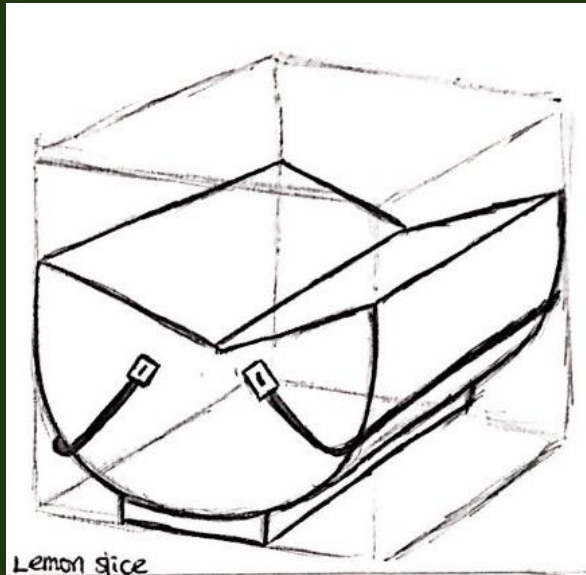

The design on the right has many curved designs, which makes me think of plants growing out from their stems, and while the plants are growing, some of them are growing in curved directions, and some are growing in another way. For example, trees grow in different directions.

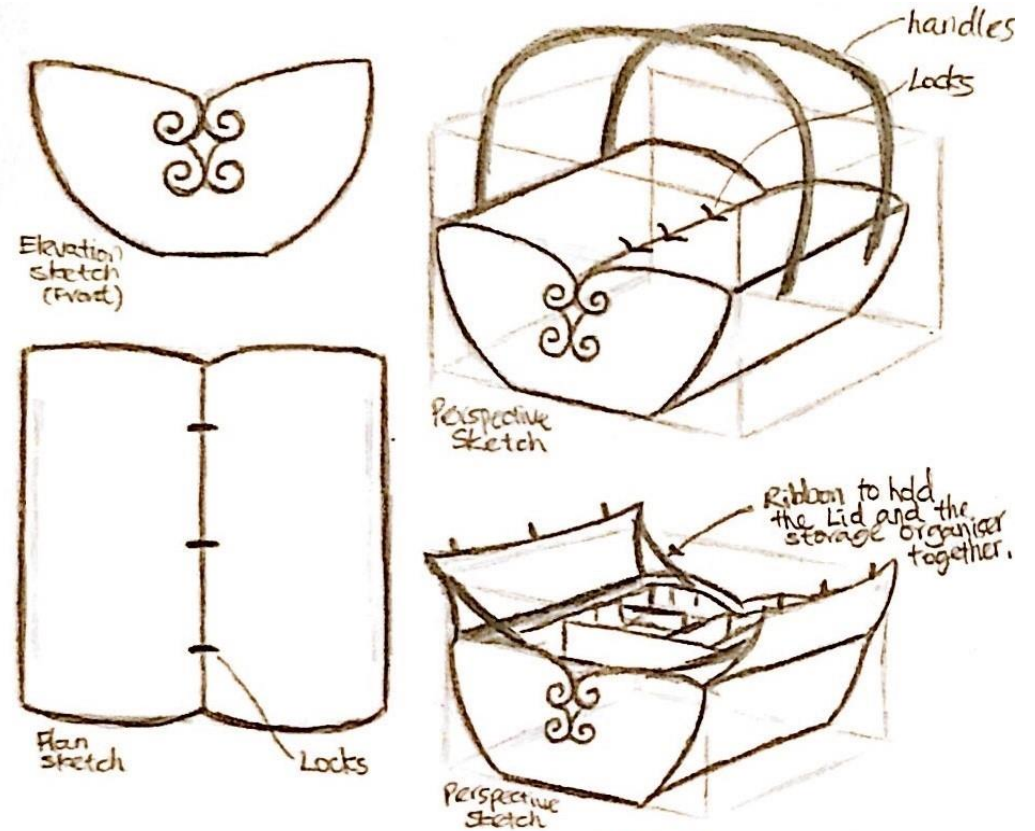

I have developed the opening lids into a curved shape, so that they look nice, and more things can be stored in them. The closed curved lids design makes me think of an unopened "lemon's flower petals", and when the user opens the lids, it makes me think of the "lemon's flower petals" opening, which looks fascinating.

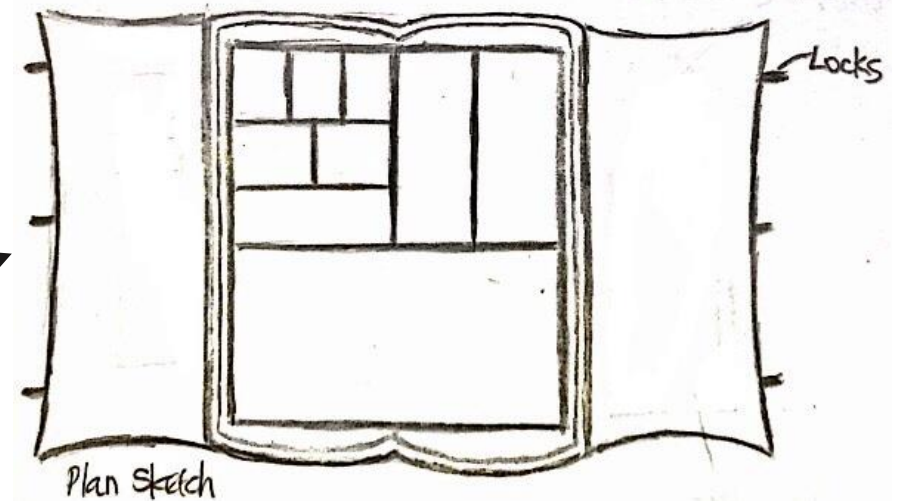

Design 6: Inspired by a slice of "Lemon"

Moreover, I have done another exploration, which is another idea inspired by the shape of a slice of "lemon".

The design on the right has been designed with many geometric shapes, and straight patterns, which looks great. The part that I like the most in this design is that rather than keeping the original "lemon slice" shape, I have changed the shape of some angles to make them look better. For example, there are some sloping shapes in the design.

I have also decided to design the opening of the product in another way. Therefore, I have designed three drawers (front view), which the users can pull out to find stuff. And there are two more openings (lids) designed on the top (plan view), which the users can open to store stuff. I have designed the end of the handles in curved shape, which looks like the shape of the branches and look natural.



Overall, I like both Design 5 & 6, which are inspired by the "lemon slice". The reason is that both of them have special and natural features.

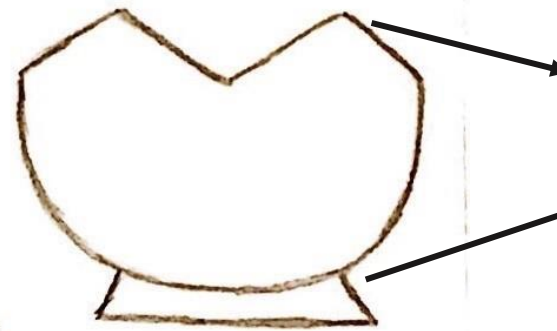
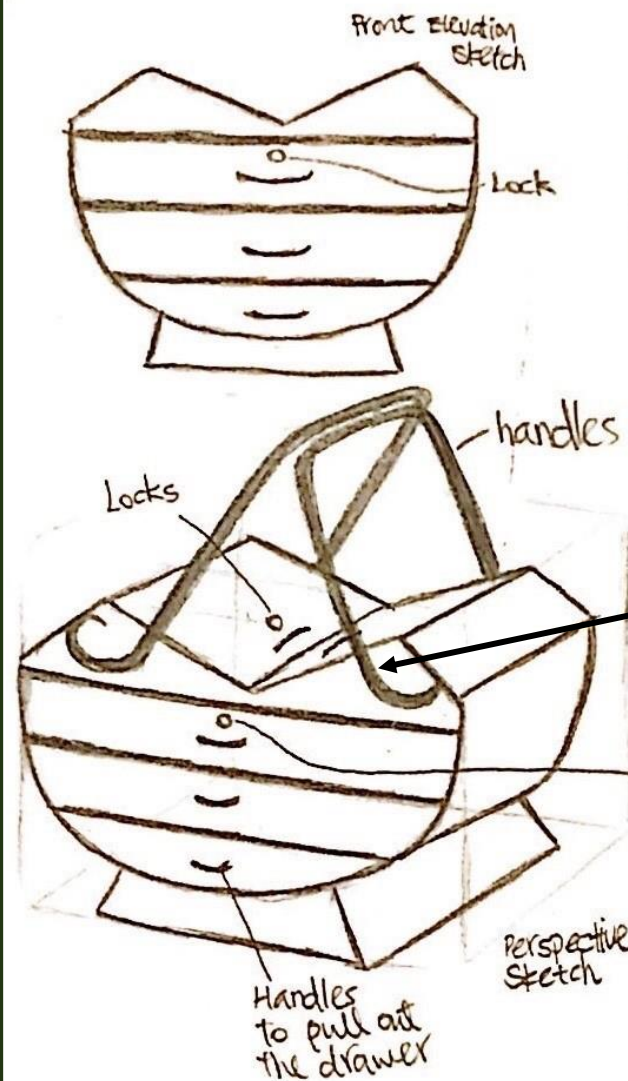

The shapes of these angles have been redeveloped into a style, where there are more geometric shapes blend into the design, which makes it look interesting with a change of style.

These handles have curved ends, which look like the shape of a tree's branches.

Locks to lock the drawers.

Perspective sketch

Interior view of the locks
Interior view of the handles being attached to the product.

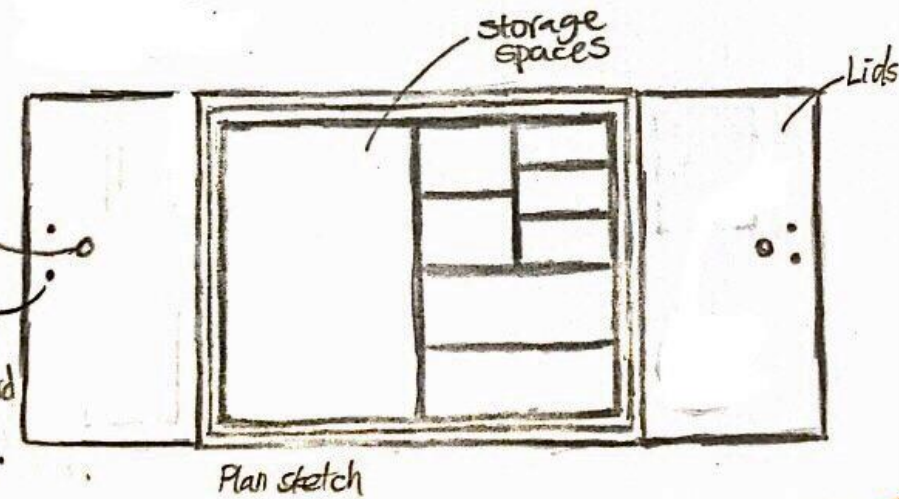

Plan sketch

Design 7: Inspired by a Strawberry



I really like the strawberry shape, which looks beautiful and elegant. However, the bottom part of the design is not flat, so it cannot stand. So I need to redesign it to make it stand up. Also, the way that the handles are designed on both sides of the strawberry shape looks a bit simple and do not blend in well with the strawberry shape to make the design stand out. Therefore, I am going to make some adjustment to lighten up the design.

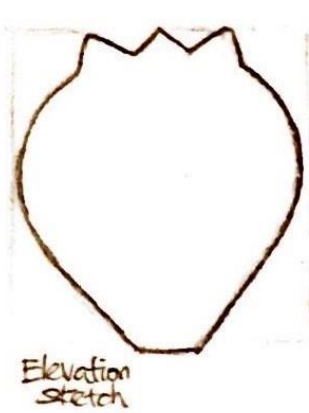
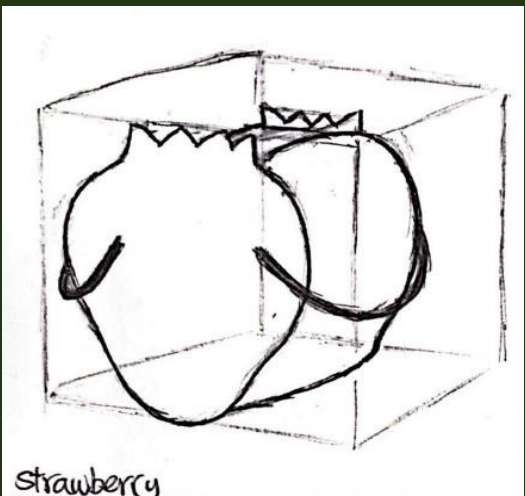

I have redeveloped the bottom of the design by making it flat so it can stand up.

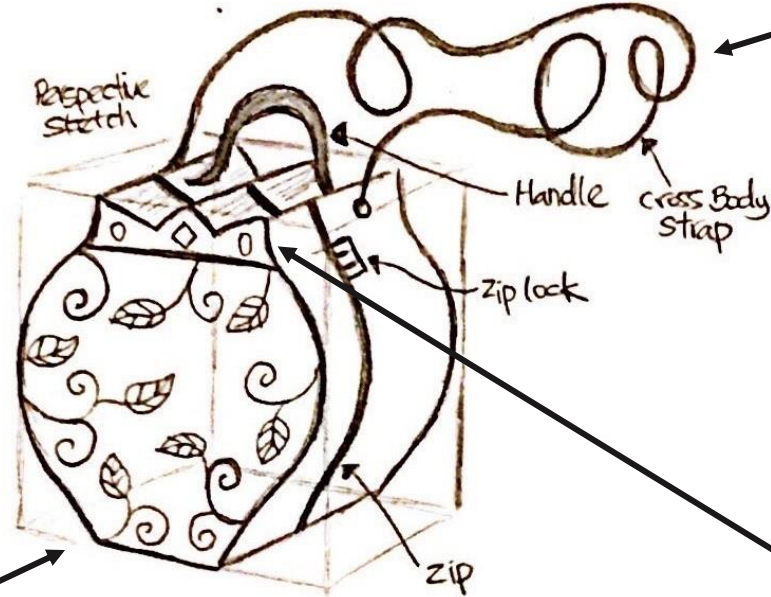

There are also some more changes that I have made, for example, the location of the handle, and I have also designed a cross-body strap on both sides near the handles. This means that the person can carry the organiser in two different ways.

The crown pattern is designed on the strawberry's calyx, which looks beautiful, and I really like the design.

Another development that I have made is how the organiser opens. In order for the organiser to open, the users have to lay it flat on a table, with the strawberry shape facing up. And the locks are designed by both sides of the organiser.

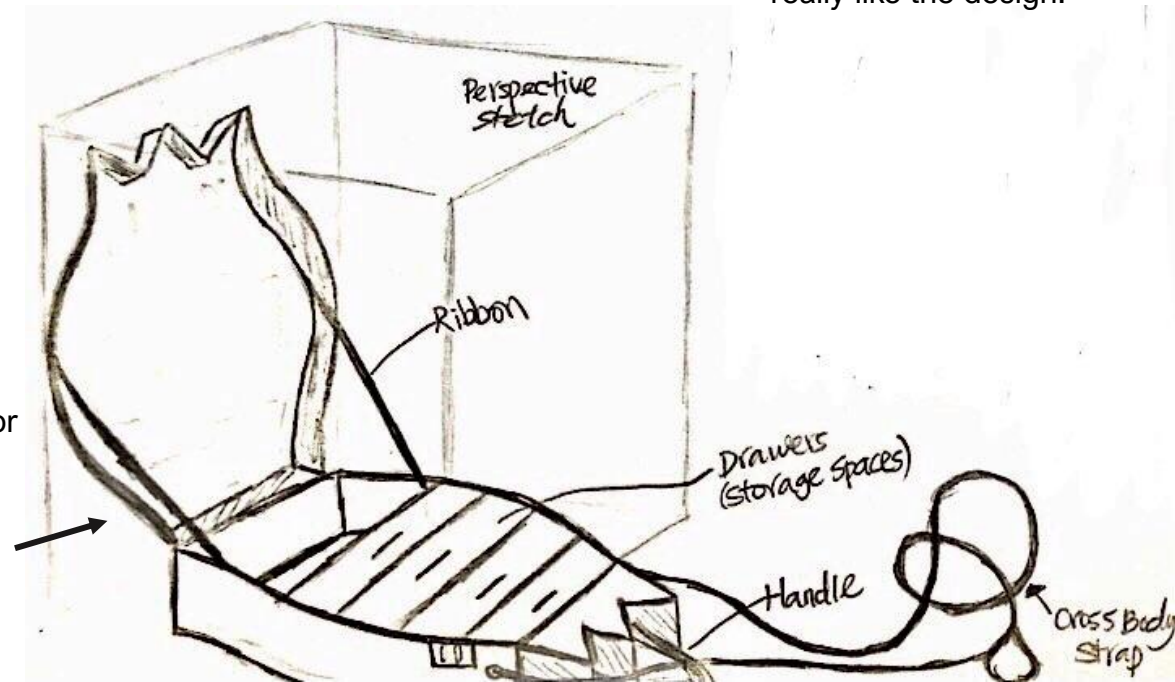

Design 8: Inspired by a Strawberry



In addition, I have also explored designing another organiser inspired by a “Strawberry”.

Design 8 looks a bit like the other design on the previous page (Design 7). The difference is that this design is created in a geometric shape, with many angles. While, in the other design (Design 7), there are more curved parts mixed with a bit of angular shapes, which make the design look a bit different and creates a different style. When I looked at Design 8, I have always been thinking about an inspiration from a pineapple rather than a strawberry, as the shape of the development, and the pattern on the design do look like a pineapple.

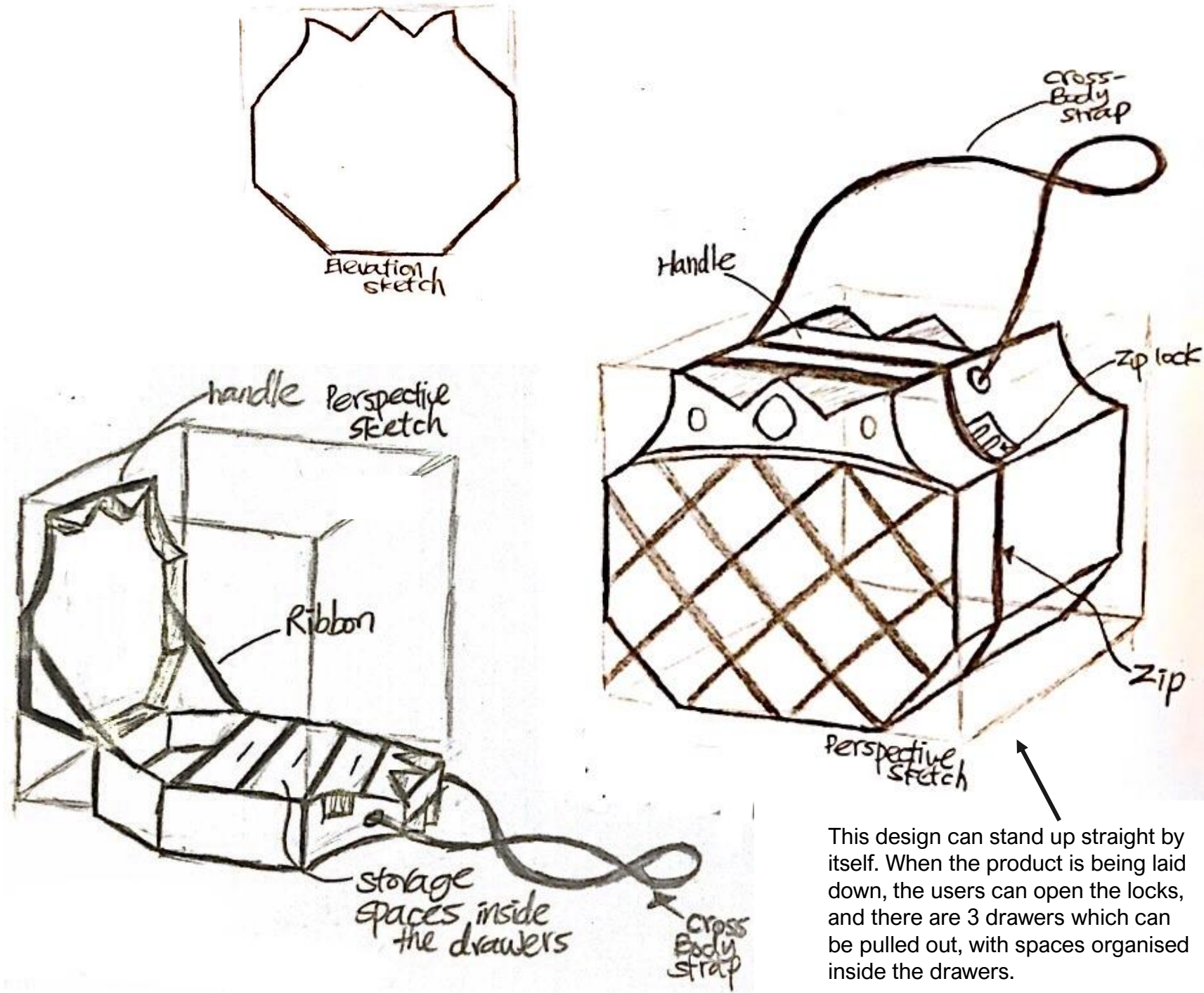

This design can stand up straight by itself. When the product is being laid down, the users can open the locks, and there are 3 drawers which can be pulled out, with spaces organised inside the drawers.

Design 9: Inspired by a Leaf

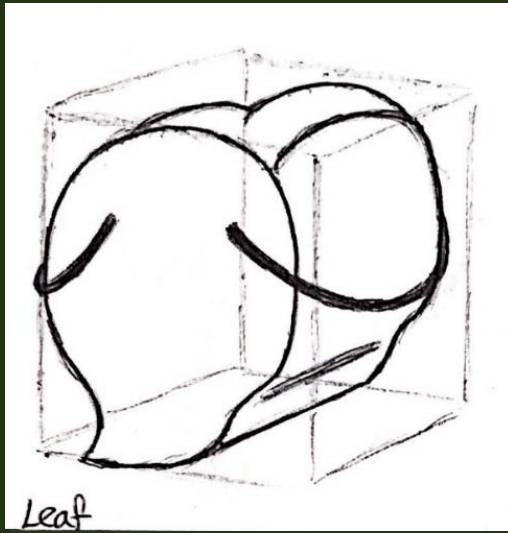

The design of the leaf shape looks nice and natural. However, I do not like the way that the organiser is designed and the position of the feature, for example, I do not like the location of the handle, and the leaf's position, which do not blend. Therefore, I have decided not to change the leaf's shape but reposition the handles and the leaf's shape.

I have tried to reposition the leaf design at different angles, and I found a great position for the leaf design, which is in a horizontal position.



After I have found the position that I like, I have started to do some thinking about the way in which the product should open. I have decided the product is best to be opened with the leaf design facing down onto the table.

The natural shaped design of the organiser looks nice, and the combination of curly patterns (inspired by the leaf's vein) on the surface have lighten the design. Also, the position of the features look better with the handle being structured on top of the organiser and a crossbody strap to be attached on the sides of the organiser. This give the users more choices on the way that they want to carry the product.

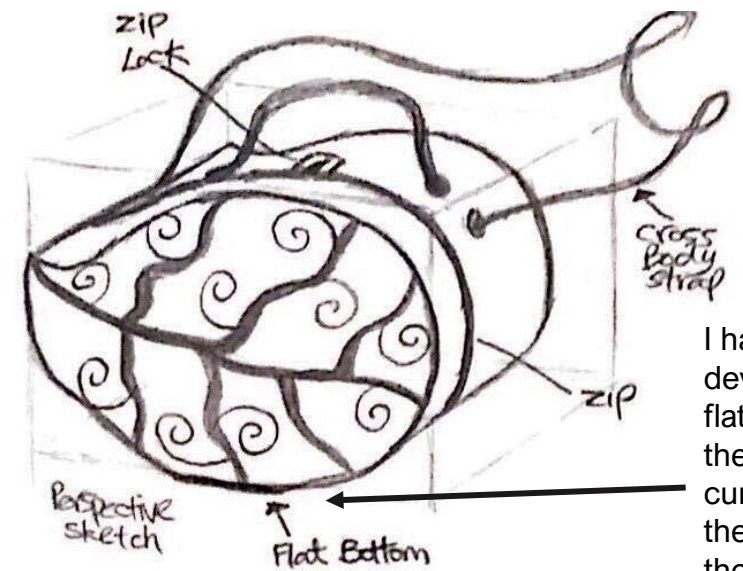

I have also developed a thin flat surface on the bottom of the curved part of the leaf, so that the product can stand up by itself.

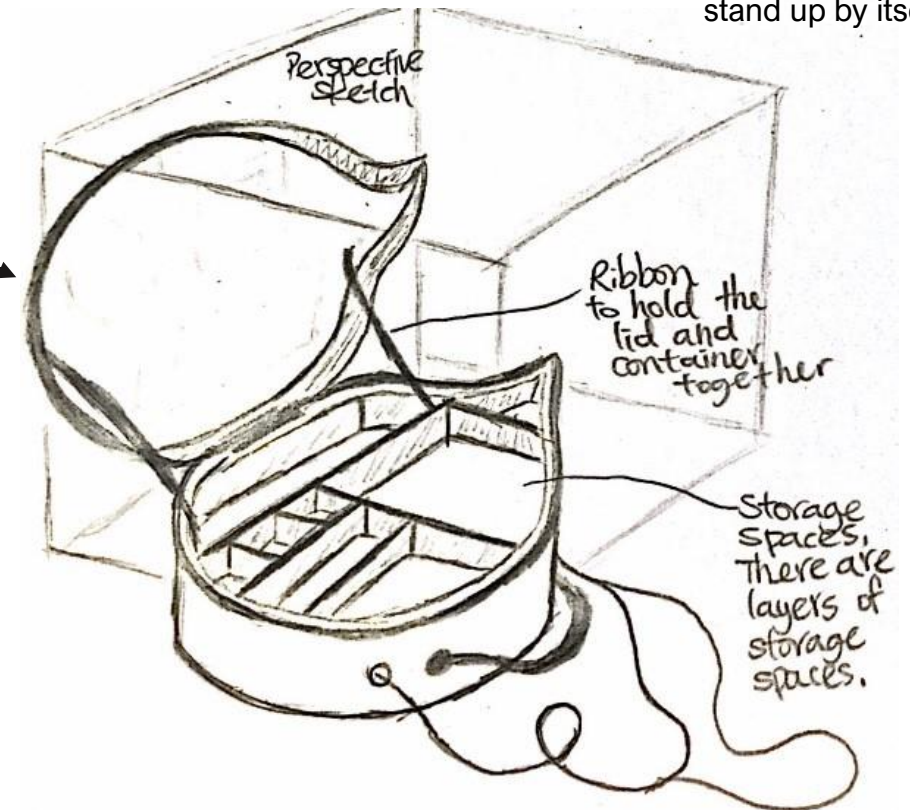

Design 10: Inspired by a Leaf

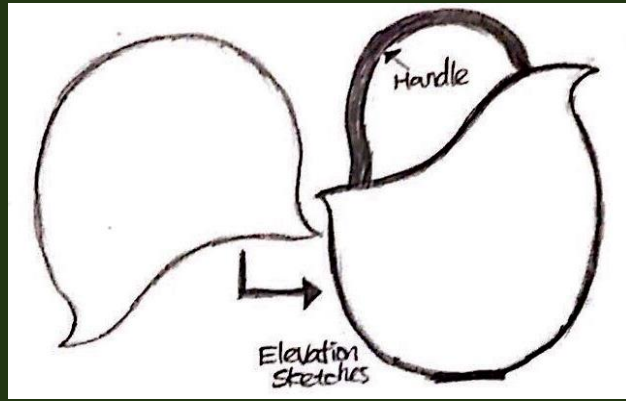

Here, I have designed another storage organiser inspired by the shape of two leaves overlapping each other with a bit of changes on the shape to make the shape more curved. Later on, I developed the shape inspired by the leaves into a storage organiser with some wavy and flowy patterns and shapes, which looks natural and can spread the sense of nature.

In the design, I have also added some features to make the design portable for users to use, which shows my consideration towards them. For example, I have designed a crossbody strap to be attached on the sides of the organiser. Then, I have kept the original position for the handle's design, as the position looks nice and blend in with the shape of the design. This means that the users can have the choice of either carrying the organiser using the handle or crossbody strap.

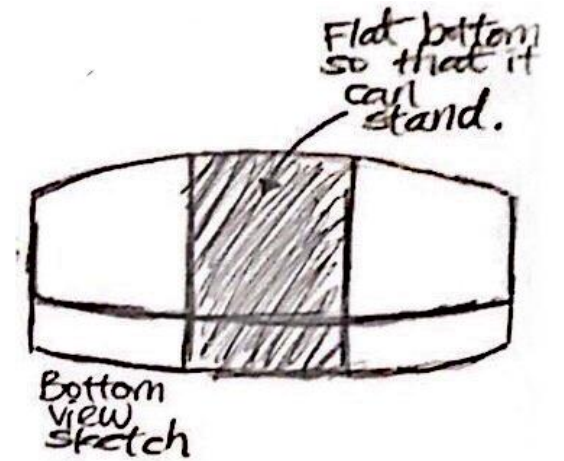
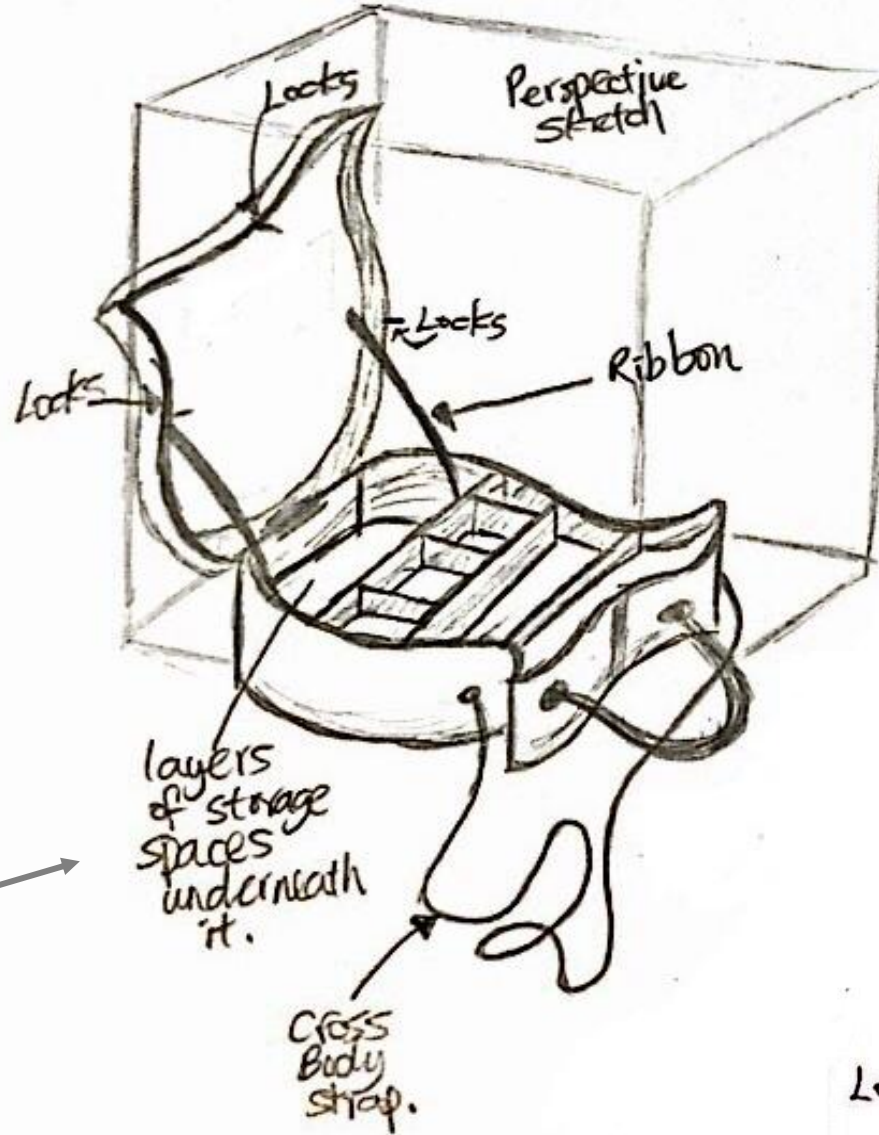

After all the modelling experiences, I have also developed the curved base into a section of flat surface, so that the product can stand up by itself. When the users want to open the organiser, they can lay it down.

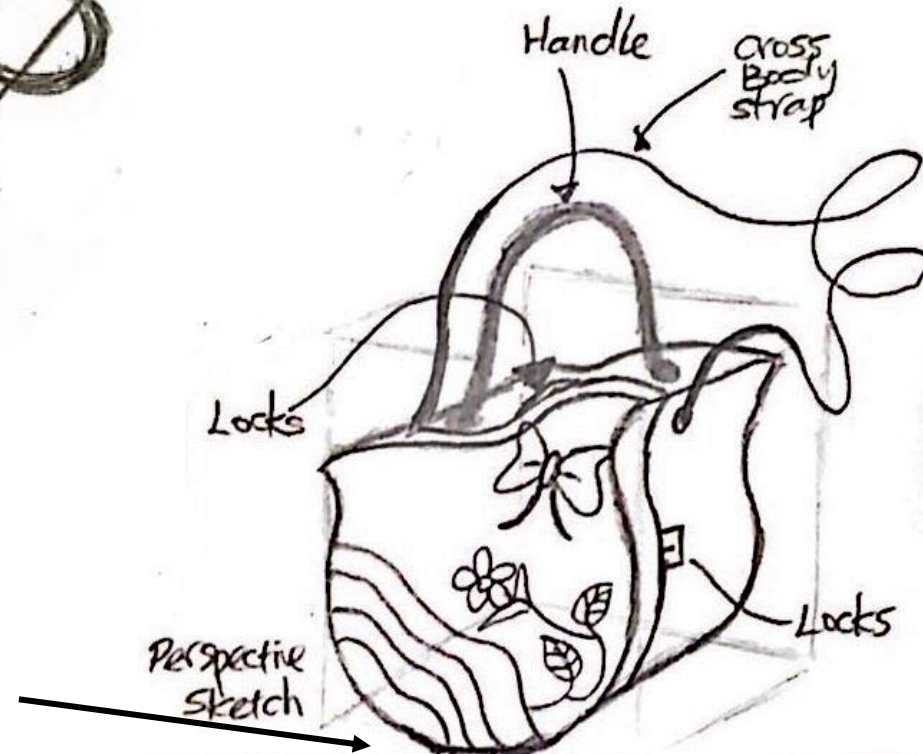

Design 11: Inspired by "Flower Petals"

This is the design of three of the flower's petals. I find this design a bit too detailed, and some of the shapes in it are hard to make, and it will also be hard for the users to use and store stuffs. Therefore, I do not like these flower petals' design.

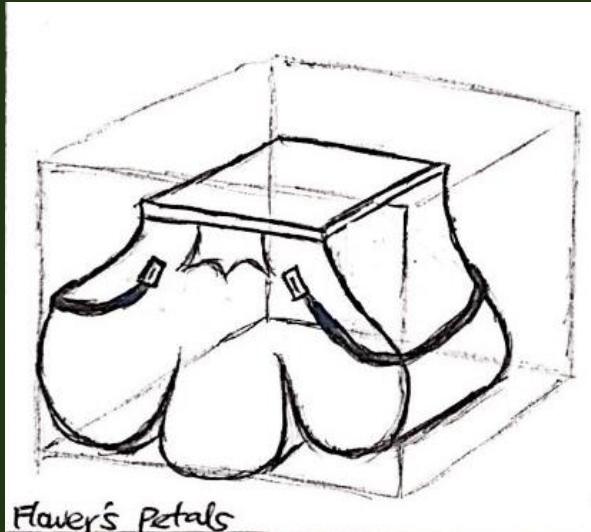

In order for the product to be useful, and look nice, I have decided that I'm going to redesign the "Flower petals" design. I have found another flower that I like, with beautiful petals, and my idea is inspired by it.

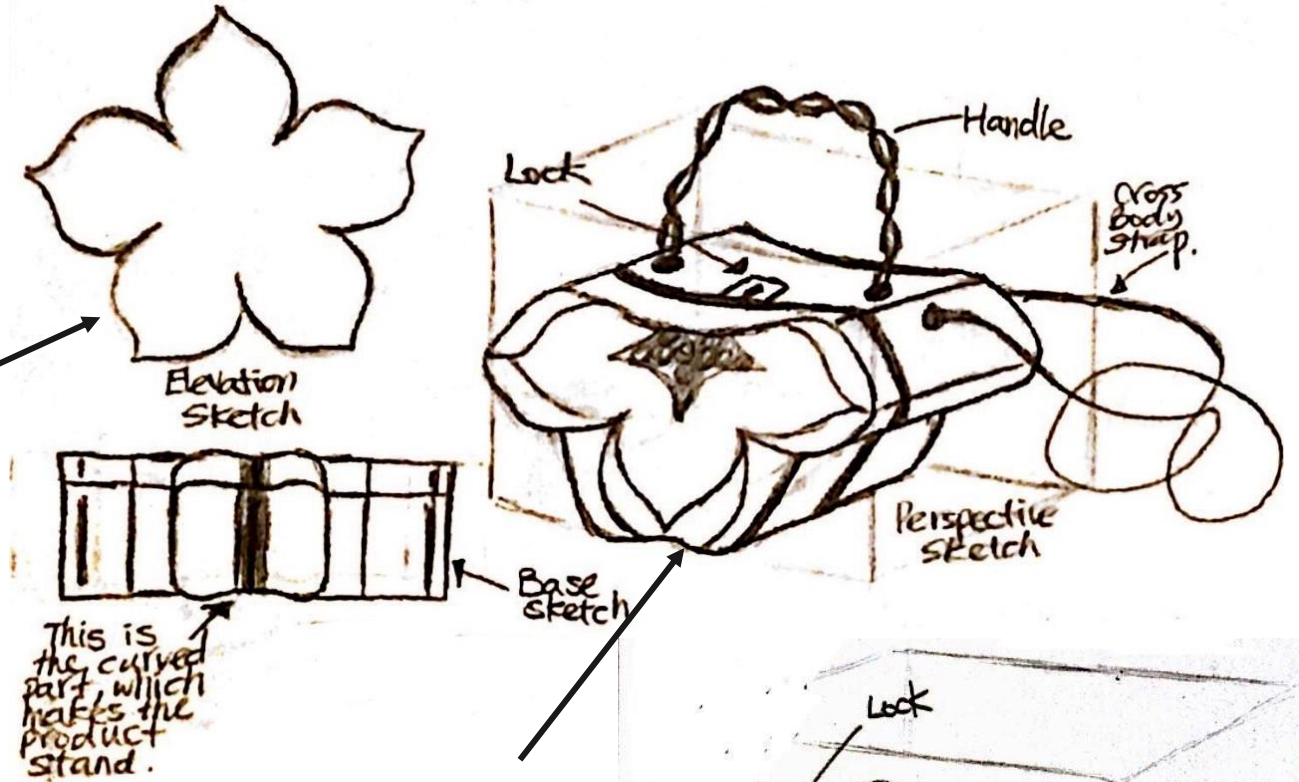

After all the modelling experience previously, I have used an idea that I have learnt in this design. The idea is that in order for the product to stand up, I have designed a big wavy shape at the bottom of the design, that looks like the "W" shape.

I have also used three flower petals in this development design, and I added some features to make the product more stable and secure to store stuffs. For example, the handle is designed on the top of the organiser and the crossbody strap is attached by the side of the organiser,

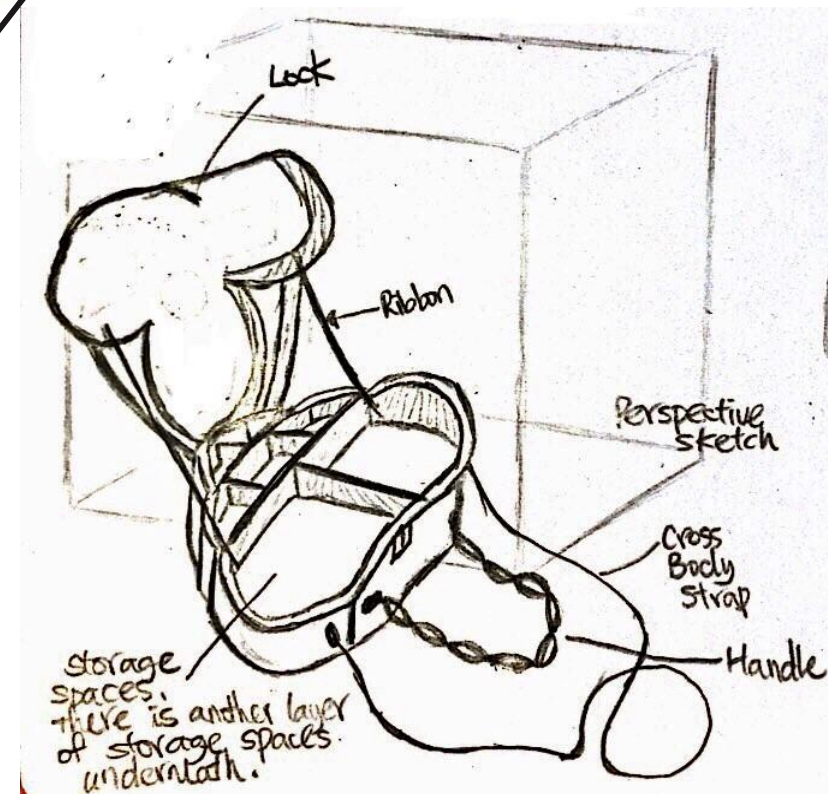

Design 12: Inspired by "Flower Petals"

The design on the right is also inspired by the shape of the "Flower petals". I have tried out ways to explore the shape of the "Flower petals".

The design on the right has been designed in the shape of a single flower petal. The curved and wavy shape of the flower petal's design looks lovely. I have changed some bits of the flower petal, for example, I have turned the sharp angles into curved angles, this prevents people from getting hurt. Another development is that I have turned the curved bottom into a wavy shape, that looks like a "W's" shape. This enable the product to stand up by itself, and also looks nice with the flower petal's design, rather than flat bottom surface. In the design, I have only added features, which include having a handle attached on both side of the organiser at the top, so that this makes it easier for the users to carry when they have heavy things in the organiser.

I think this design looks pretty, and I like the design of the flower petal's shape.

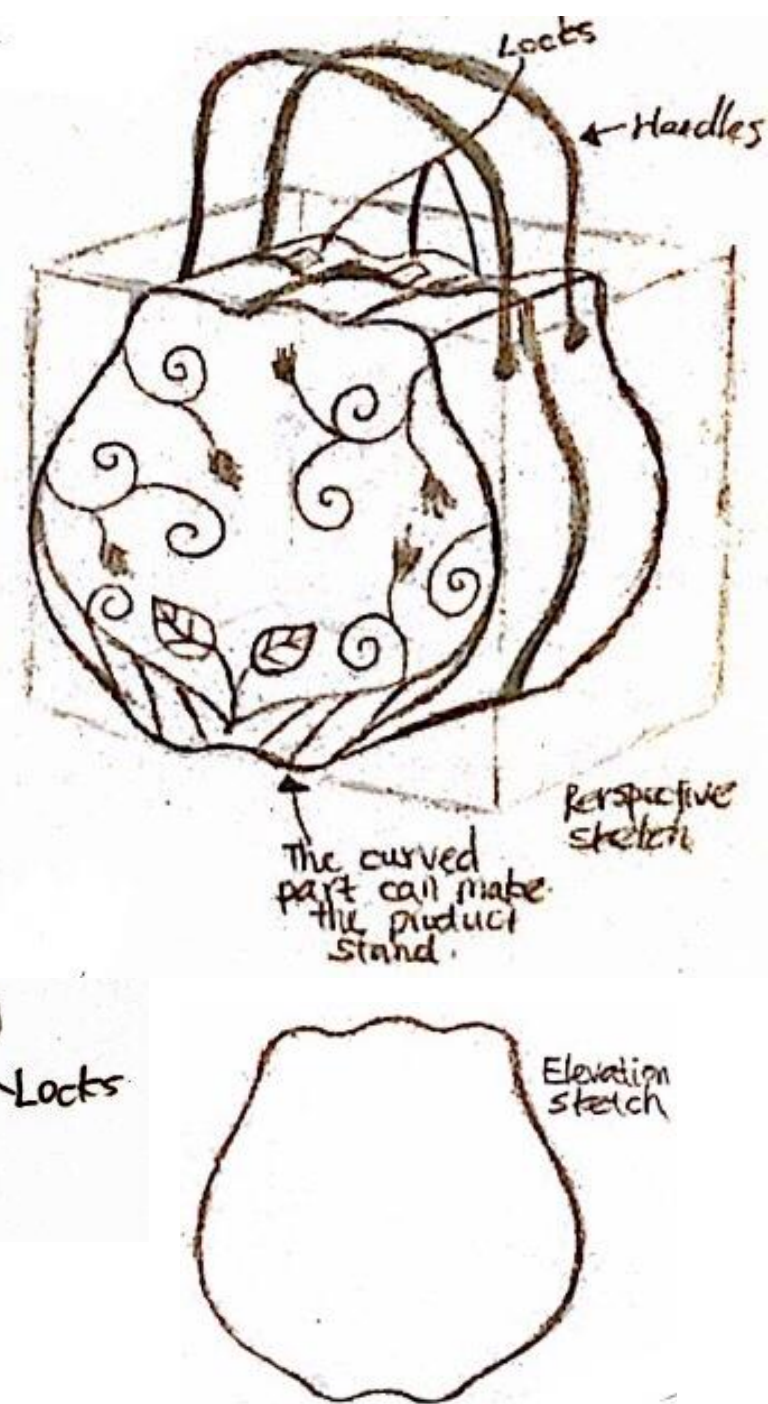
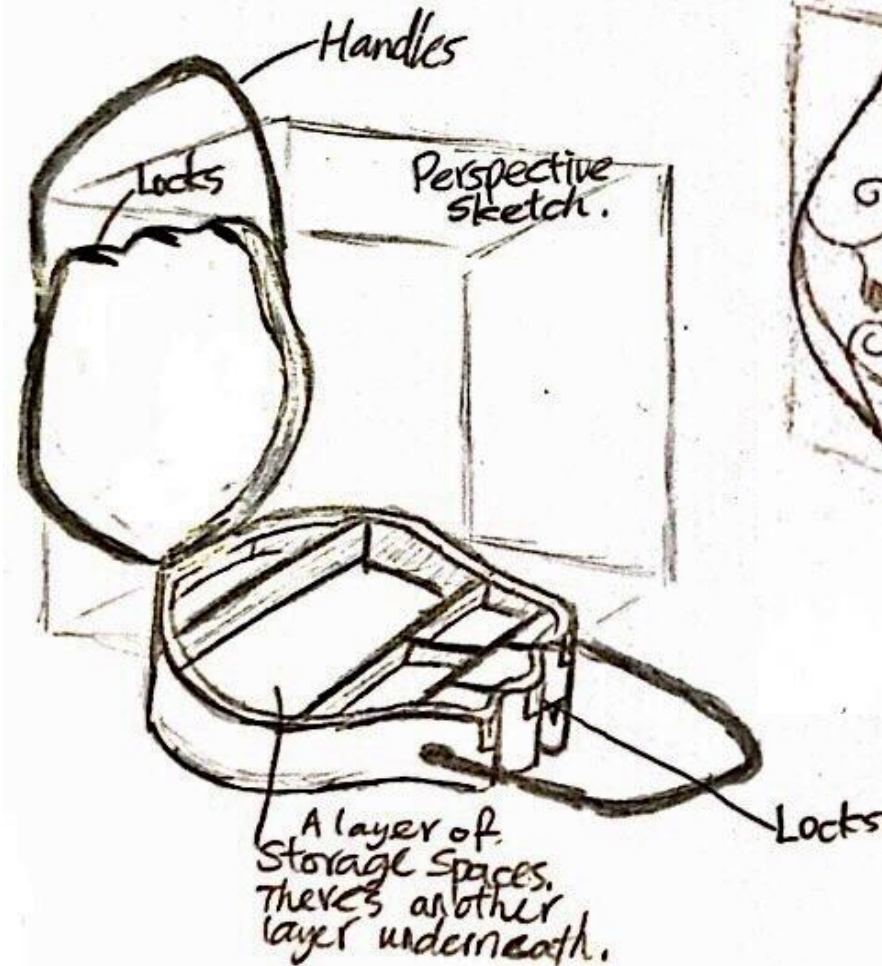

Models of My Design Developments

(Natural & Organic)

Model 1: Inspired by a "Strawberry"

In this model, I have used different kinds of materials, which are cardboard, golden wire (handle), and red ribbon (cross-body strap). I have made this model to see how the design look in 3D and if I need to make any improvements. For example, making this model have made me realised that when the organiser is closed and stand up, then the things in it will fall apart and make the interior space messed up. Therefore, I need to design a protection layer to prevent things from falling when the organiser is opened or closed.

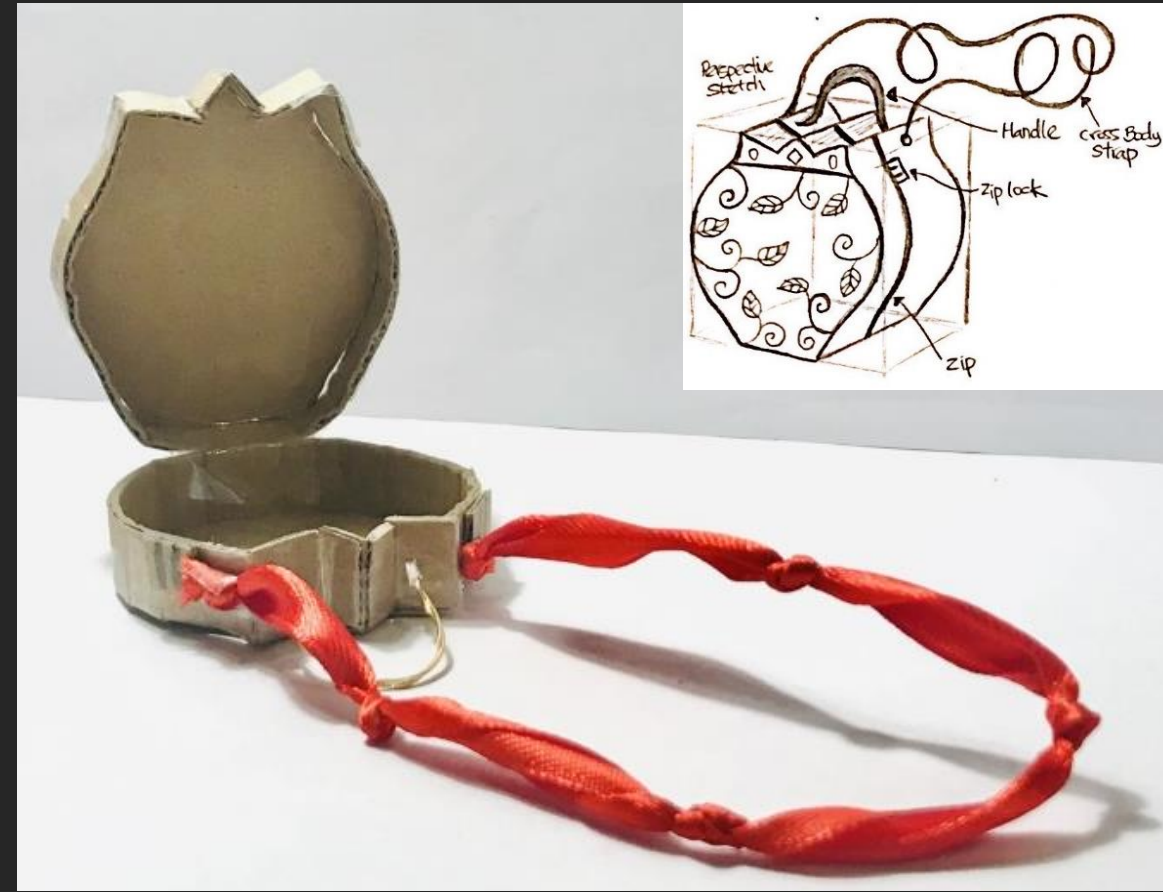
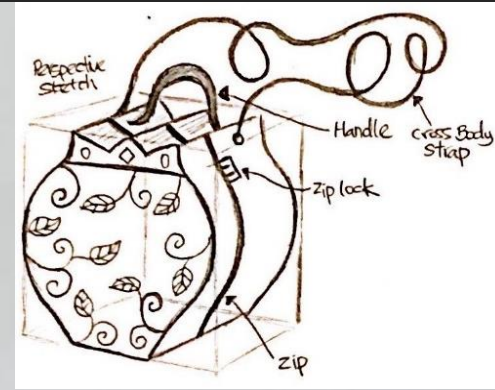

The opened version of the storage organiser.



The closed version of the storage organiser.



Model 2: Inspired by a slice of "Kiwi"

This model is made of lots of different materials, which are white foamboard, white card, black card, black foamboard, golden wires (handles), and pink wires (Wired patterns have created a space on the top of the product in the centre, where things can be stored into the space.). Making this model have let me realised that this design looks nice and pretty, however, it looks difficult to carry it with some small parts, and the handles look a bit too weak to carry heavy things. Therefore, I need to consider about the function of the storage organiser more carefully, so that the user can carry the portable organiser easily without worrying about the design.

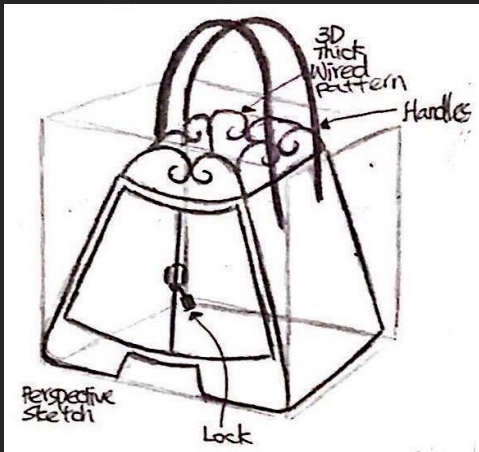

A storage space in the centre.

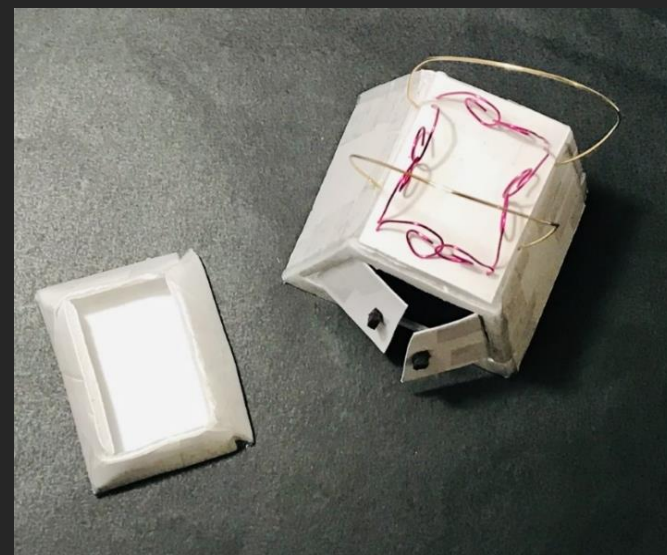

Secondary Research: Slotting Techniques



The verb "slot" means fitting something together using slots (noun), which are long narrow openings. Therefore, the "slotting technique" is a way of fitting or putting things together using long narrow openings, without any materials (e.g., glue or tape).

Slotting techniques can be used in making sculptures or models without any glue. In order to make a 3D model, you only need to cut out geometric shapes with slots included on the shapes, and after that, you can fit those shapes together to turn them into a 3D model.

There are different kinds of slotting techniques, which look different, but they all fit the shapes together, and then turn them into 3D models.

Types of Slotting Techniques:

- Slot Joints
- Folded tab joints
- Flange tab joints
- Tab & Slot joints
- L-brace joints
- Mortise & Tenon Joints

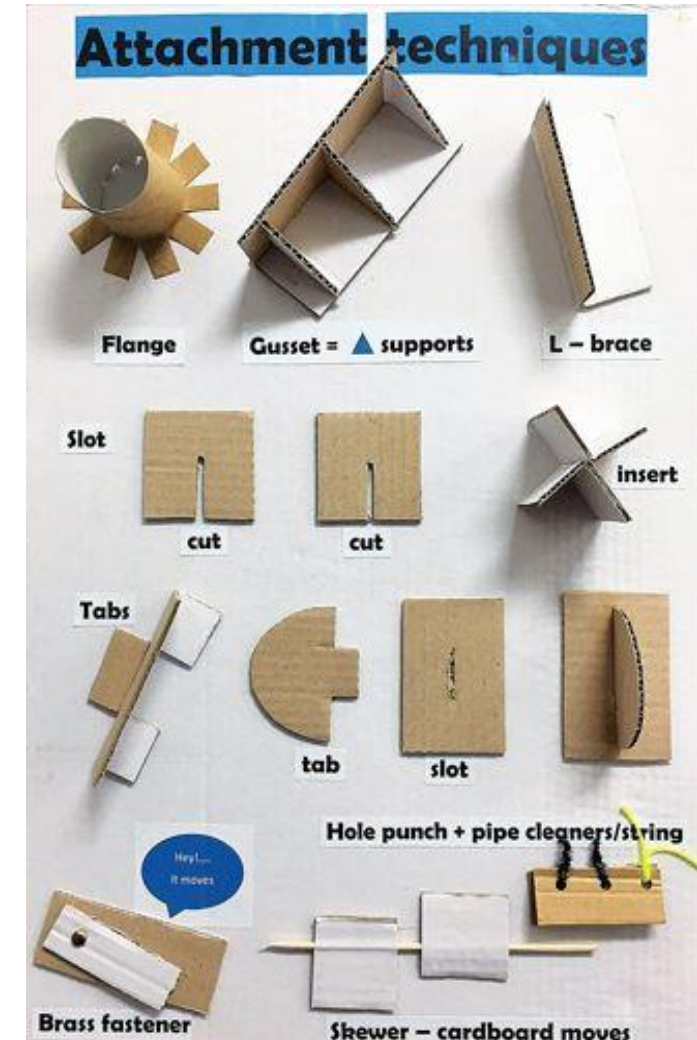
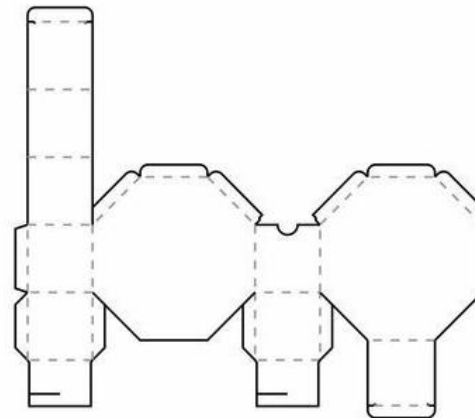
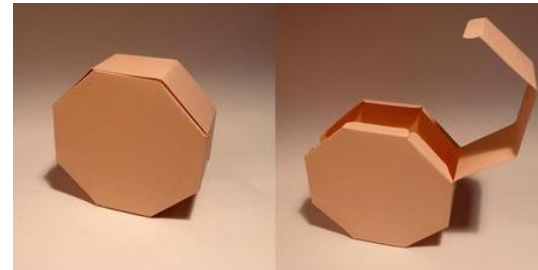

Secondary Research: Slotting Techniques

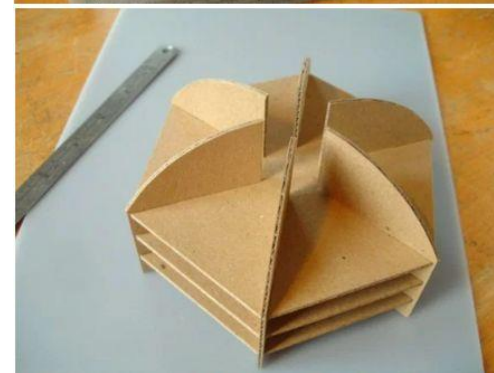
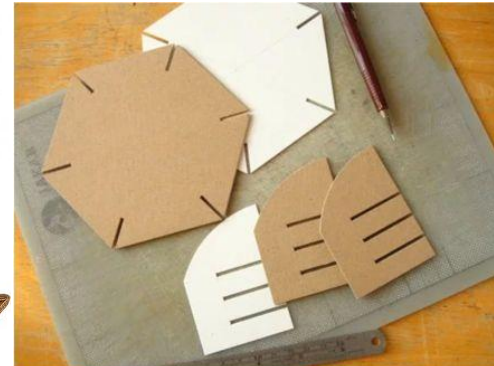
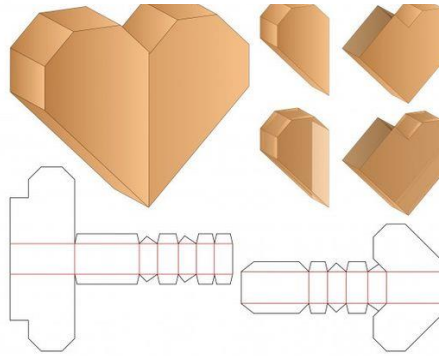
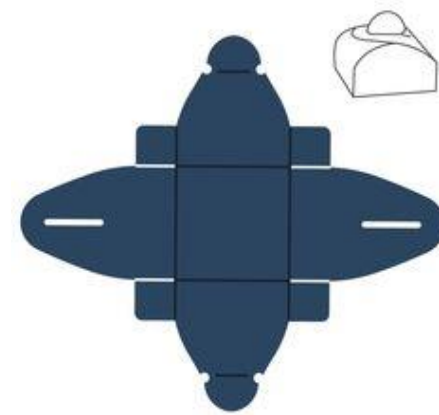
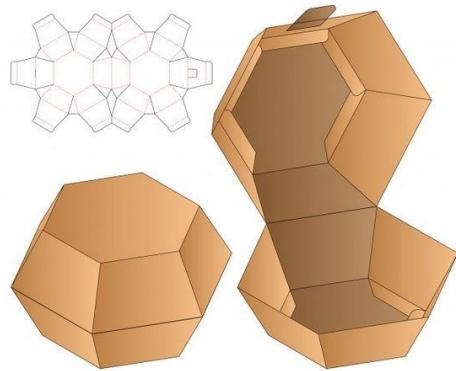
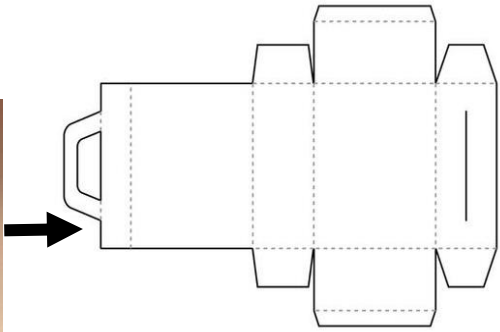

CARDBOARD ATTACHMENTS



FLANGE

L-BRACE



SLOT



CUT



CUT



INSERT

TABS



TAB

SLOT



SLOT



BRASS FASTENERS



HEY-IT MOVES!



HOLE PUNCH + WIRE



FOOT

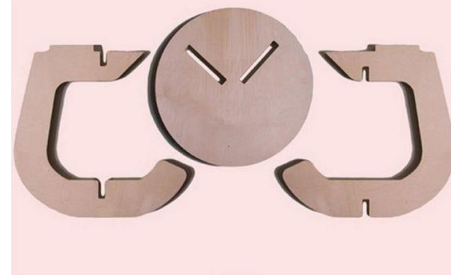

Record: Slotting Techniques, Design 1

Cardboard Insert Slot

I have made a simple cardboard slot to get a basic experience. This means that when I am building my own product, I get the idea on how to join my design's components together, using the slotting technique. Making this model has been easy, as I just needed to cut through a line on both pieces of cardboard, and then I can join them together, without the use of any glue or other supplies.

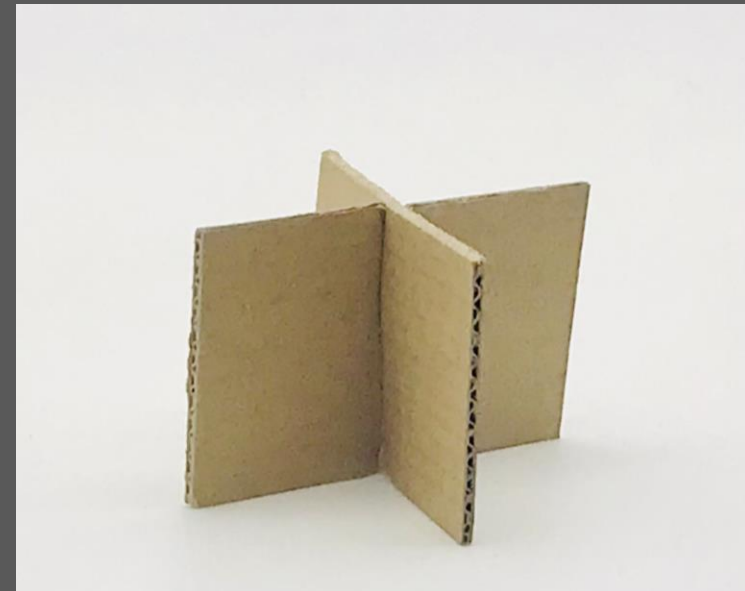
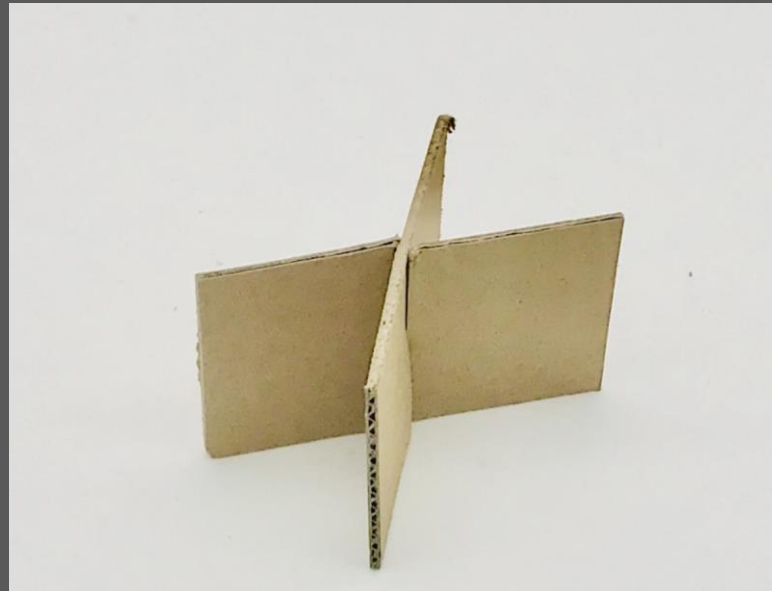
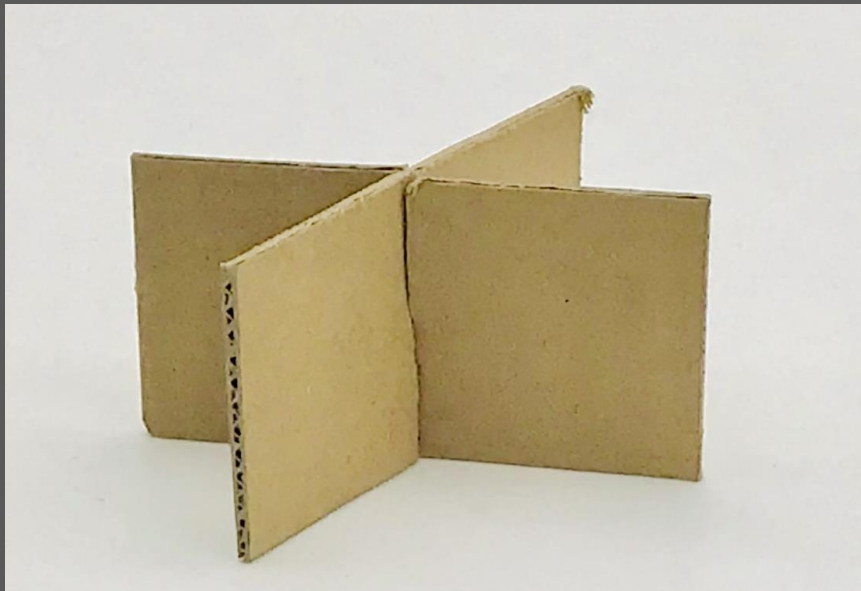
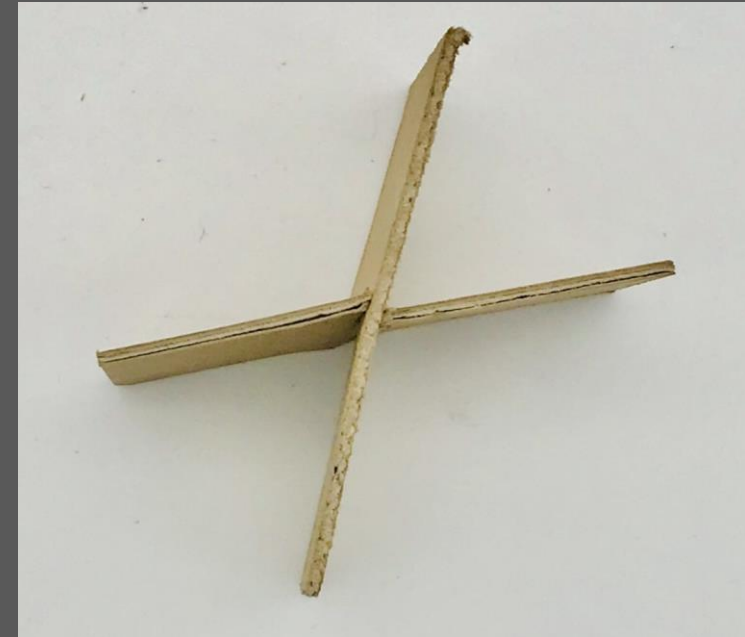
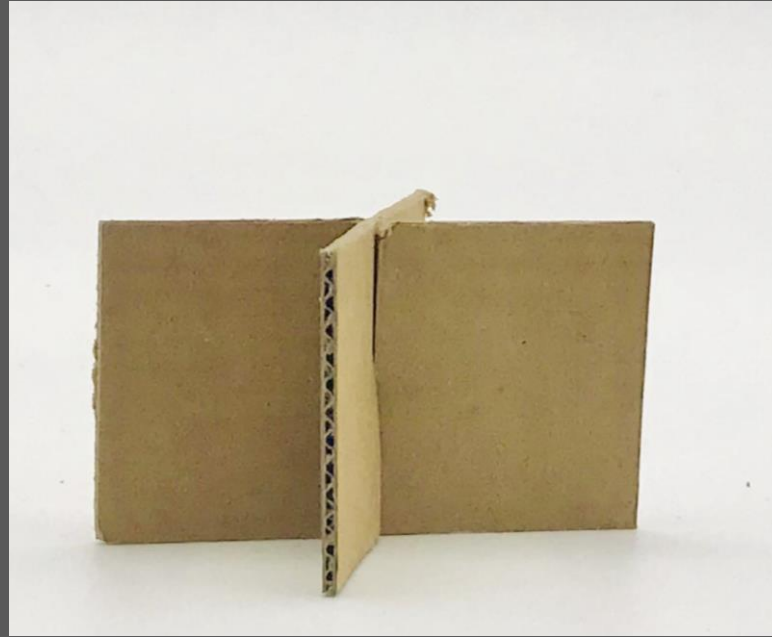

Record: Slotting Techniques, Design 2

Cardboard Insert Slot

I have made a sphere using the slotting technique. Firstly, I have cut out cardboard circles, then I have cut three slots onto each of the cardboard circles, and then I fit all the slots together to turn into a 3D sphere. Making this model let me understand that I do not even need to roll the cardboard around or use any glue to make a sphere shape, whereas I just need to cut cardboard circles, and using the slotting technique to fit them all together, that saves a lot of crafting materials (e.g., tapes and glues).

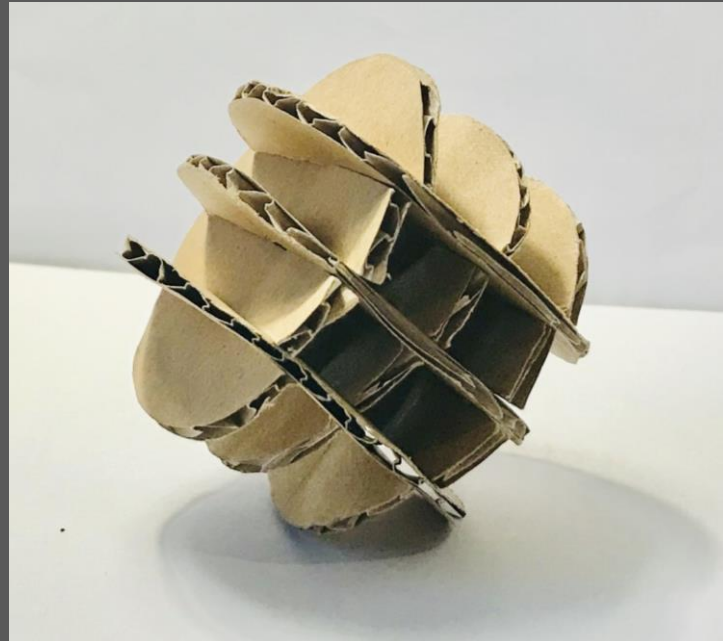

Record: Slotting Techniques, Design 3 Cardboard Insert Slot & Tab Slot

These are the templates that I have created using cardboard, and then I have combined them all together to create a 3D shape. I have made this model to give me an experience on the way to create different shapes using slotting technique. For example, the model that I have just created can be useful when making the interior layout of the portable storage organiser. The reason is that this model helps creating the space into sections.

Turn into a "storage organisation layout".

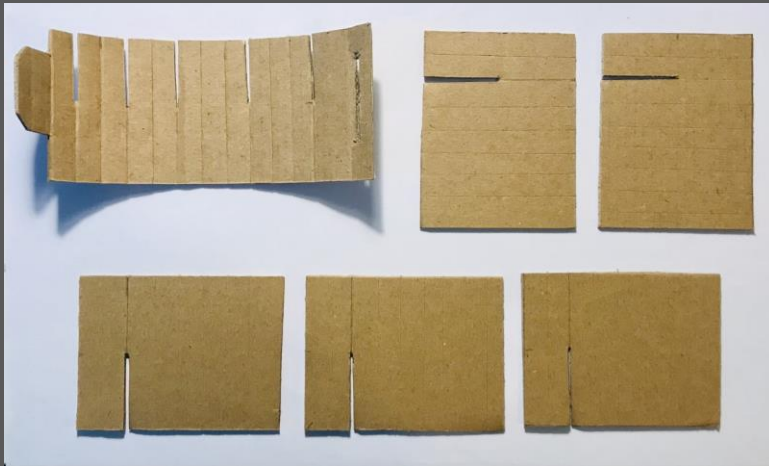

A cylinder shape that I have created, which acts as a centre structure to support the other curved structures.

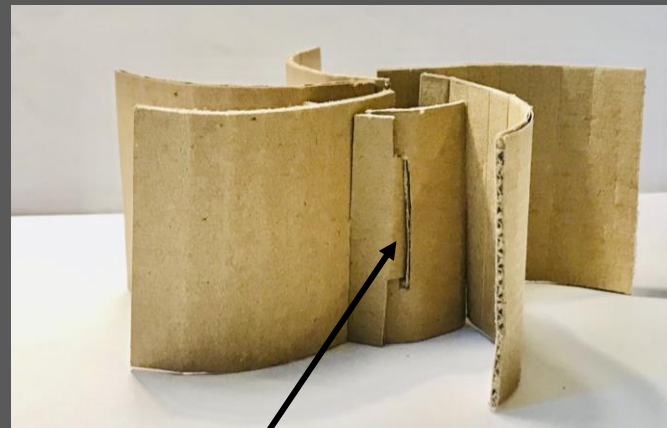

I have made a "Tab slot" to turn the flat cardboard into a cylinder shape.

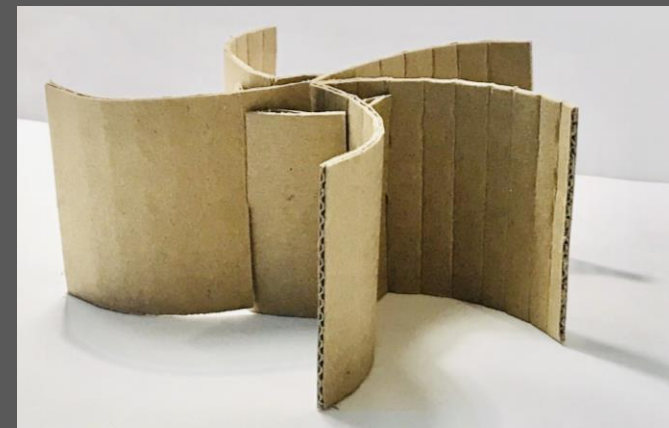

I have created a storage organisation layout using the slotting techniques that I have learnt. This design looks like a flower's shape, which is beautiful, and match the "organic theme".

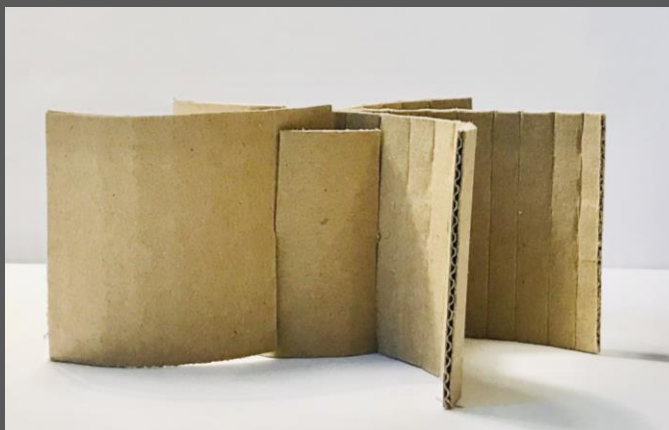

Record: Slotting Techniques, Design 4

White Foamboard Insert Slot & Mortise and Tenon Joints

I have made a random structure, that looks like a seat, or a table. This random structure has been made using the combination of two slotting techniques, which were a foamboard slot, and a mortise & tenon joints. Making this structure has given me a basic understanding on how to make the model of a product using the combination of different slotting techniques, and analyse what type of slotting techniques will work to build the structure.

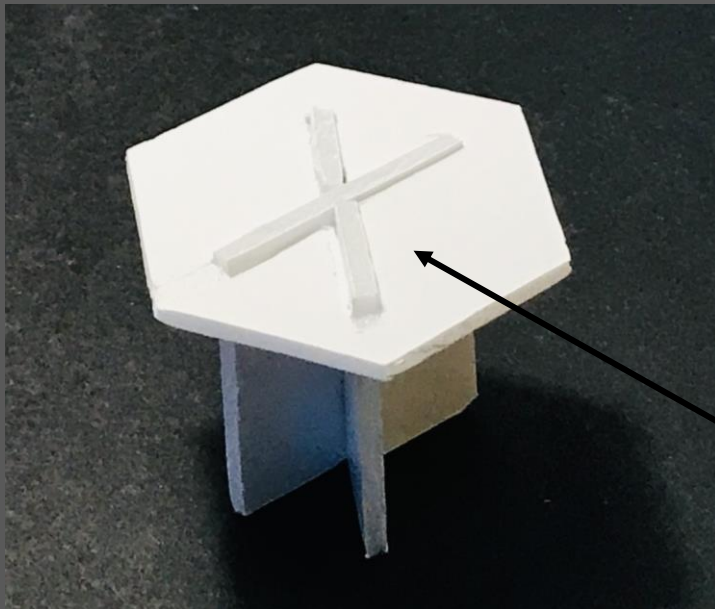
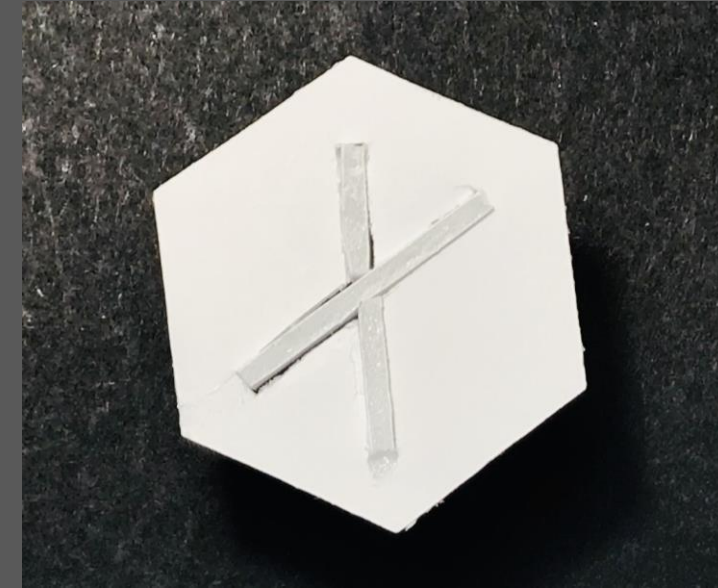
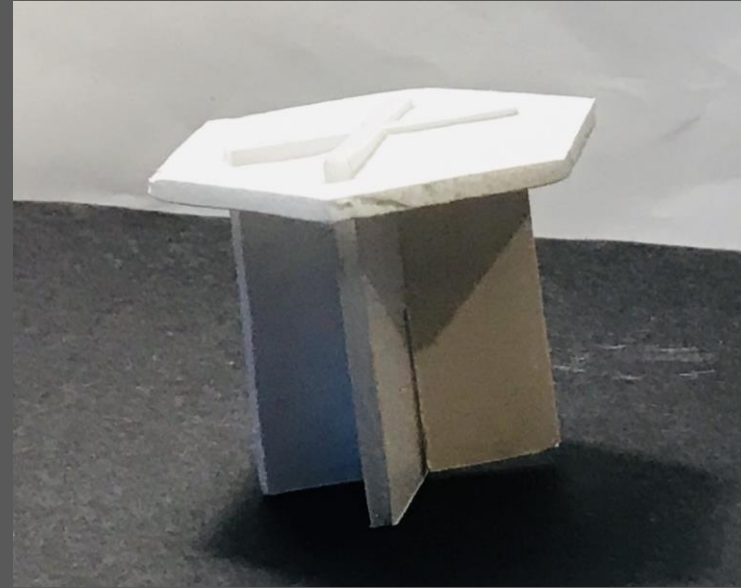

Foamboard Slot

Mortise & Tenon Joints

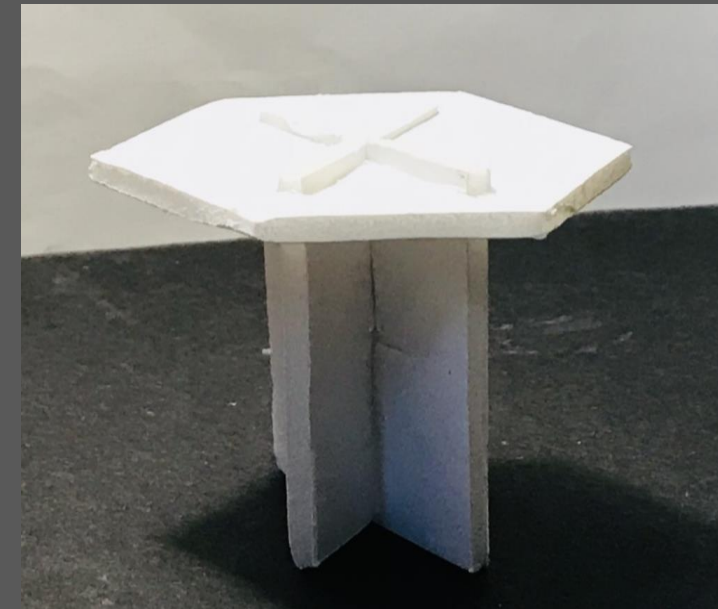
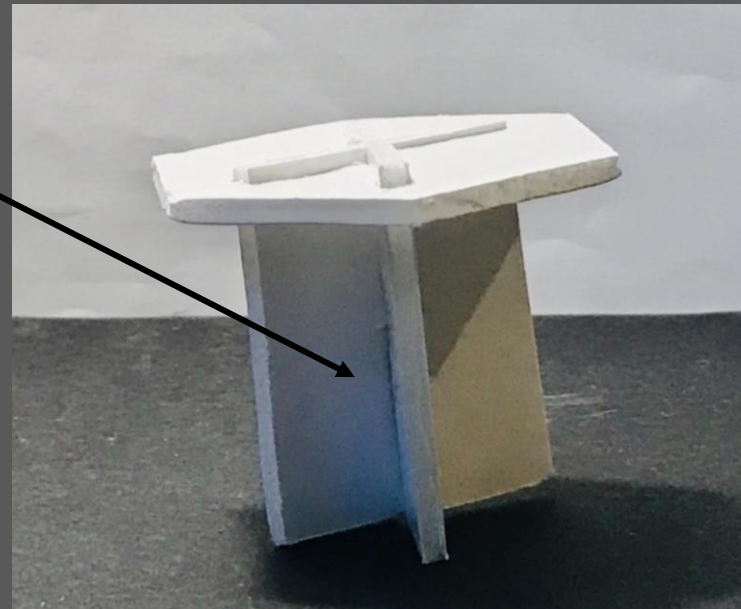



Secondary Research, Pinterest: Storage Layout Designs

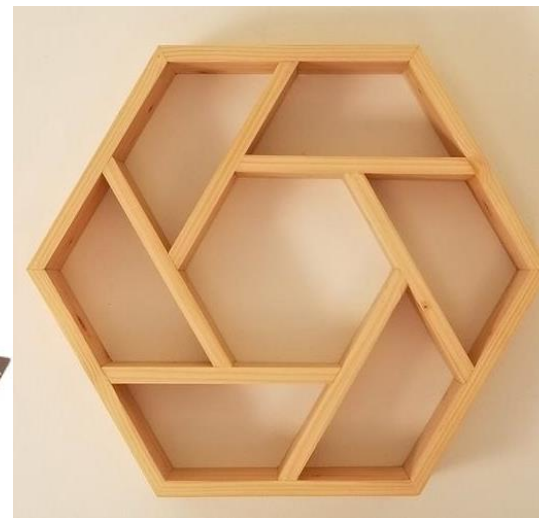



Secondary Research, Pinterest: Storage Layout Designs



Development: Designing the "Interior Layout" of the Portable Storage Organisers, Strawberry Inspiration

Design 1

I have designed the interior of the storage organiser in the style of swirling branches, which reflects the theme of "Natural & Organic". The branches separate out the interior space into sections, where art equipment can be stored in different sections. On the interior side of the lid, I have designed some small and big pockets, where tiny and medium things can be stored (e.g., paint brushes and scissors). I really like this interior design, as the interior branches layout matches the shape of the strawberry, which make both of them blend together in a natural way.

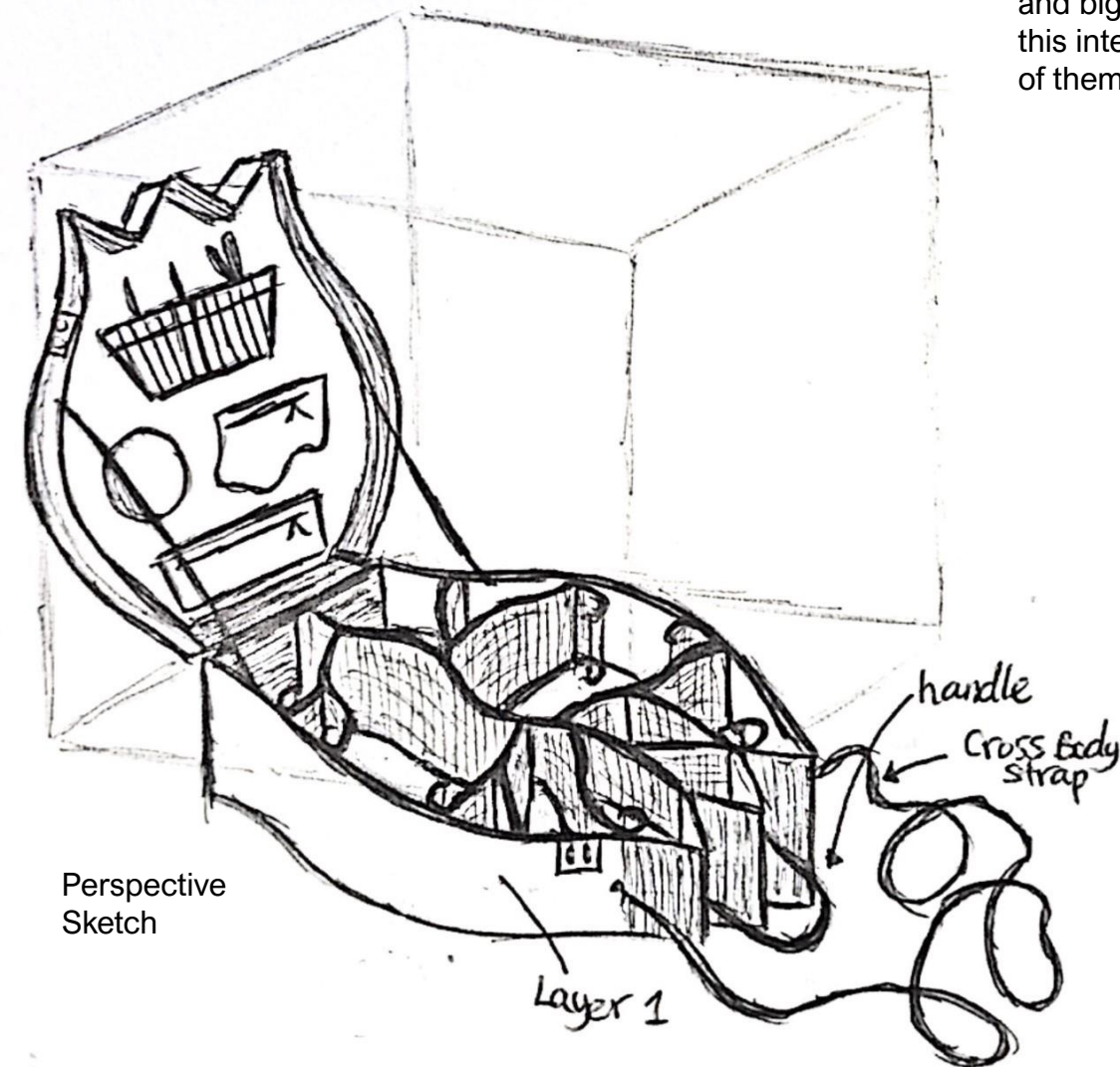

Plan sketches

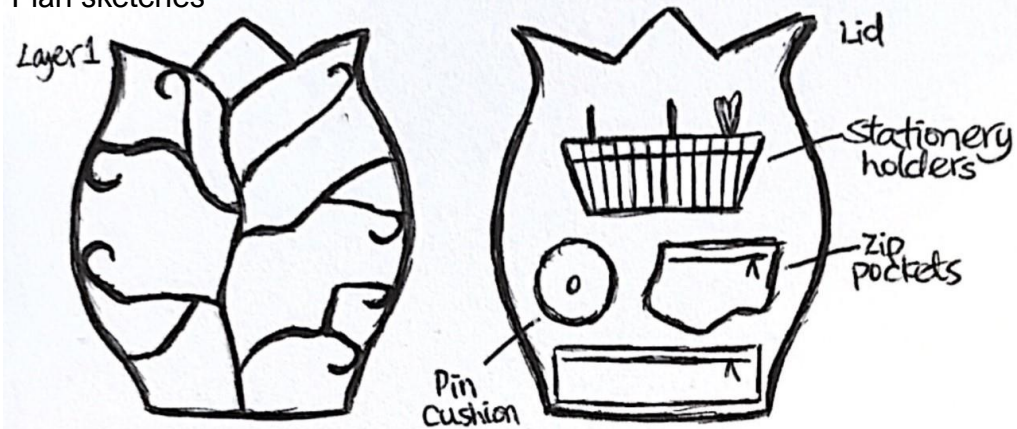

Perspective sketch of the storage layer, in an x-ray's style. This has been drawn in an x-ray (see through) style, so that the interior layout can be seen, and the organisation of the space can be seen more clearly.

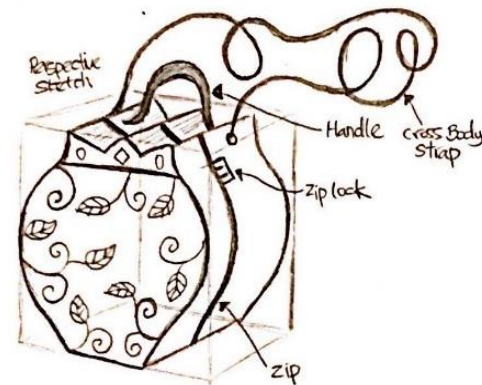
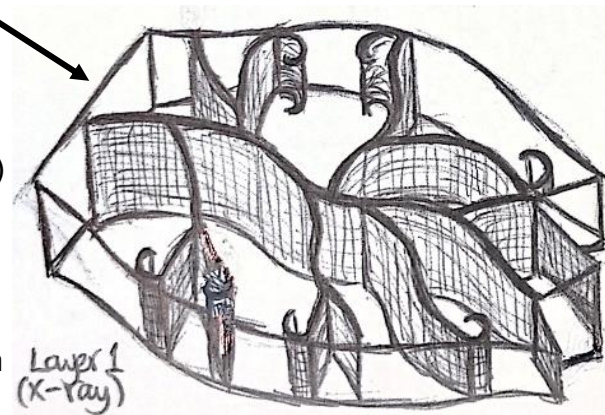

Design 2

Plan Sketches

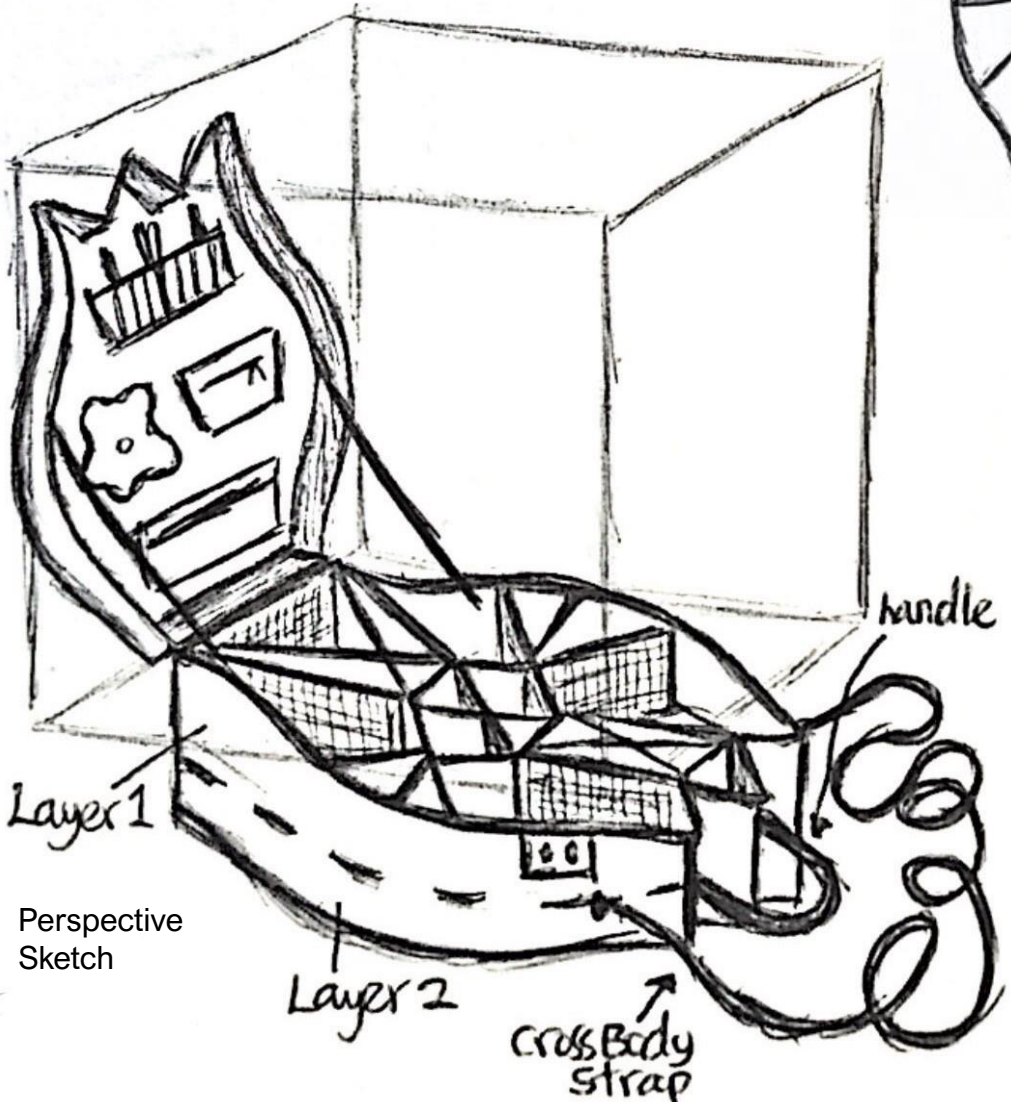
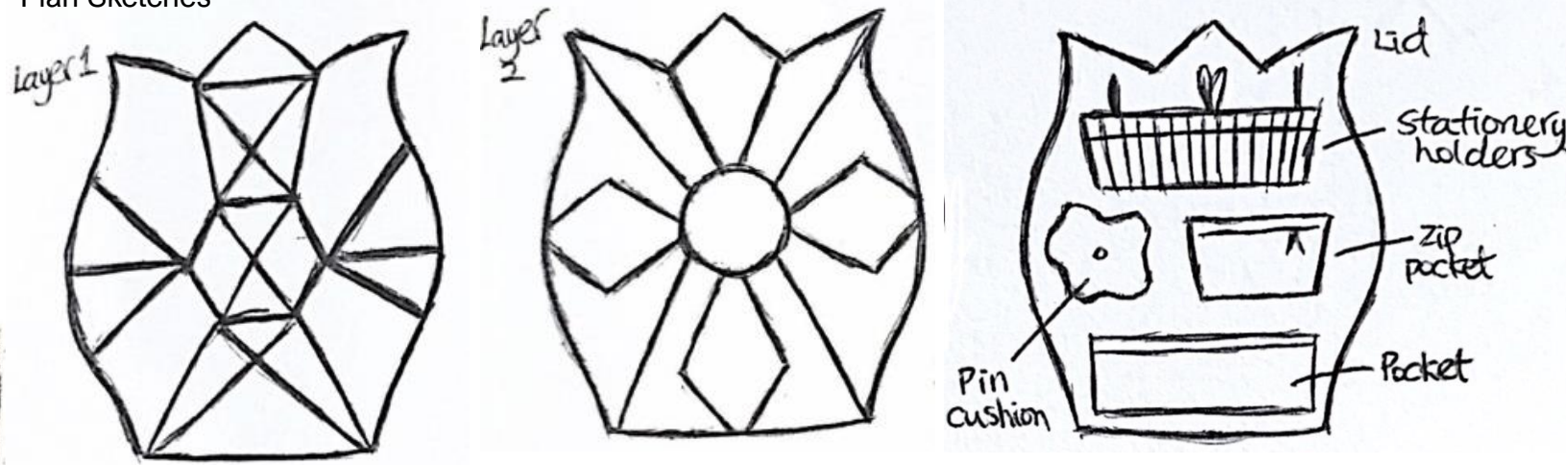

Perspective Sketch

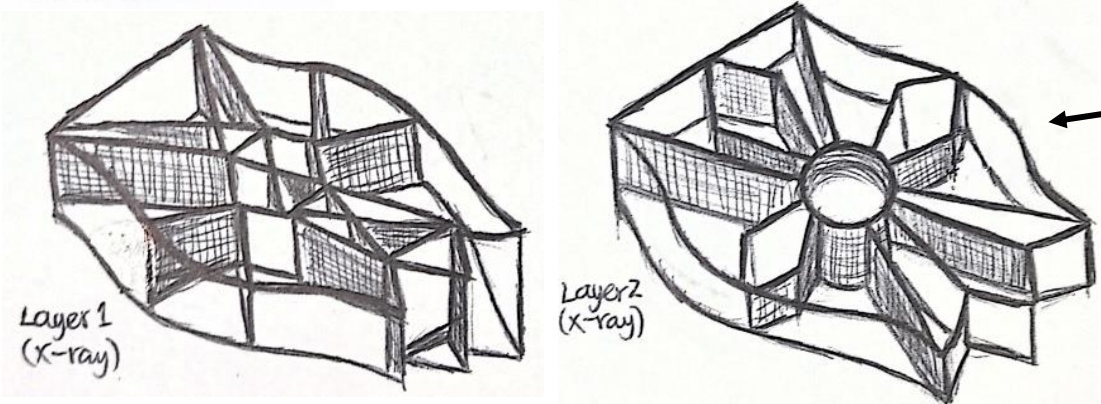

Perspective sketches of the storage layers, in an x-ray's style (see-through), so that the interior layout and organisation can be seen more clearly.

In this design, the interior of the storage organiser has been designed in the geometric style, with a range of different shapes linked together. I have designed two layers of interior layout, as there is going to be two storage layers stacked together in the organiser, one at the top, another at the bottom, which can be taken out by layers. There can be different specialist art equipment stored in each layer, for example, tiny equipment and materials in layer 1, and large equipment and materials in layer 2.

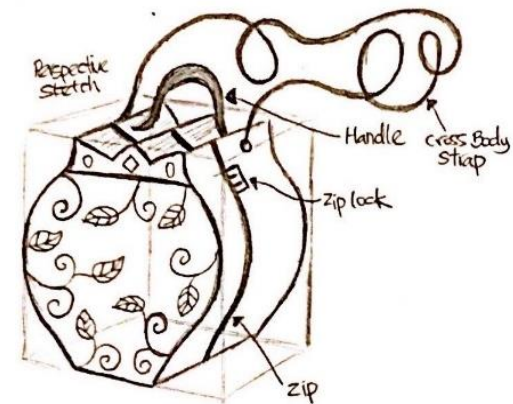

Development: Designing the "Interior Layout" of the Portable Storage Organisers, Sunflower Inspiration

Design 1

In this storage organiser, the interior layout has been inspired by the shape of the round seashell. There are swirling structures designed in the interior space, which separate out the space into sections, with some huge swirling sections, and some tiny swirling sections. Inside the cover of the lid, I have designed a section for the users to store their stationery, and other supplies. The swirling design of the interior layout and the sunflower design on the exterior blends together, which make the design look beautiful and elegant.

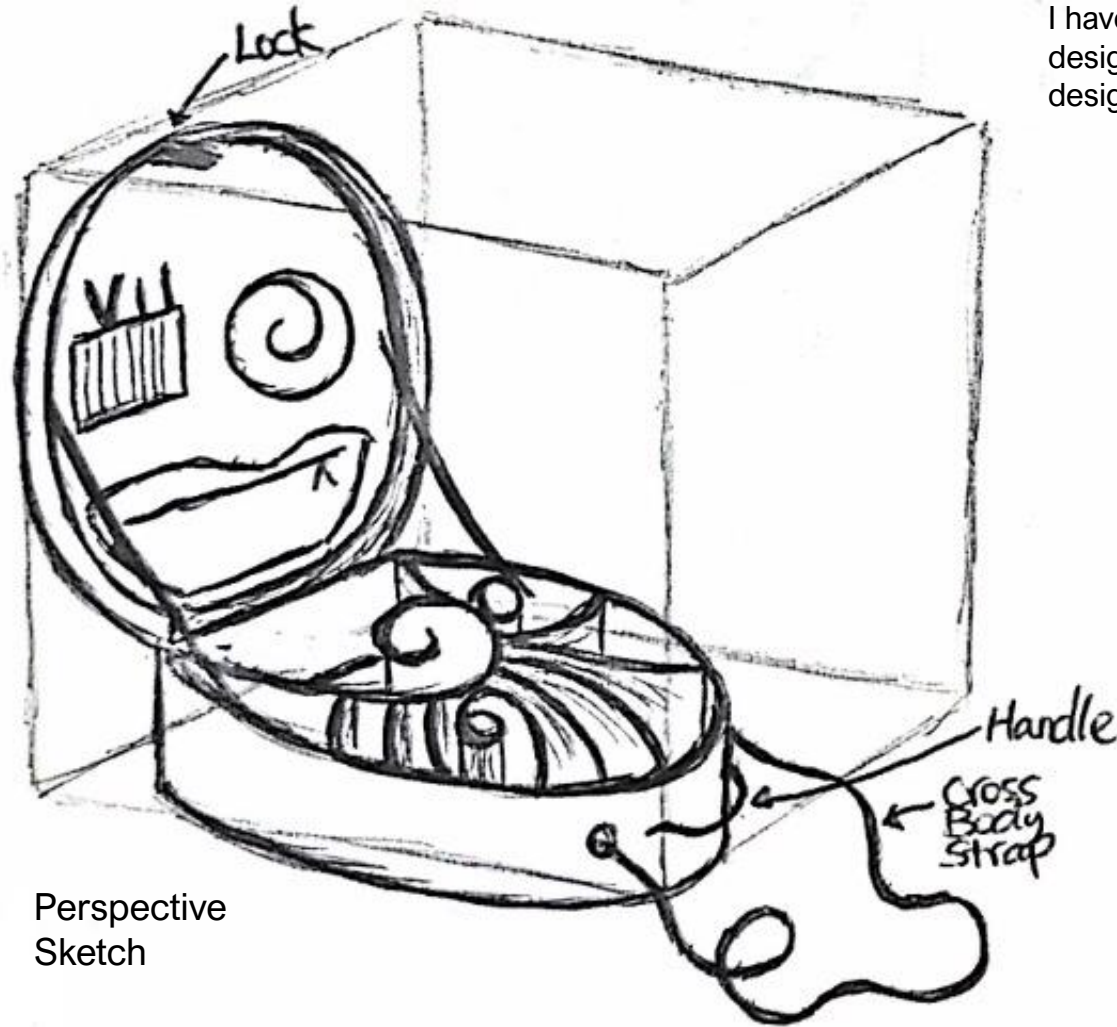

Plan Sketches

Layer 1

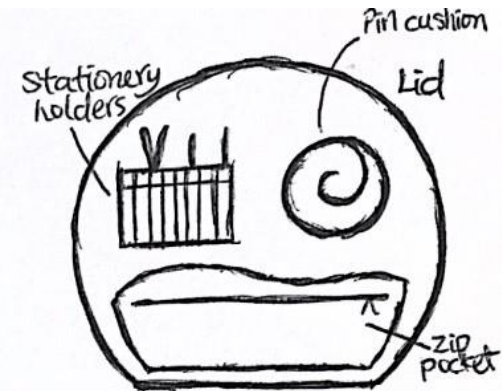

The perspective sketch has been drawn in an x-ray (see-through) style, so that the structure of the interior layout can be seen more clearly.

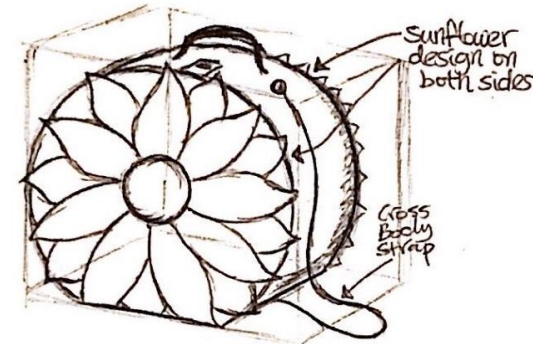
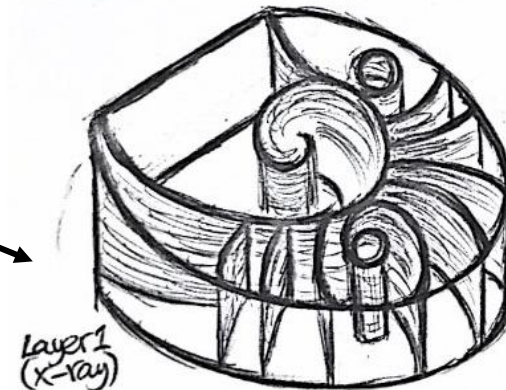

Design 2

Plan Sketches

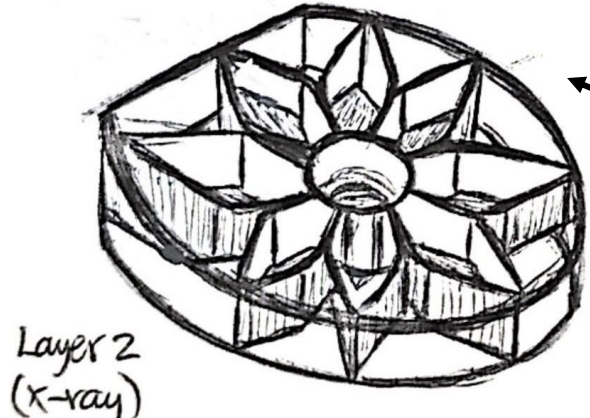
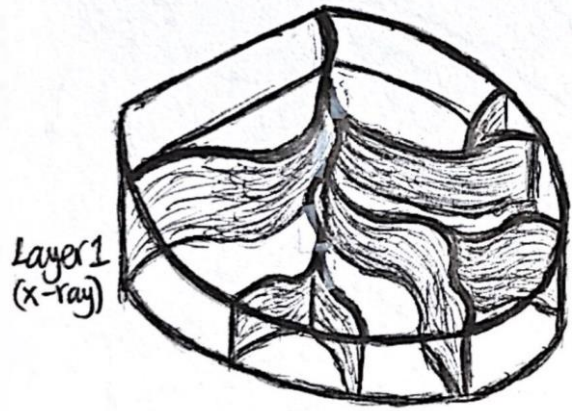
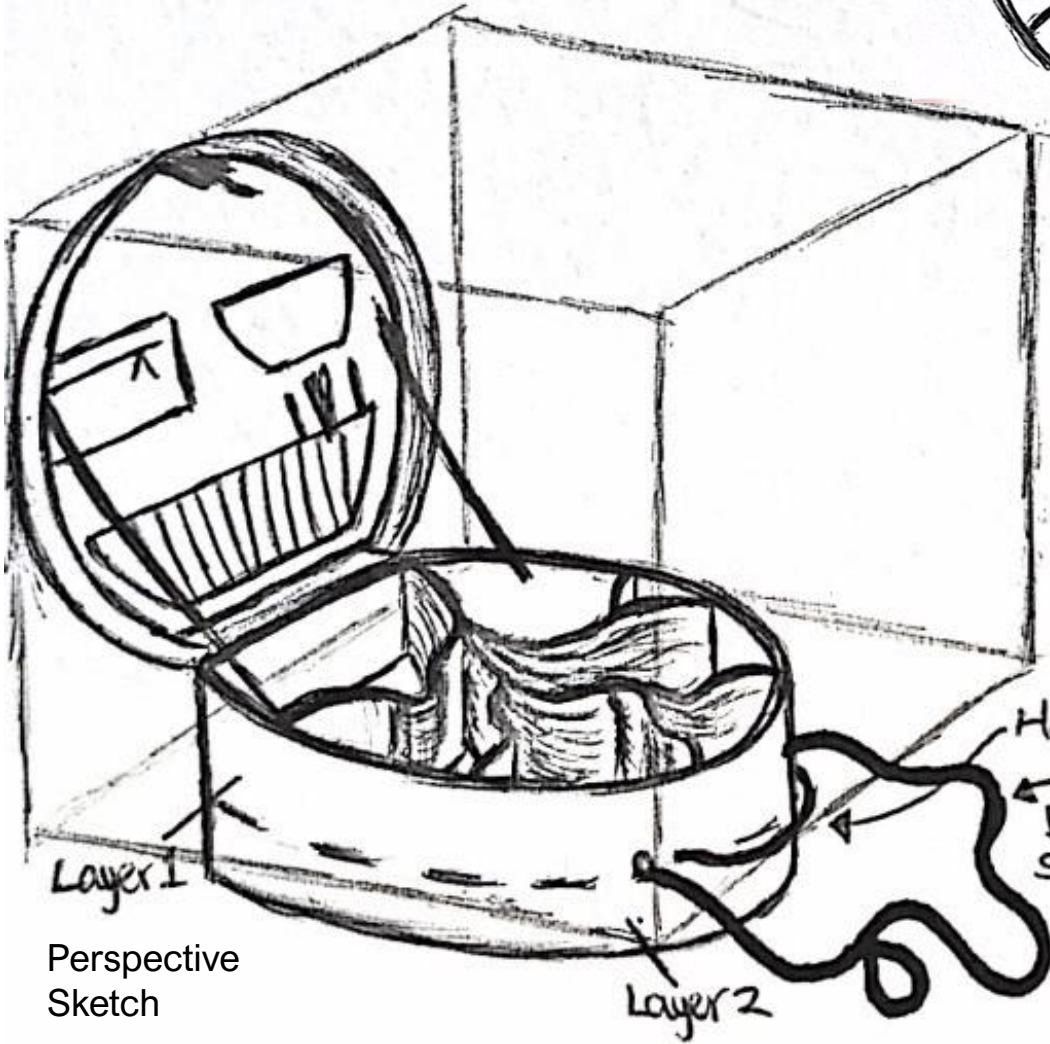
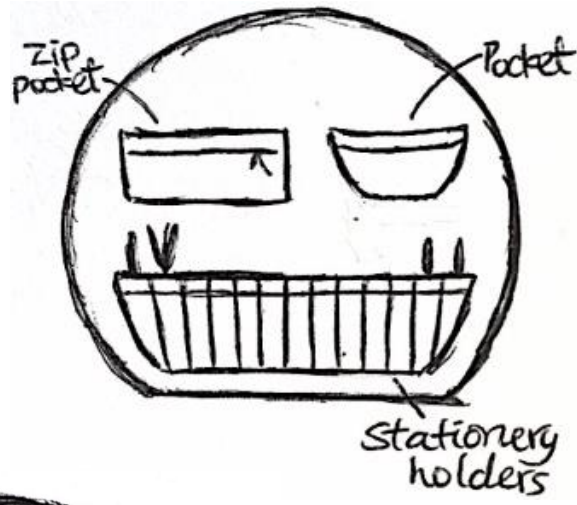
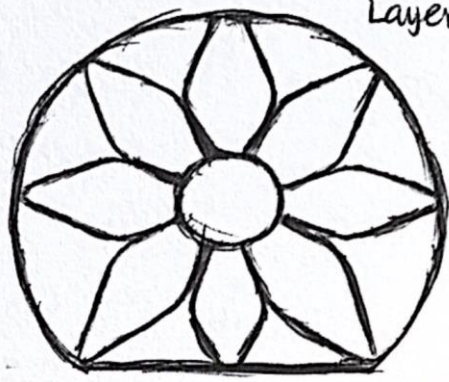
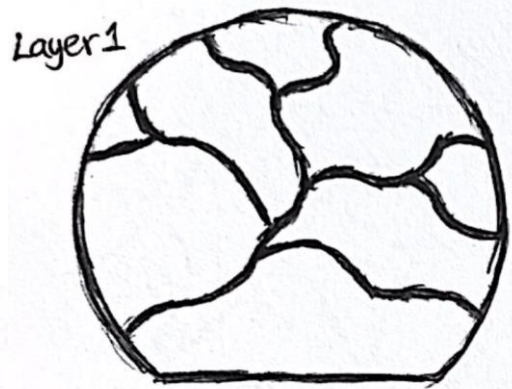

The perspective sketches have been drawn in an x-ray (see-through) style, so that the structure of the interior layout can be seen more clearly.

In this design, I have designed two layers. Layer 1 is designed in the style of a cracked rock, with the cracked structure separating out the interior space into sections. Layer 2 is designed in the style of a flower, with the flower structure separating out the space into sections. For example, the specialist supplies can be arranged in the flower pattern. These two layers will be stackable in the interior space. Inside the cover of the lid, I have also designed a stationery storage section.

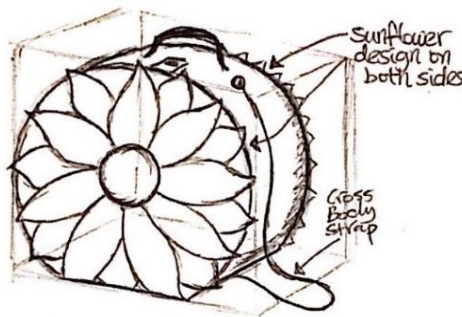

Perspective Sketch

Development: Designing the "Interior Layout" of the Portable Storage Organisers, Leaf Inspiration

Design 1

In this design, the interior layout has been designed in a cheerful style with a range of patterns mixed together, such as a tiny leaf pattern, swirling patterns, and random shapes' patterns. All these patterns are formed into structures, and separated out the interior space into sections. Inside the cover of the lid, I have designed another storage section, including some pockets, stationery holders, and more, for the user to store stuff.

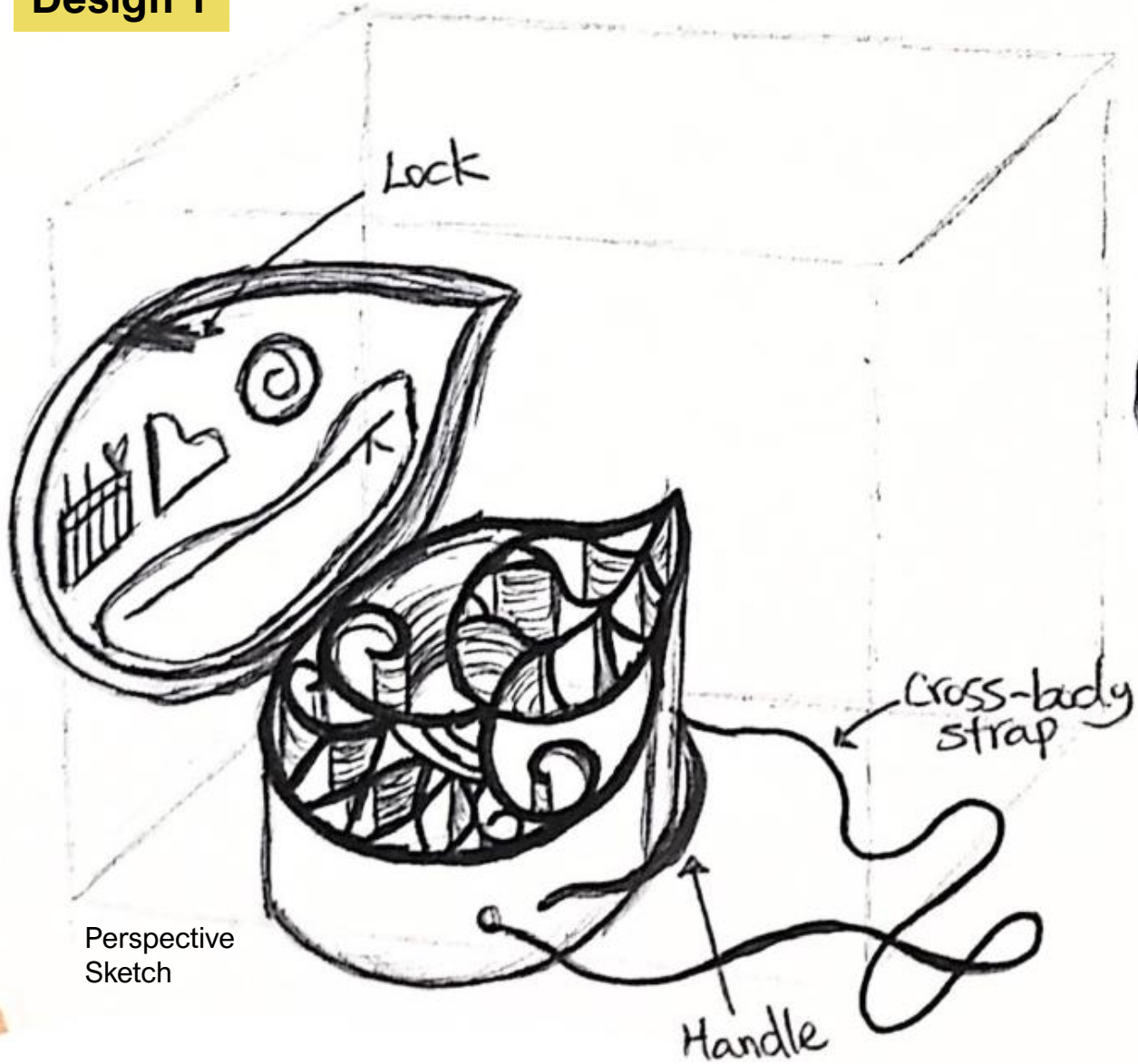

Plan Sketches

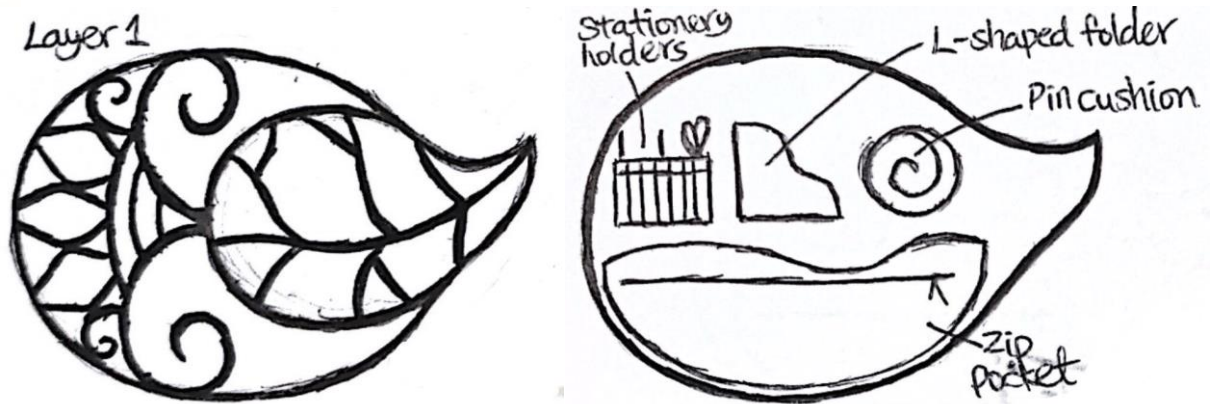

The perspective sketch has been drawn in an x-ray (see-through) style, so that the structure of the interior layout can be see more clearly.

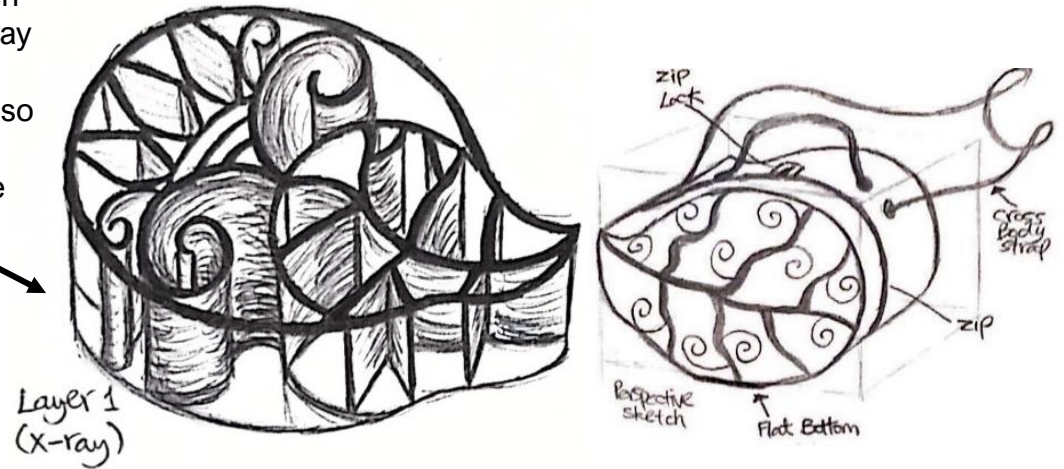

Design 2

Plan Sketches

Layer 1

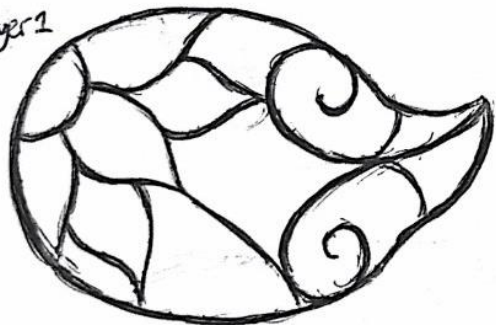

Layer 2

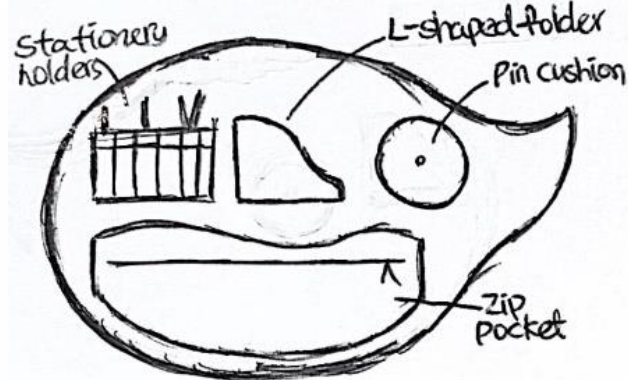
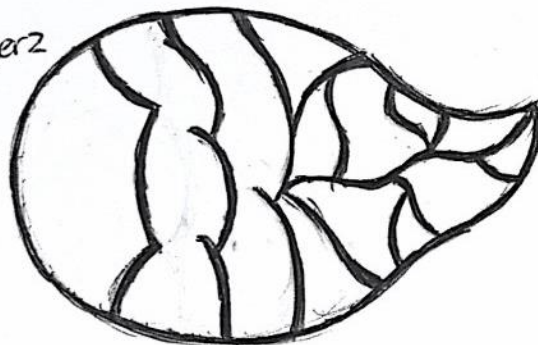

Perspective Sketch

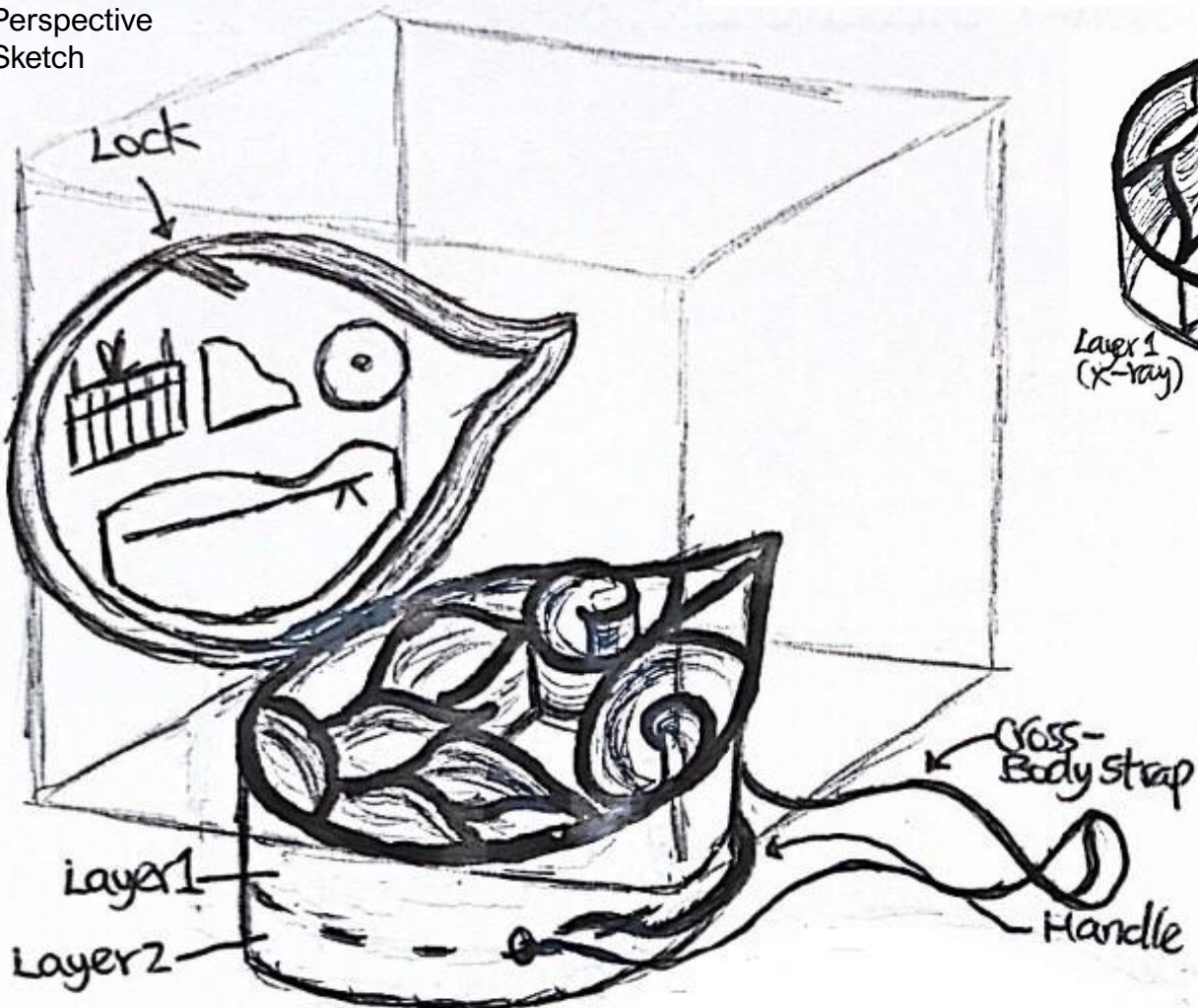

Layer 1 (x-ray)

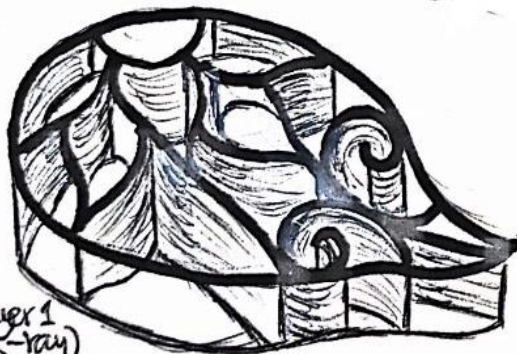

Layer 2 (x-ray)

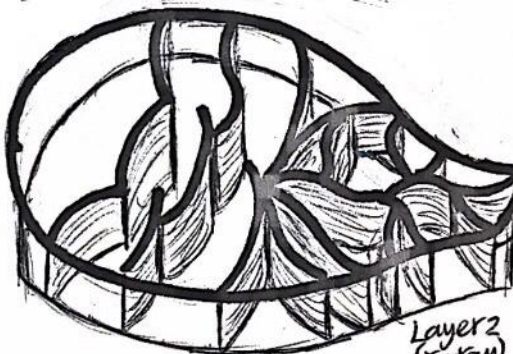

The perspective sketches have been drawn in an x-ray style.

In this design, I have designed two lovely layers. Layer 1 is designed in the style of a garden, with a mix of beautiful flowers, branches and leaves. Those beautiful garden structures will separate the space into sections. Layer 2 is designed like a feather, with the feather design structuring out the space into sections. The two storage layers will be stackable. I really like this design, as the interior garden and feather design blends in well with the exterior leaf design, which makes the organiser look natural and charming.

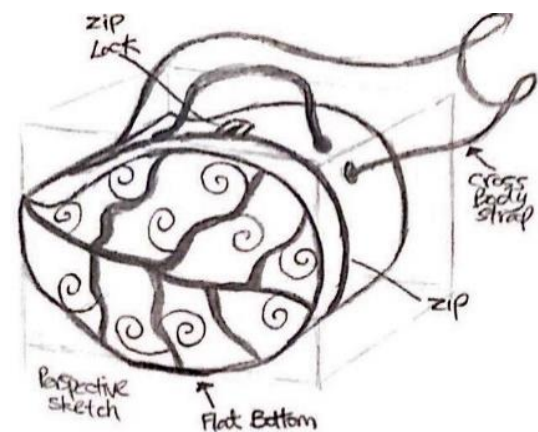

Design of the "Protection Layer"

To be structured in between the lid and the main storage area, which can be opened and closed.

I have designed a "protection layer" for the storage organiser. The "protection layer" is a thin layer to be structured in between the lid and the storage area. The "protection layer" is like a lid, which can open & close, with a ribbon designed in the front, so that it's easier to open. →

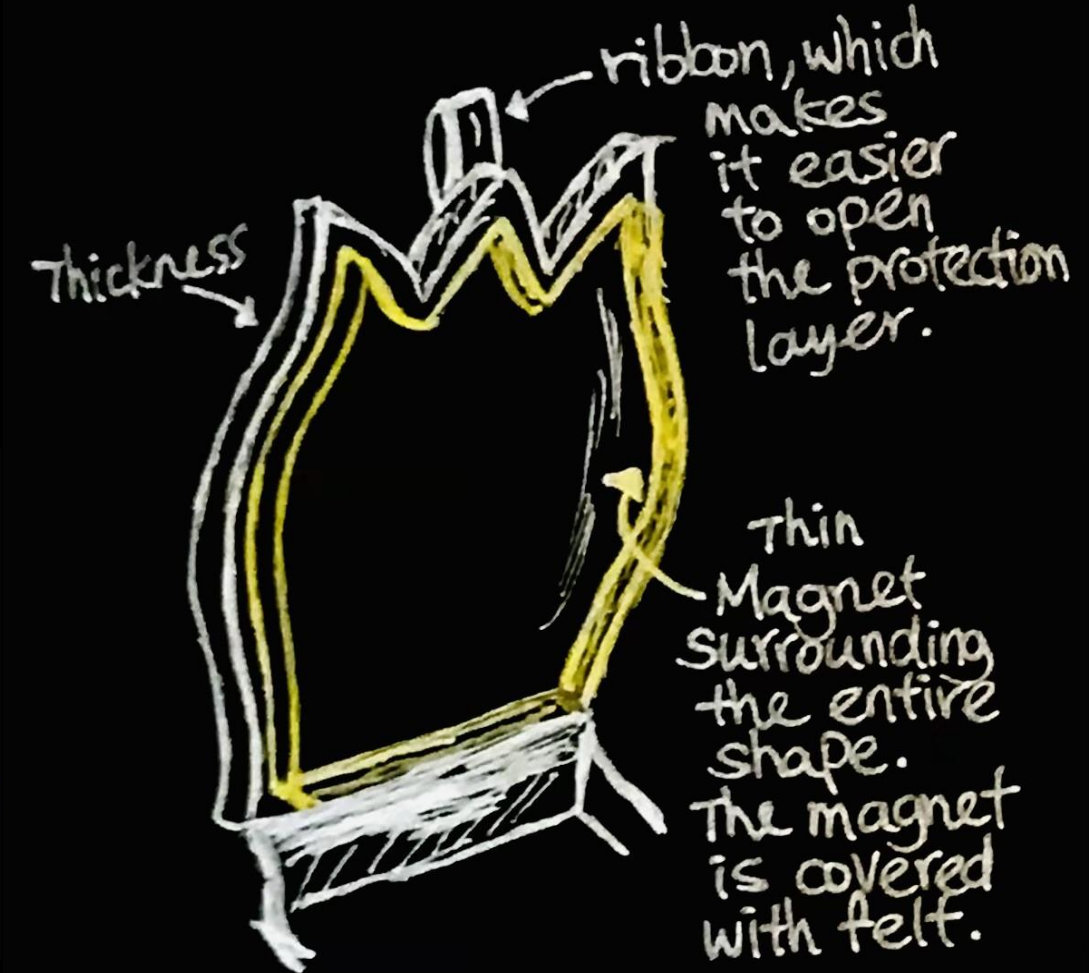
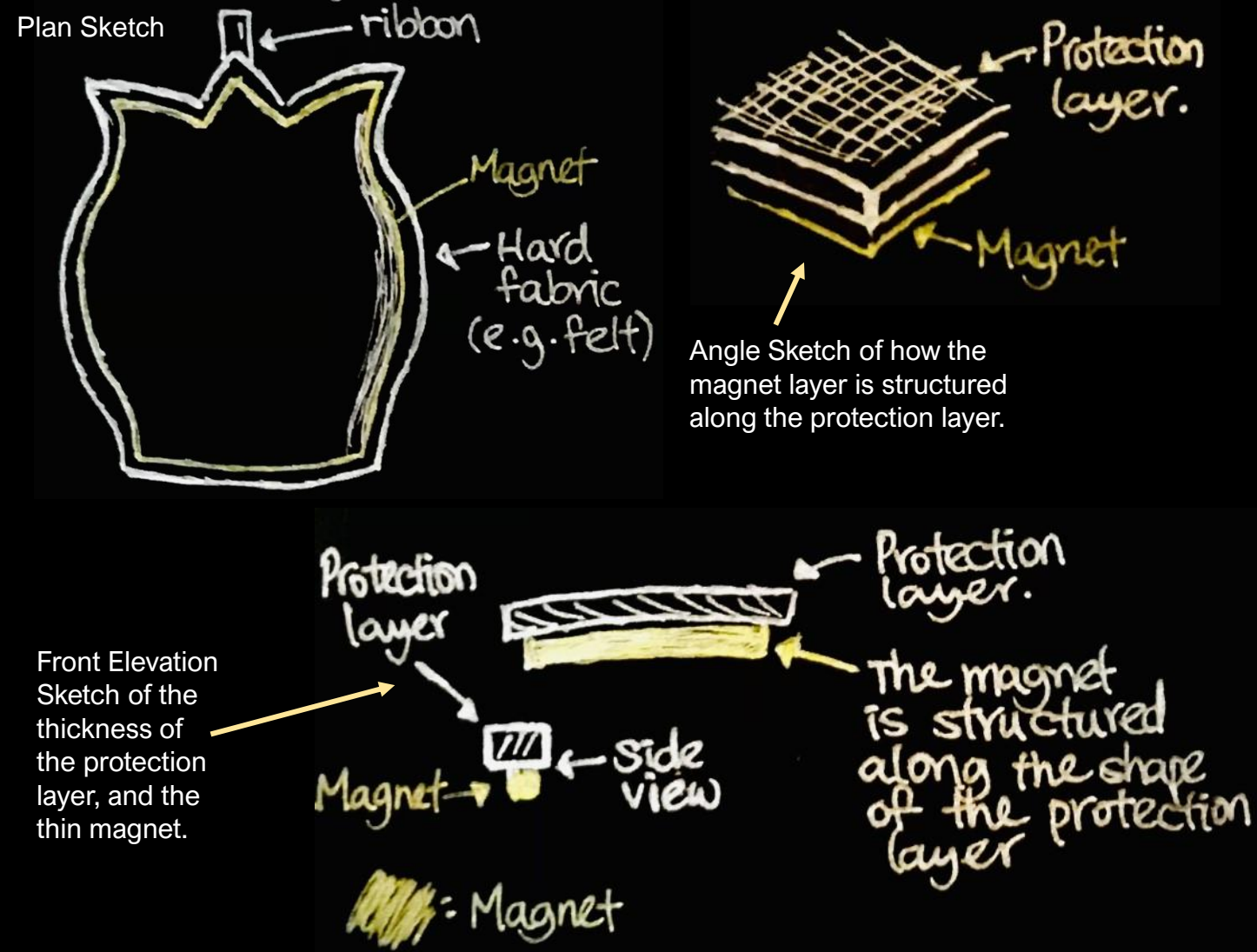

The reason I have designed a protection layer with thin long magnet attached along the shape is that it can secure the art supplies in the storage area when the magnet attracts to the other long magnet along the top edges of the storage area. This prevents the art supplies (objects in the organiser) getting disorganized or messy, when organiser is being hold on the handle or on the cross body strap.

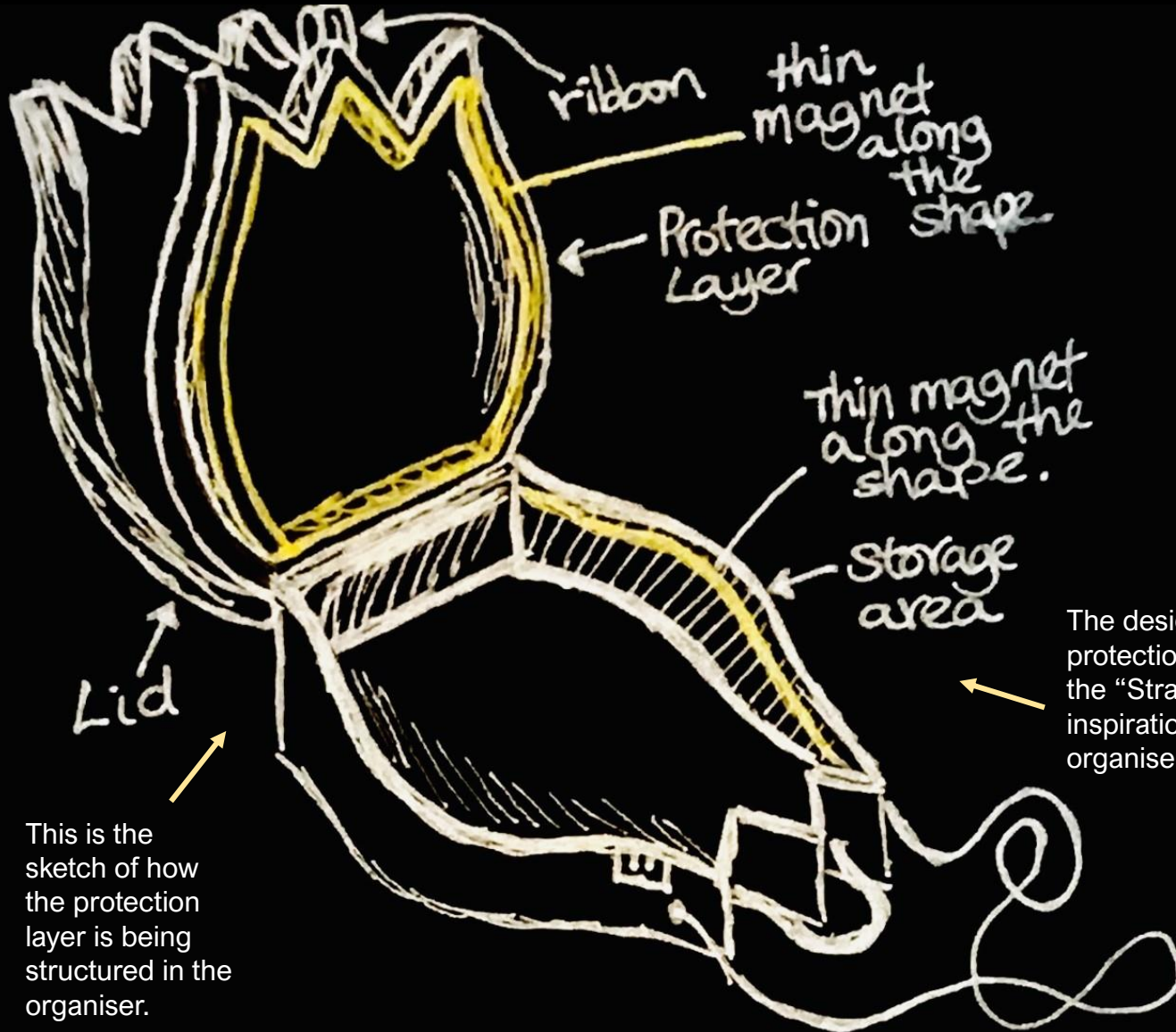

This is the sketch of how the protection layer is being structured in the organiser.

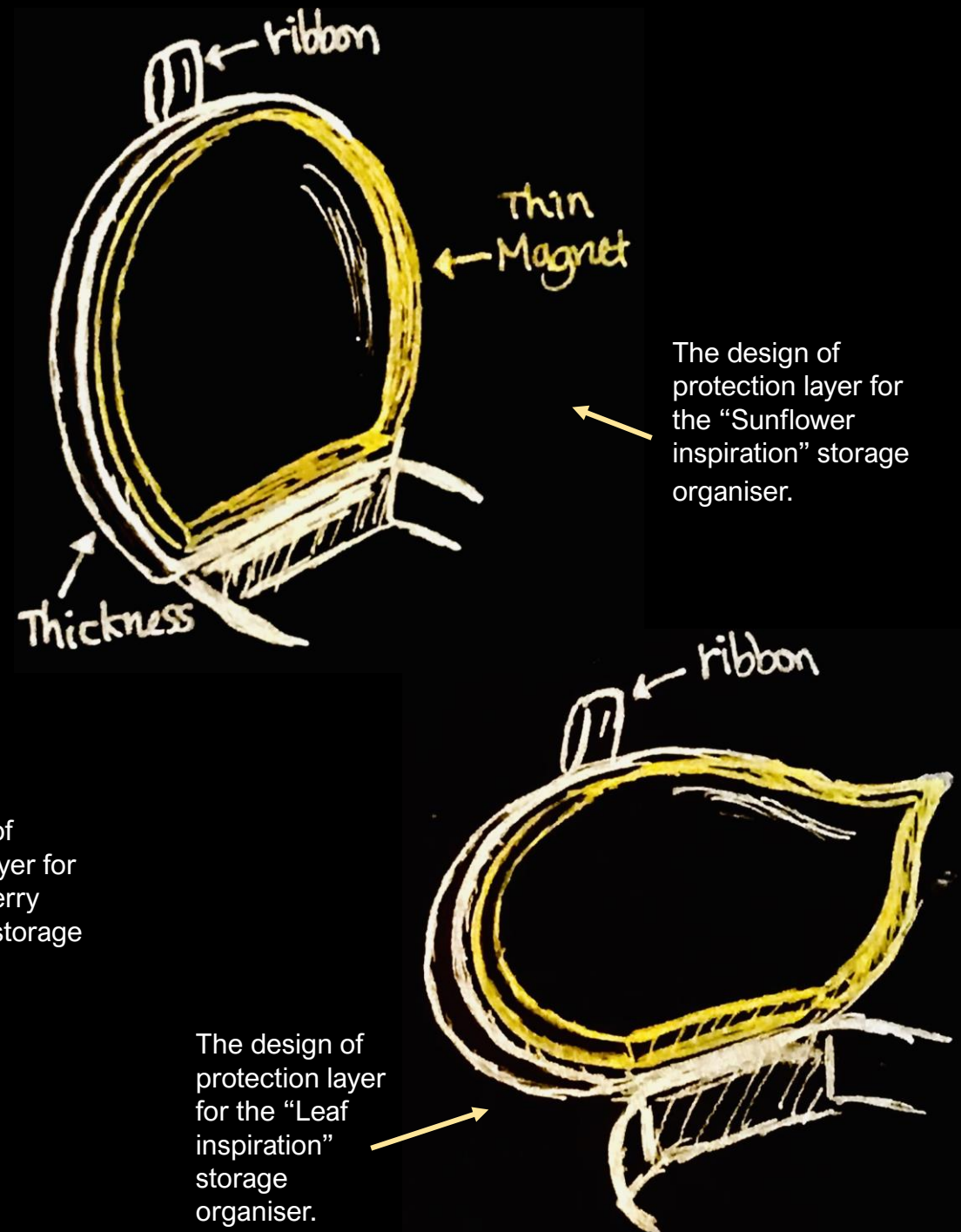

The design of protection layer for the "Sunflower inspiration" storage organiser.

The design of protection layer for the "Strawberry inspiration" storage organiser.

The design of protection layer for the "Leaf inspiration" storage organiser.

Recording My Development (Scale-Up): Apply Slotting Techniques to the Portable Storage Organiser Design, Strawberry Inspiration

Stage 1: Building the Exterior Structure

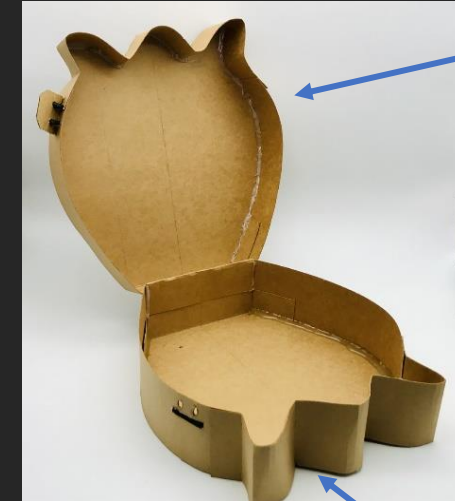

Lid

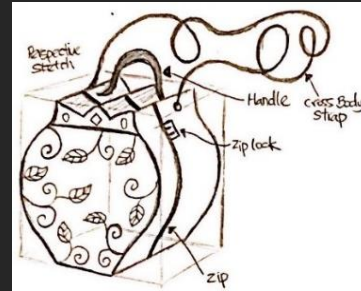

Main Storage Area

Slotting technique

Stage 2: Building the Interior Layout

In the interior storage space of this model, I have used the "slotting technique" to construct the interior layout. The interior layout has been constructed into the style of swirling branches, using thin cards, which turn the huge space into sections of storage spaces.



Stage 3: Constructing the “protection layer”, the handle, and the cross-body strap.

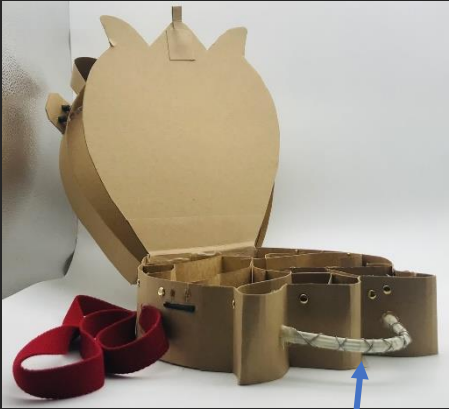
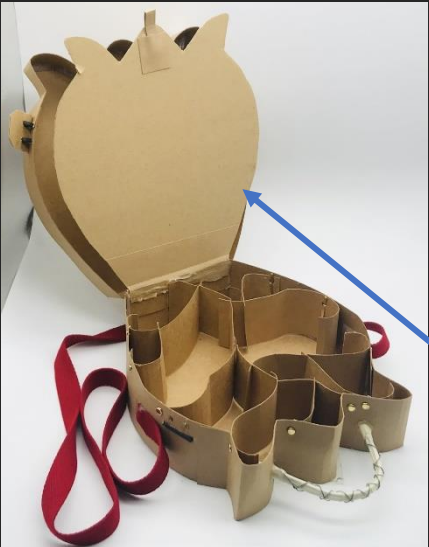
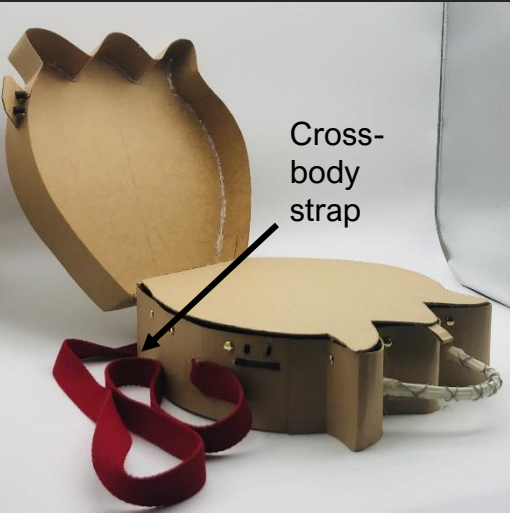
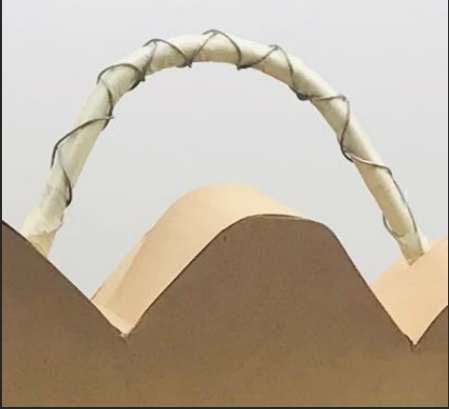

This storage organiser has been made using a range of materials, which are thin cards, cardboards, thick & thin wires, and a long strap. I tried to make the locks on both sides of the storage organiser, but they didn't work out, therefore, I need to make some improvements. Making this storage organiser let me start to understand what parts I need to improve, as they do not work well. For example, I think I need to remake the cross-body strap, as when I'm holding it, the organiser kept moving around, not staying in the straight position. After making this model, I started to think about how can I make this into a better design.



Theme: Natural & Organic



Crows Bones



Acorn nuts

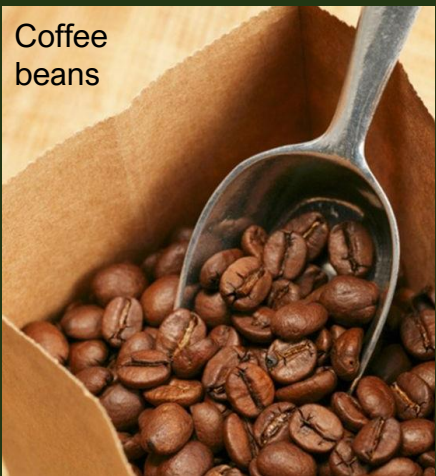

Coffee beans



Dried Leaves





Secondary Research: Idea 2

User: Professionals
Products: A range of working furniture.



Secondary Research: Working Furniture 1

After doing some research on this desk, I have learnt different ways to save spaces, for example, the design of the lid with storage spaces under it in the desk surface, the stationery pots structured in the desk surface, and drawers on the sides of the desk are ways that can save spaces, but also make the desk look nice. Therefore, this desk design has taught me on how to save spaces but also make the desk look attractive, with a nice looking.

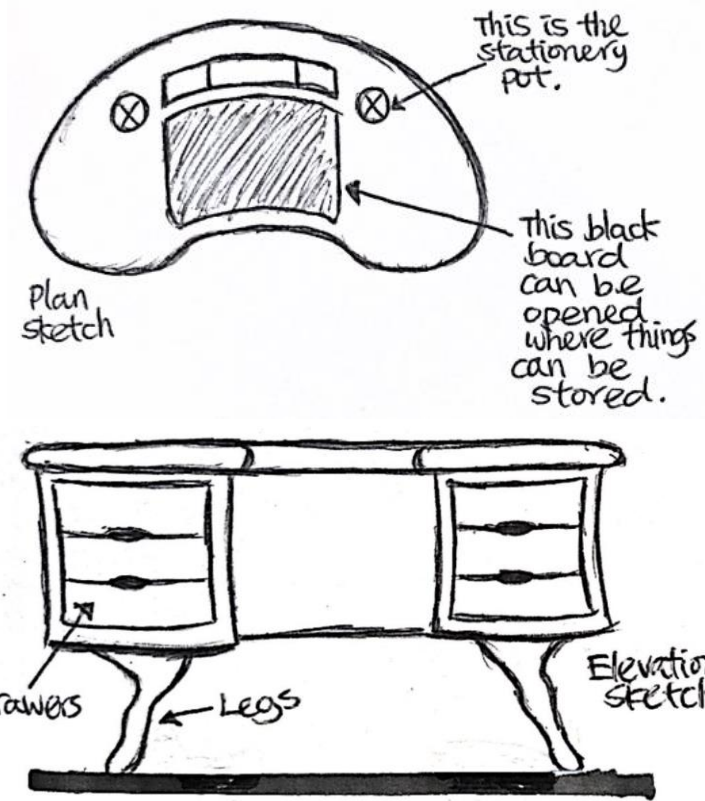
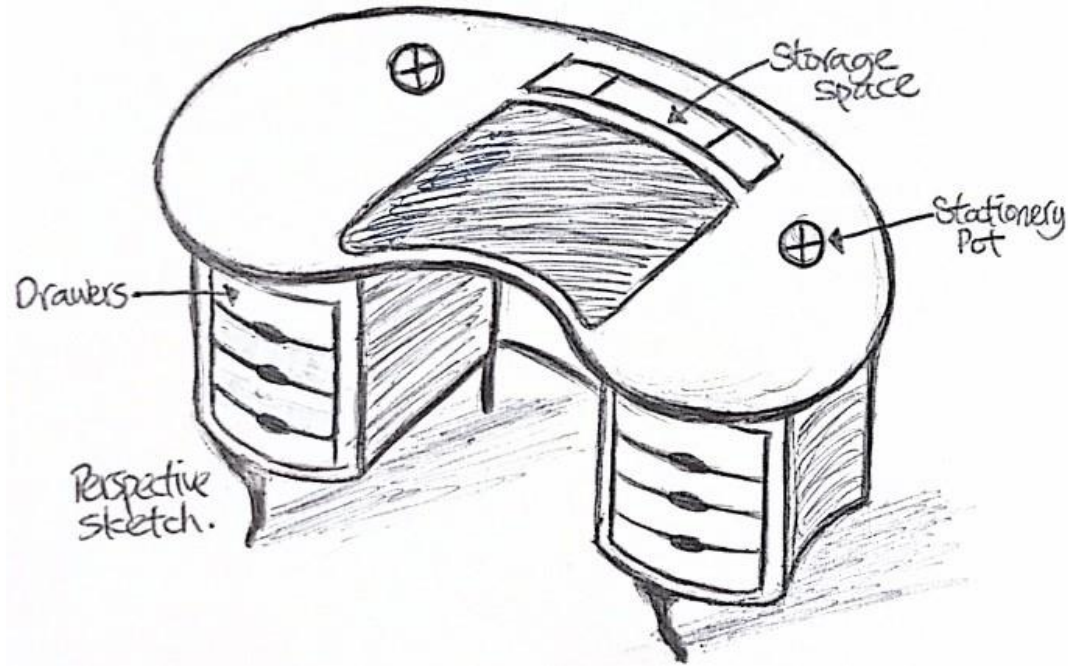

This desk is a utilitarian design, which saves a lot of spaces. I like the way that the desk is designed, which saves spaces, and keep things organised. For example, when the user needs a notepad, it can just open the desk lid to get the notepad, and then close the lid, where there is smooth table that the user can work on.



This is the storage layer, which is designed as the same thickness as the desk, and being structured in the desk, with a lid on top, so that the user can close it.

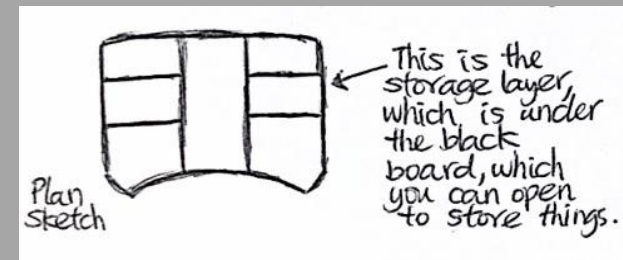

Experience on Working Furniture 1's Developments

These are the designs that I have experienced sketching, which have let me understand how the function of the table works, and how to save spaces.

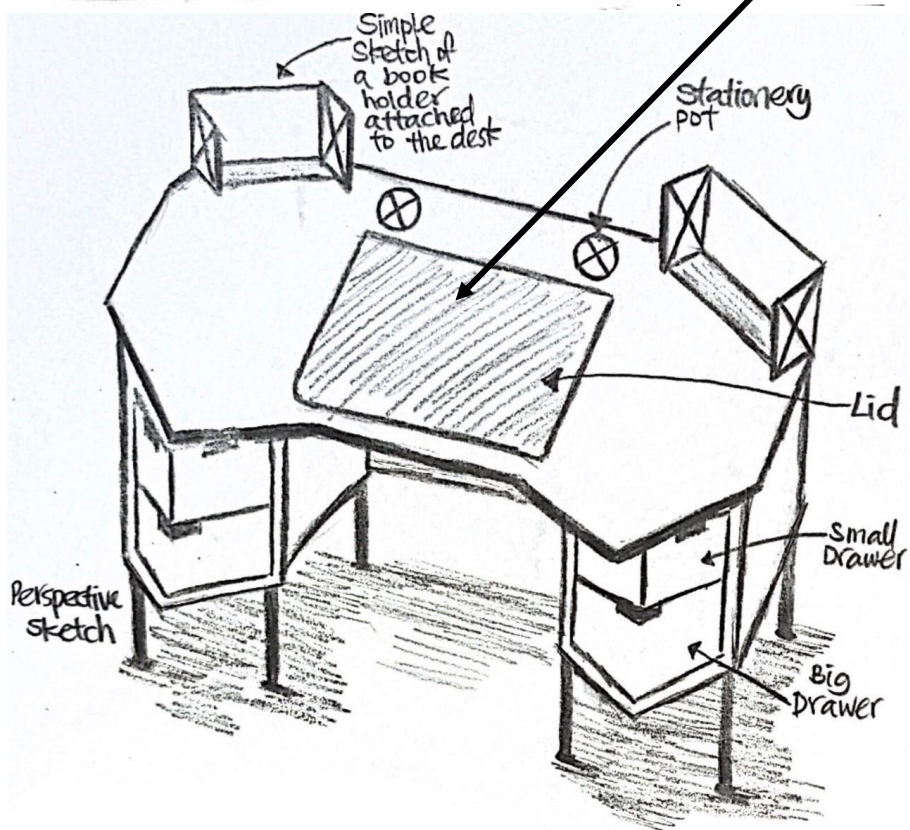
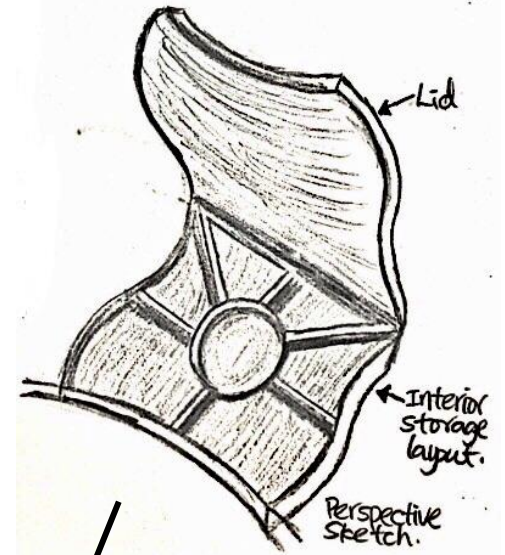
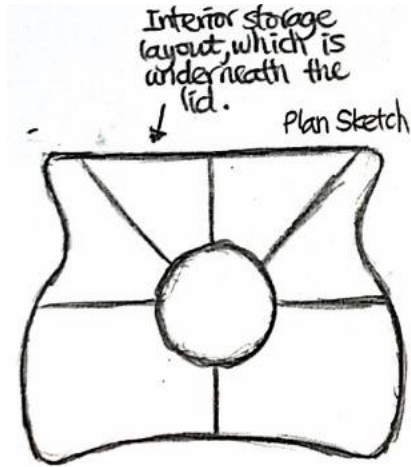
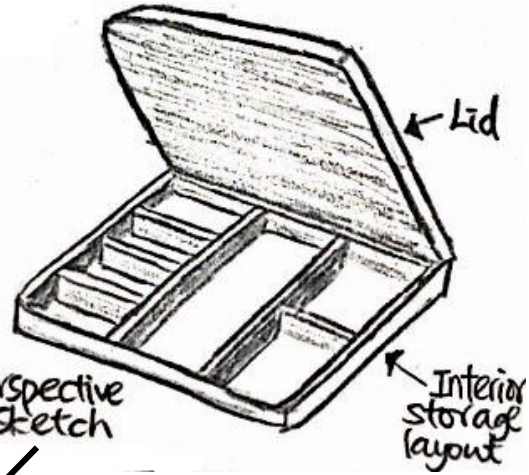
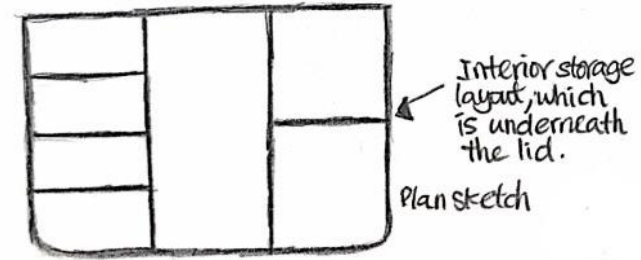

Sketching out these desk developments have taught me different ways of designing the desk surface and save the spaces on the surface, so that the user will feel comfortable when doing work on the desk. For example, I have developed book holders on the desk, so that the user can store books in an organised way, and it will also be easier to find the books the user want, rather than stacking books on the desk. I have also experienced designing storage cupboard and drawers on the desk's legs, so that this can save spaces, and make the users feel easier to find or store things.

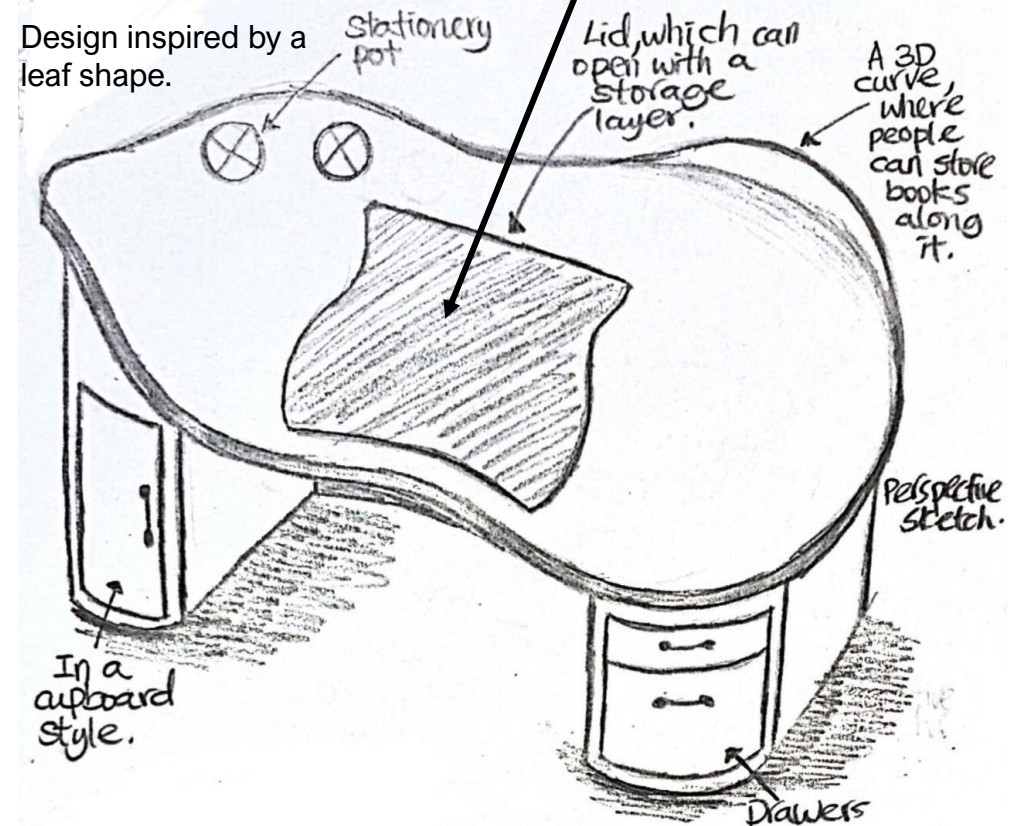

Secondary Research: Working Furniture 2

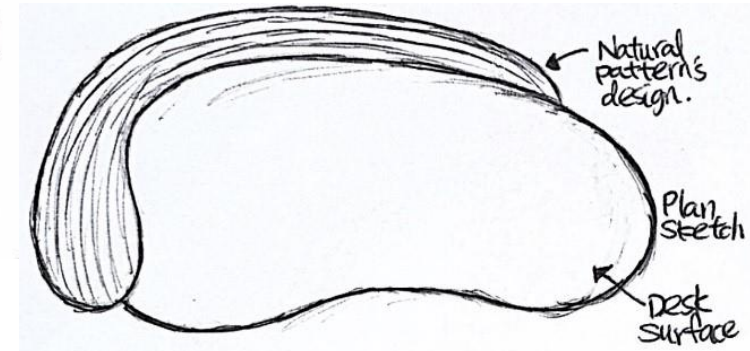
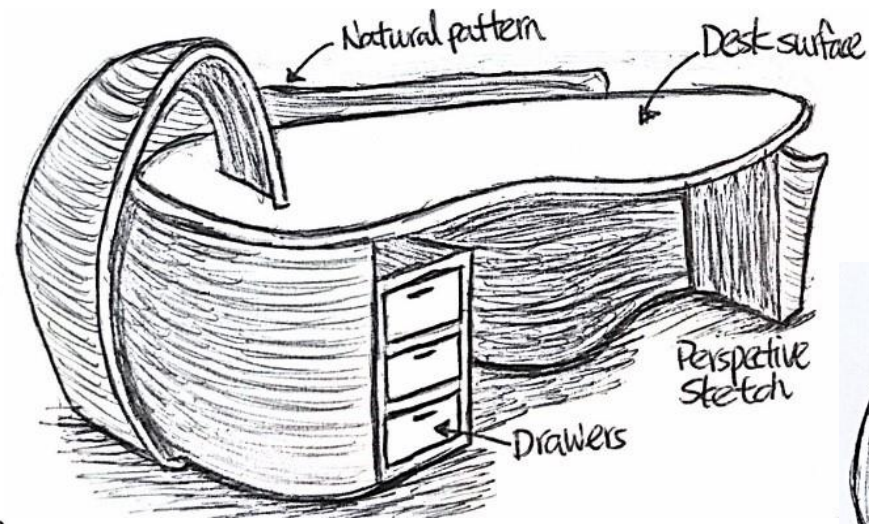
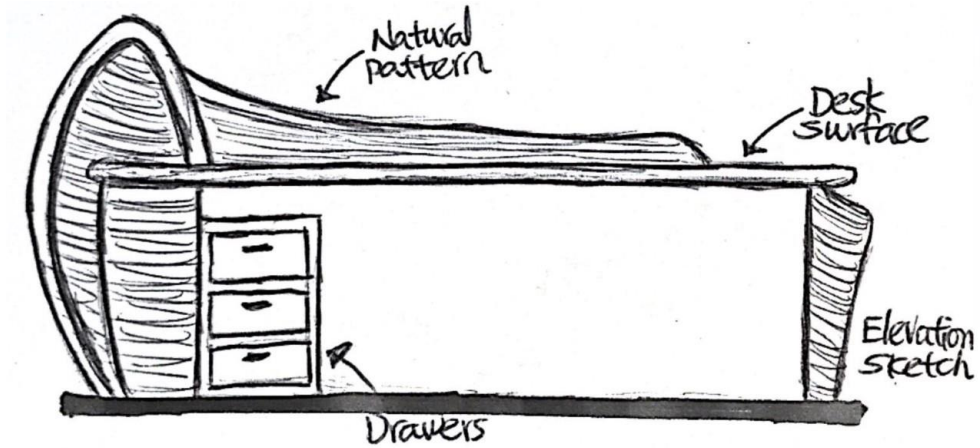

Front view



This desk is formed in a random shape, with the combination of natural pattern. For example, some parts of the desk are curved randomly. The reason I like this desk design is that the natural shaping of the desk can express the feeling of freedom. And I also like the drawer being designed with the desk, which makes both of them blend in, rather than just taking a random drawer and put by the side of the desk.

Back view



This desk design has given me tips on how to design desk in a random & natural shaping, but with more functions, as the desk only have a section of drawers. If I was to design a desk, I will design more functions to save spaces, which can make the atmosphere look better. For example, a cupboard, a stationery pot and a book holder section.

Experience on Working Furniture 2's Developments

I have experienced designing a desk in a random & natural shape, but with ways to save spaces. In this design, I have designed a desk with the combination of a cupboard, drawers, and an L-shaped cupboard, which can give the user the spaces to store stuff, rather than putting things all on the desk, which can be uncomfortable to do work. Developing this desk has let me understand how to design a beautiful desk with several ways to store stuff.

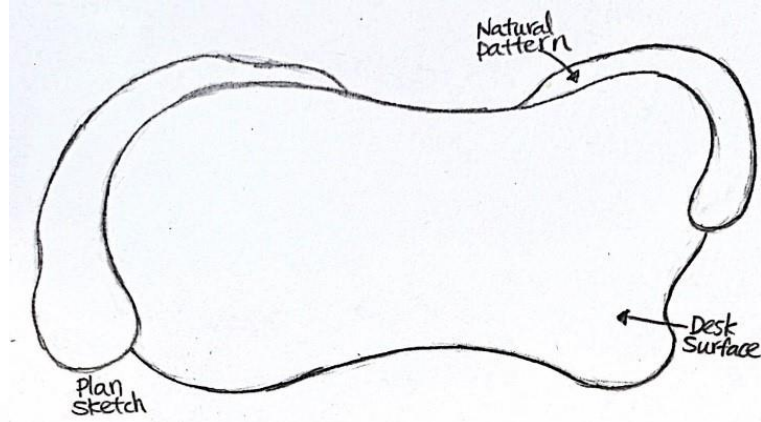

This desk design has developed my understanding on how to save spaces through the design of a desk. I really like how I've created different types of storage spaces in the desk design. This design has taught me that as long as there is a product, I can always use my critical thinking to work out ways to save spaces, and also make the design of the product look amazing and spread emotions.

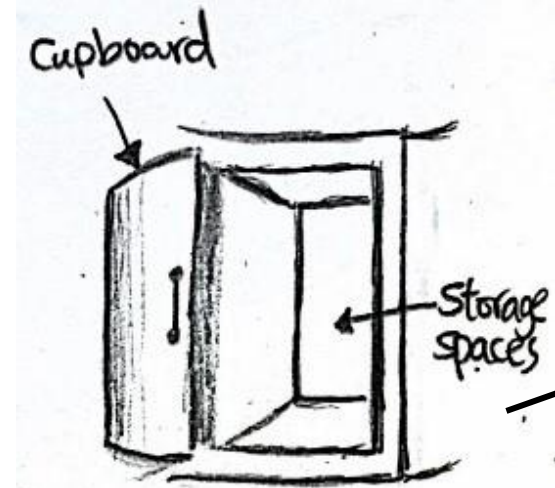
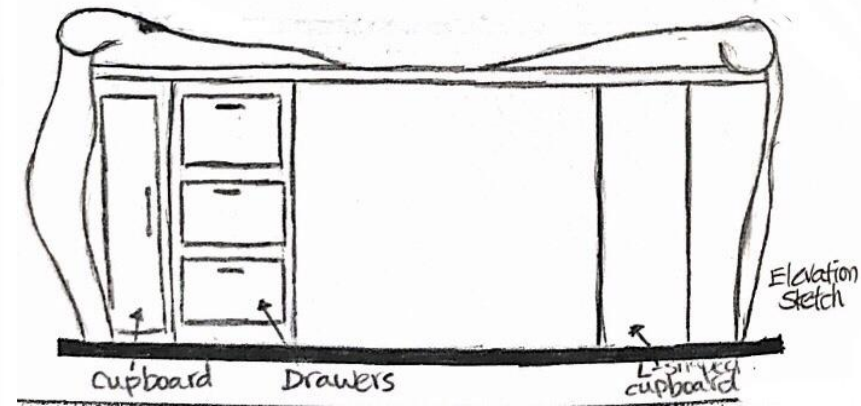
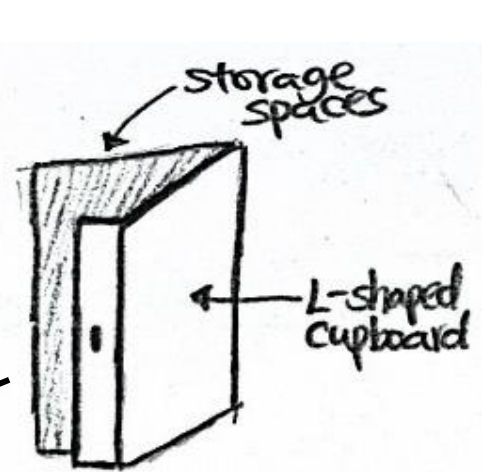
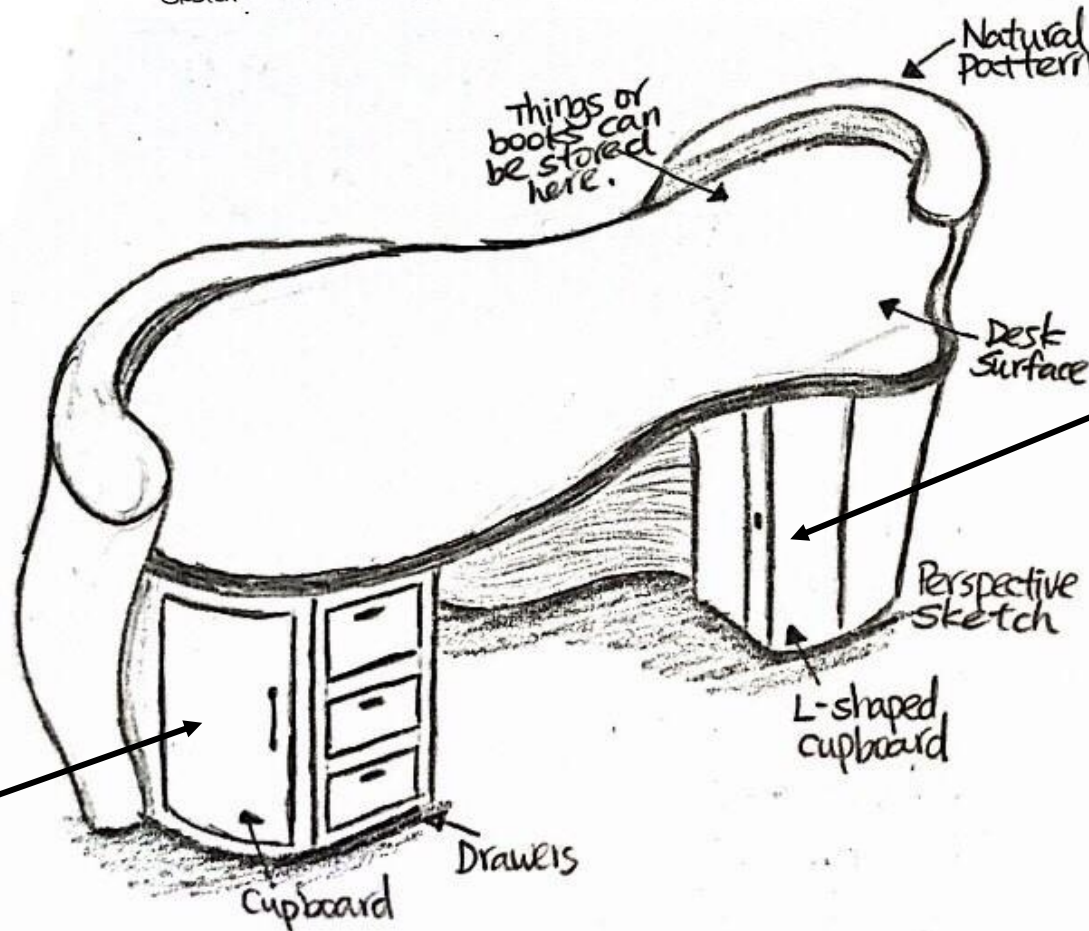

Dried foods



Sunflower



Egg shells



Bone

Primary Research: Natural & Organic



Seashells & Organic Species



Plants



Crystals Tree

Orange Segments



Apple slices

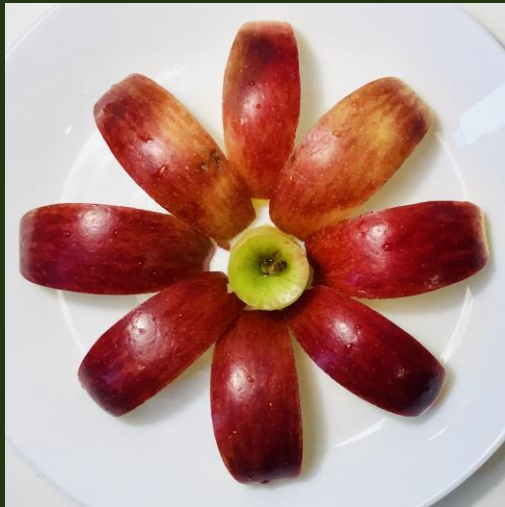

Primary Research: Natural & Organic

Lemon

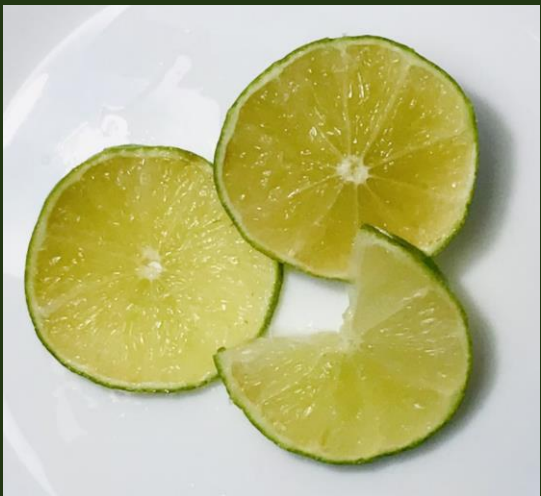
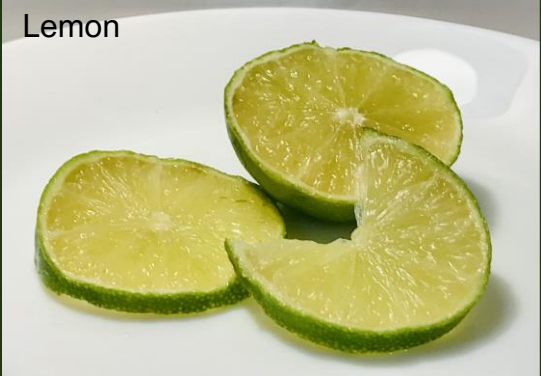

Sunflower's leaf



Flowers & Leaves



Ideation: Generating Ideas for Desk Designs

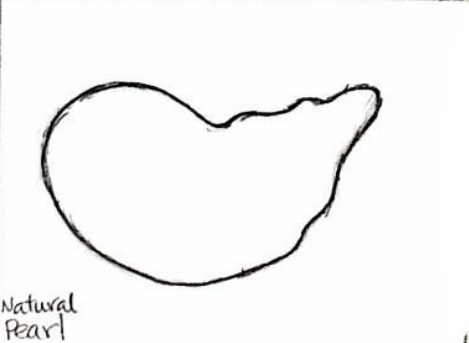
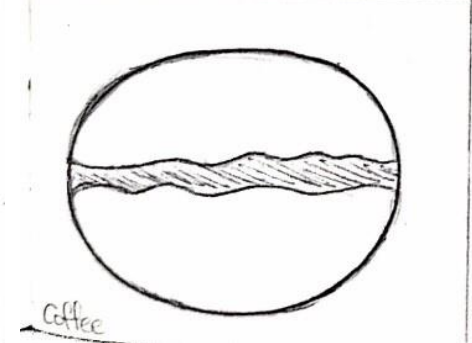
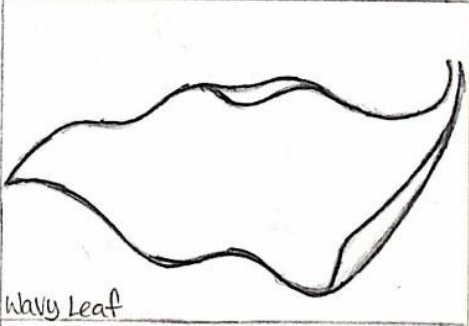
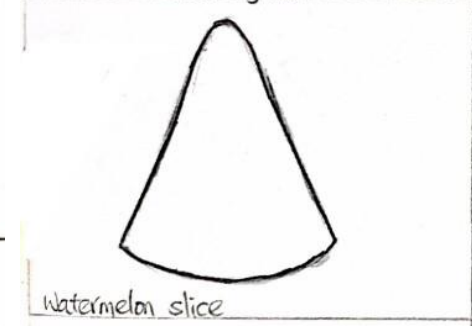
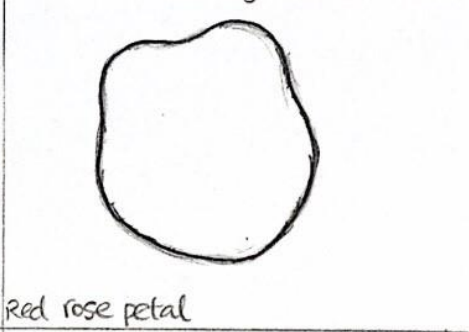
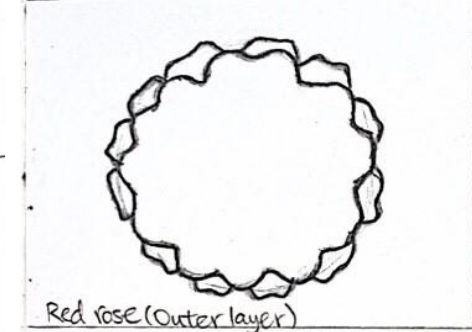
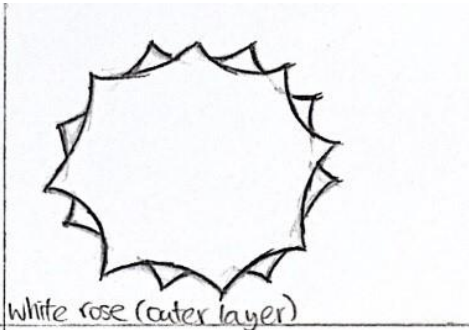
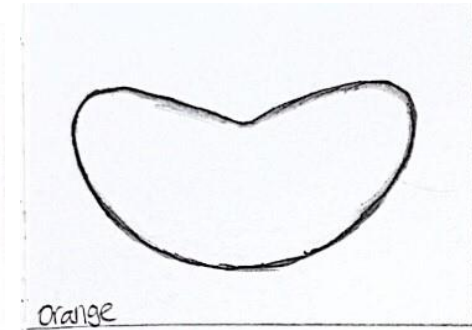
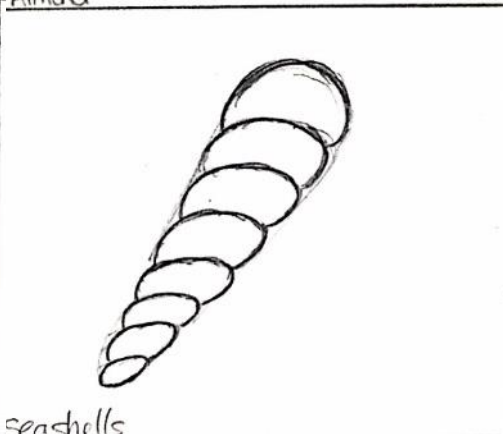
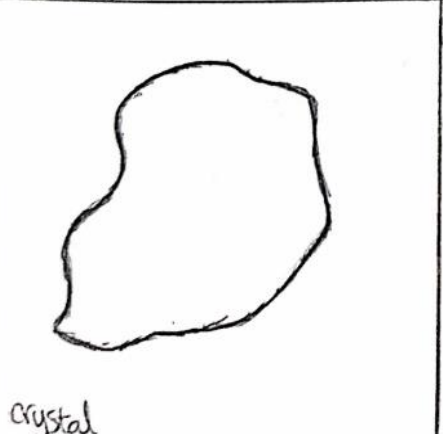
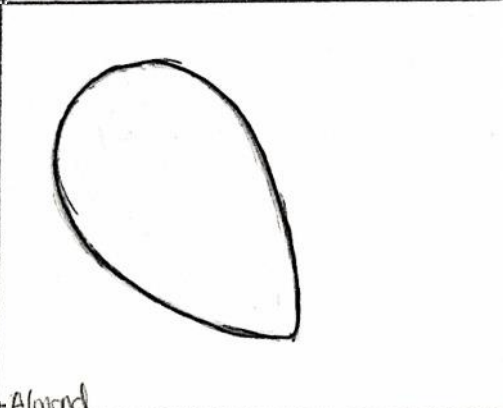
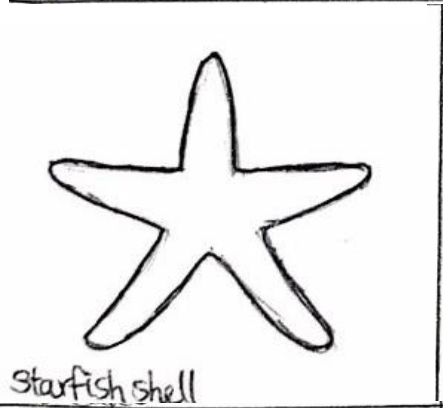
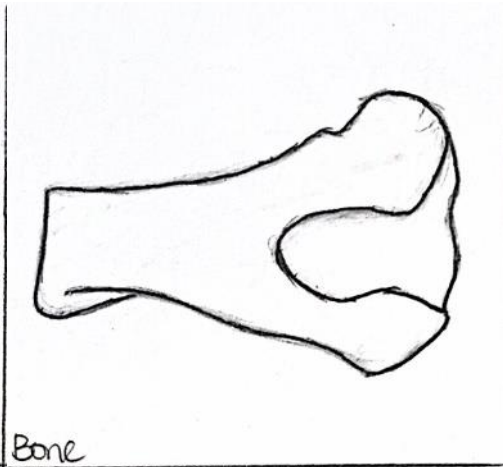
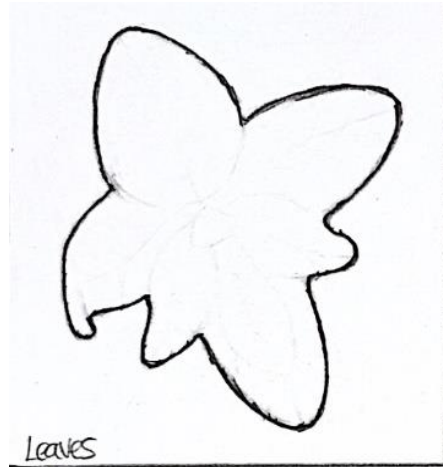

I have simply outlined the shapes of the "natural & organic" items. This gives me a rough idea on how the shapes are formed, and what kind of patterns and shapes are related to the theme. For instance, I have outlined the shape of the bone, without adding details on it.

During the process of outlining different shapes, I started to get an experience on combining different shapes together to form different variation of desk designs. This can make the desk designs look more interesting and natural.

Primary Research Photos



Apple slice



Dried banana crisps



Egg shell



Lemon slice

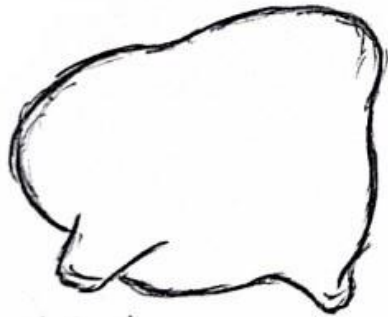

Natural Pearl

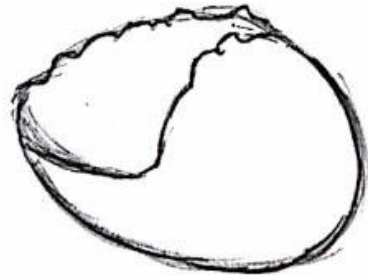

Egg shell

Leaves & Branches



Natural Pearls



Egg Shells

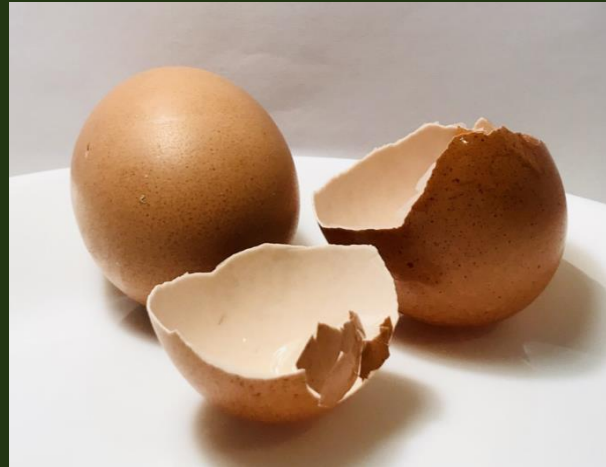

Ideation: Generating 3D Shapes

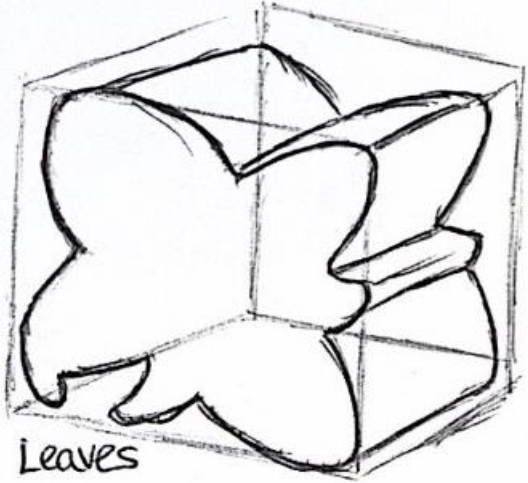

Leaves

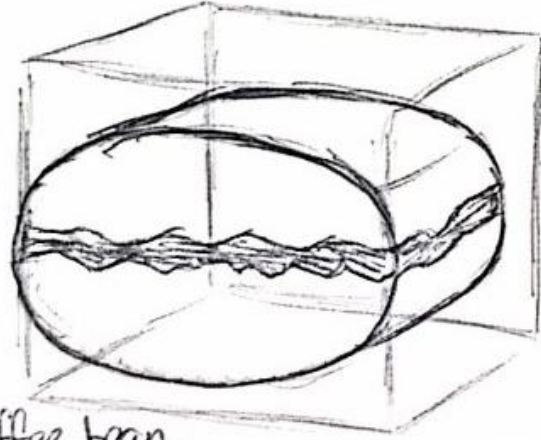

Coffee bean.

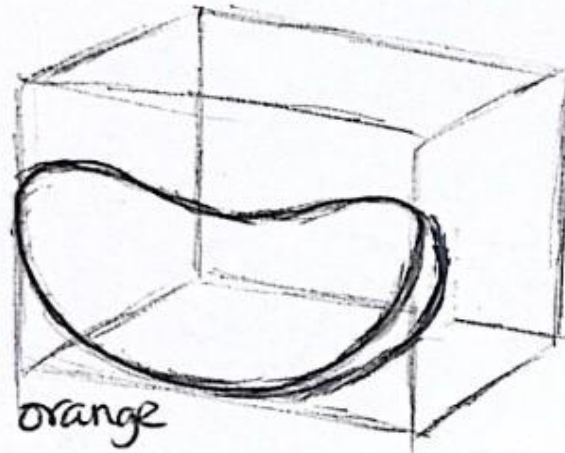

orange

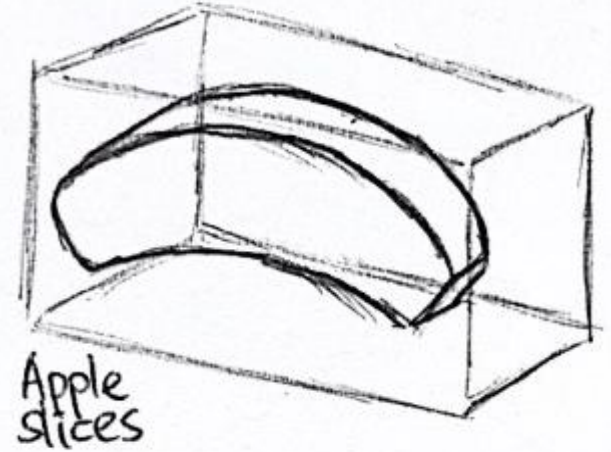

Apple slices

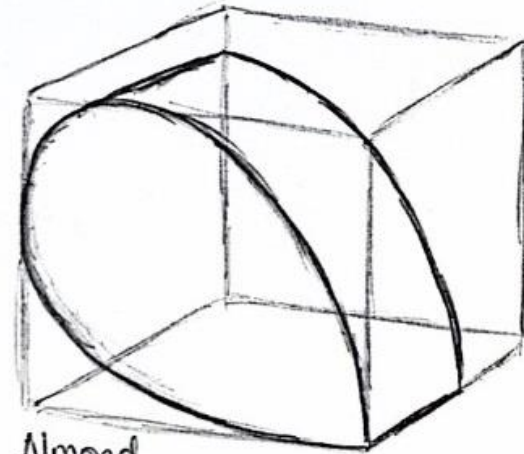

Almond

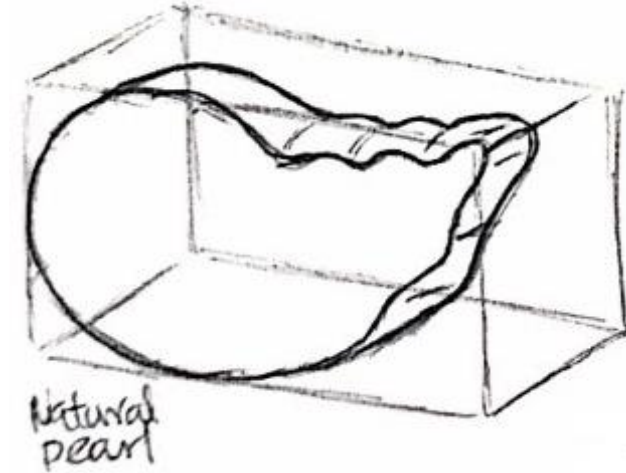

Natural pearl

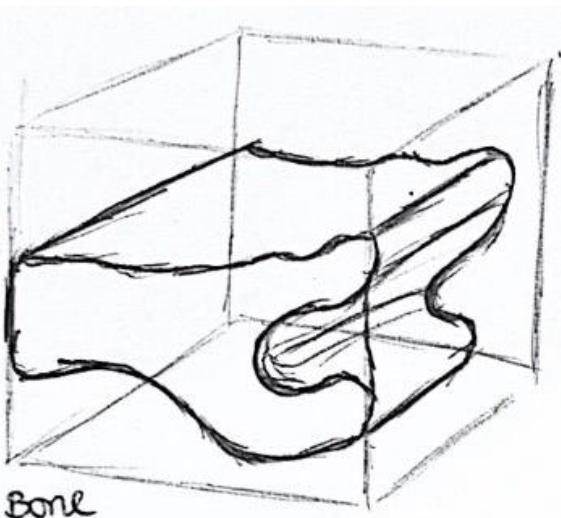

Bone

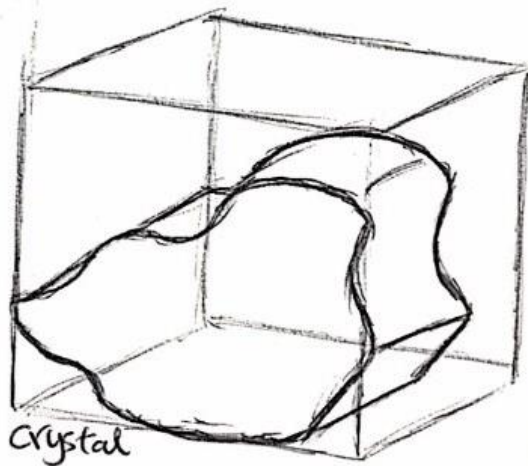

Crystal

During the process, I tried to sketch out all the outline of the natural items into 3D forms. This have given me ideas on the ways to design the desk. Apart from designing the desk surface into the natural shapes, I have started to get an idea that the desk features and components can also be designed in those natural shapes. This can form a combination of different natural shapes in a desk design. For example, the desk's legs can be designed in a bone shape, which is an interesting idea.

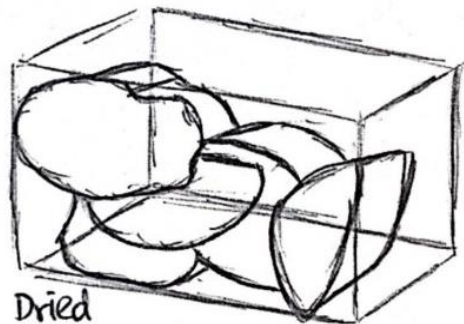

Dried
Banana crisps.

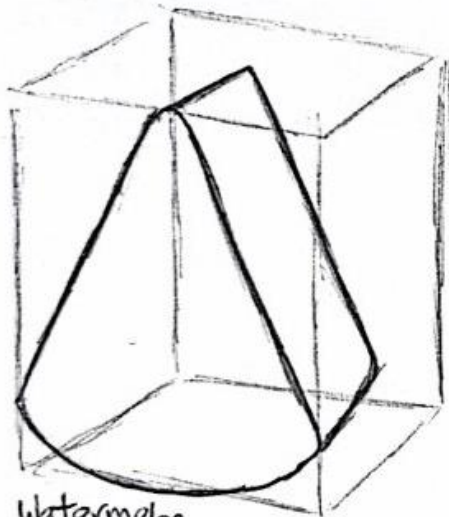

Watermelon
slice

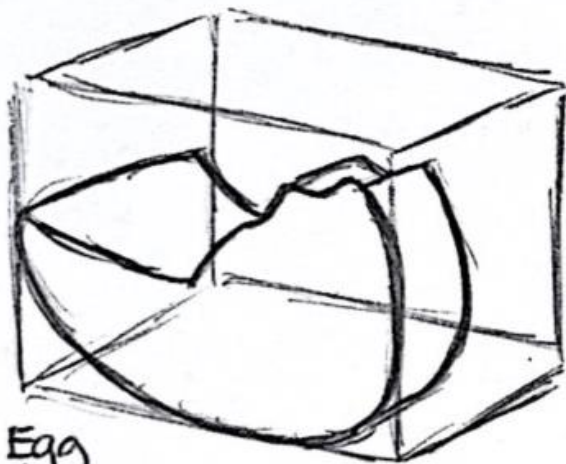

Egg
shell

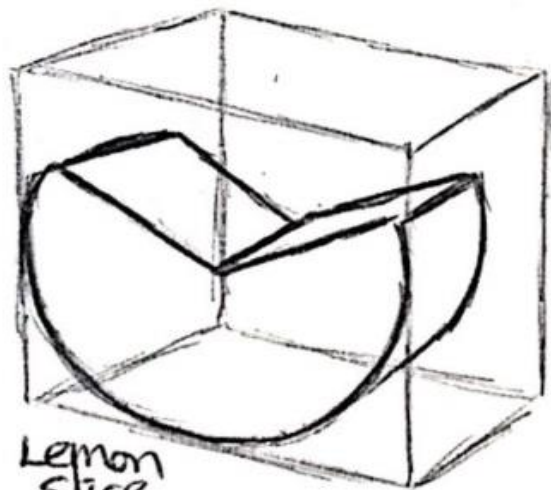

Lemon
slice.

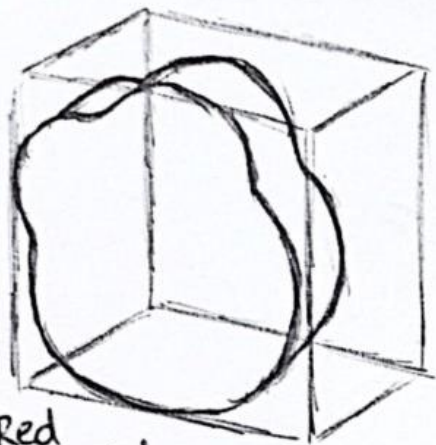

Red
rose petal

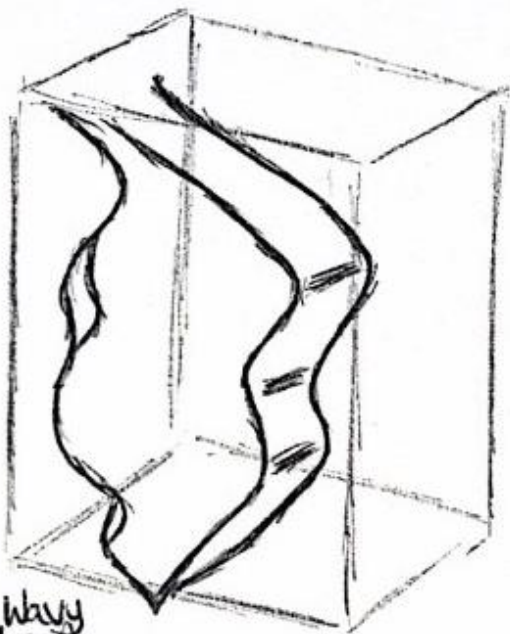

Wavy
Leaf

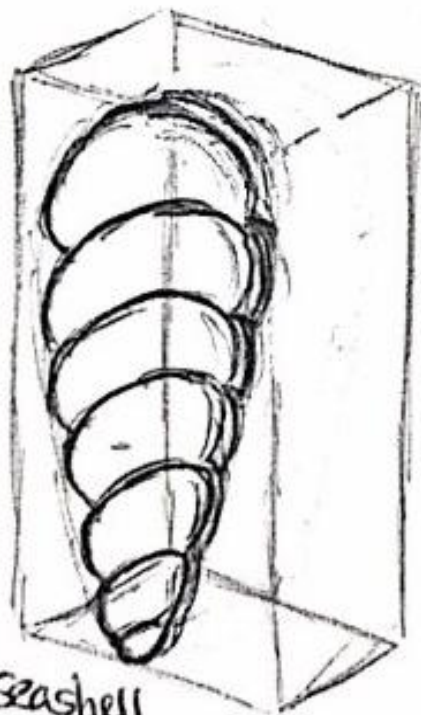

Seashell

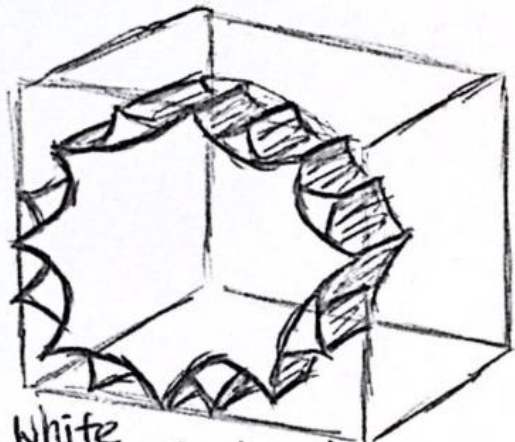

White
rose (outer layer)

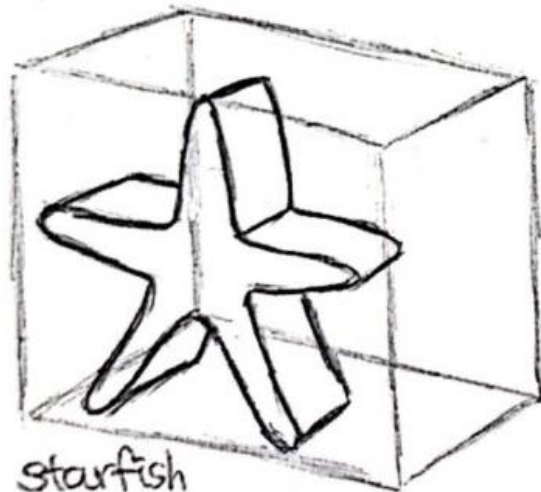

starfish
seashell

Ideation: Developing my ideas through the use of combination of different shapes.

Design 1: Inspired by Watermelon slices & Lemon slices

The desk has been designed through the use of combinations of natural shapes. For example, there are the shapes of watermelon slices and lemon slices being combined together into the shape of a desk surface. The legs are designed in long trapezium shapes. Overall, I feel like this design does not look really natural, and it looks more like a geometric design, therefore I have decided to add some adjustments, such as the legs' shape.

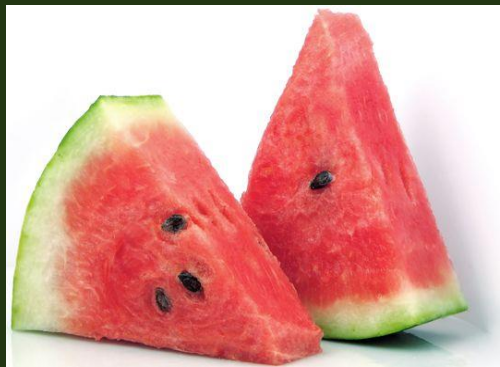

Watermelon photo from Pinterest, as the watermelon had already been eaten when I was about to take photo.

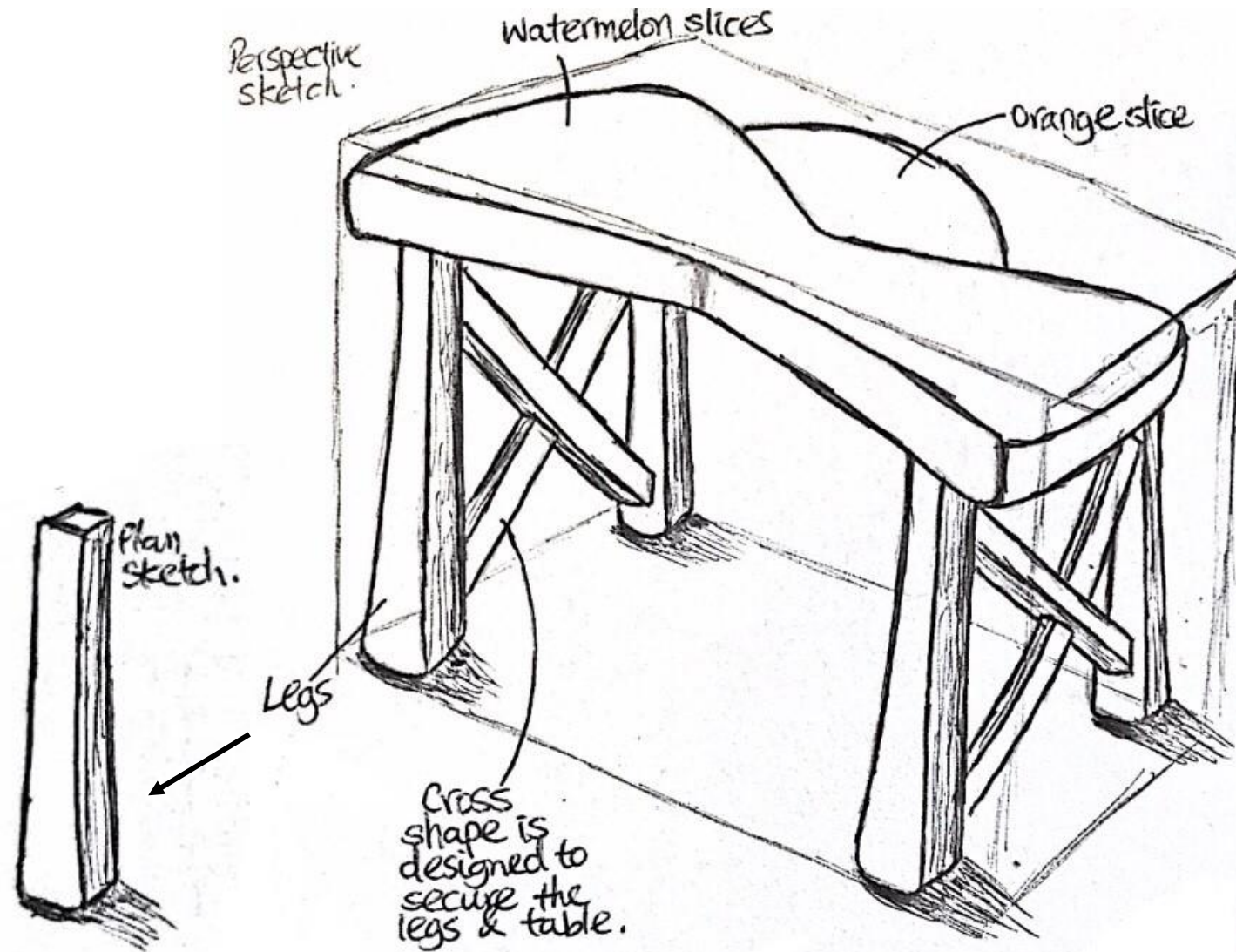

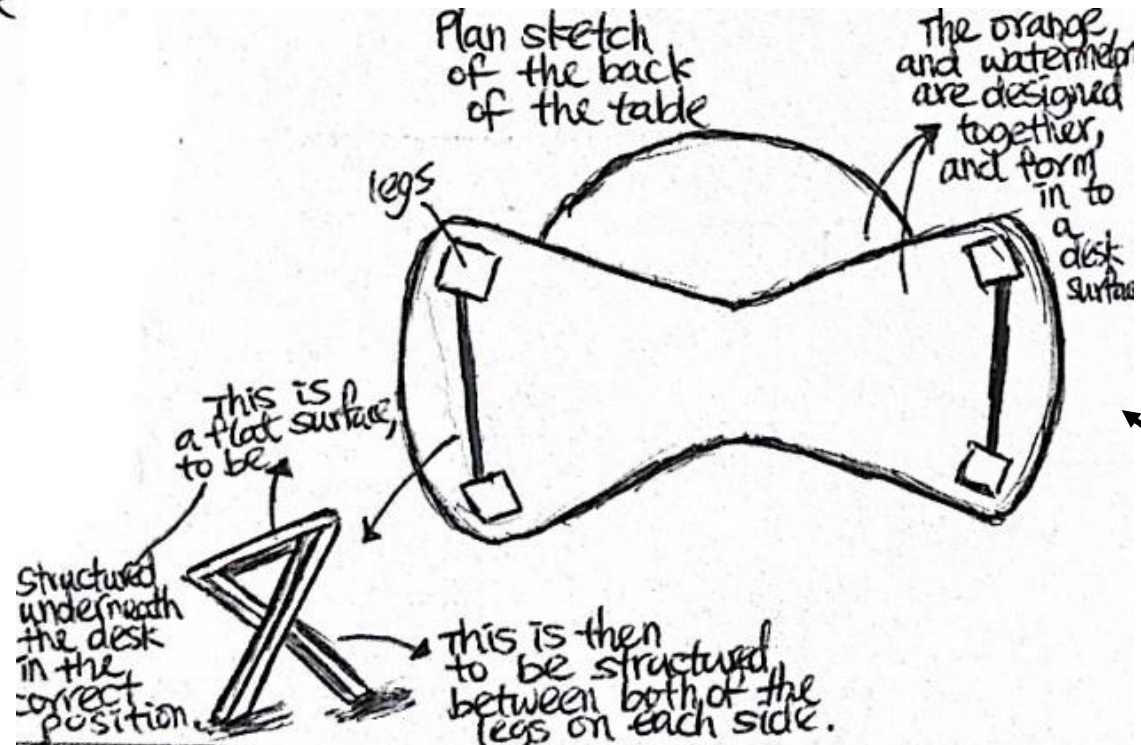
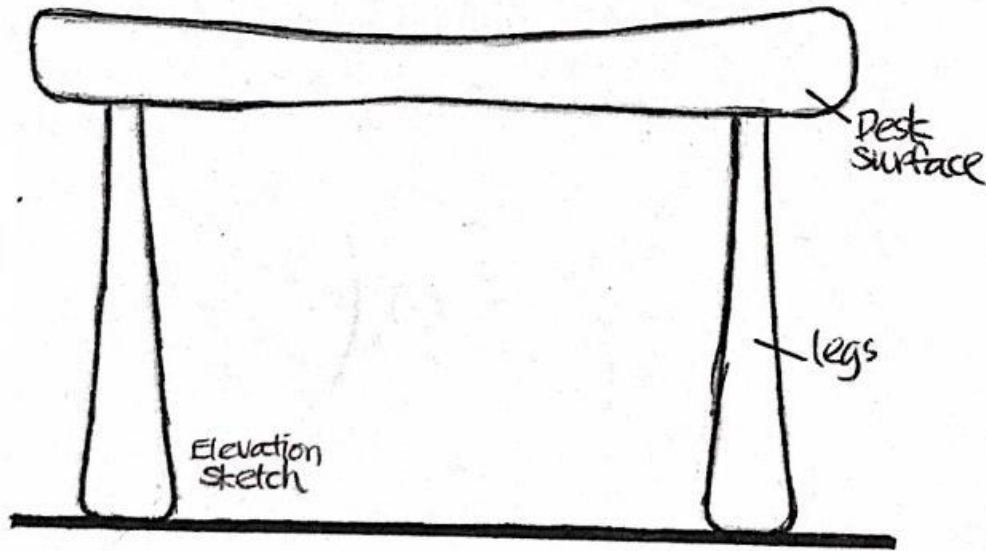
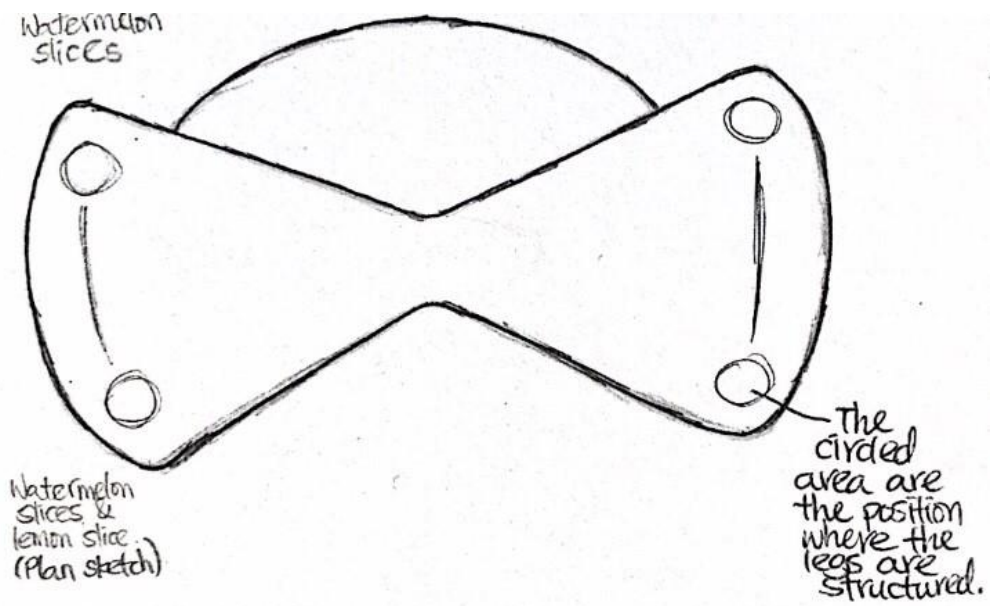
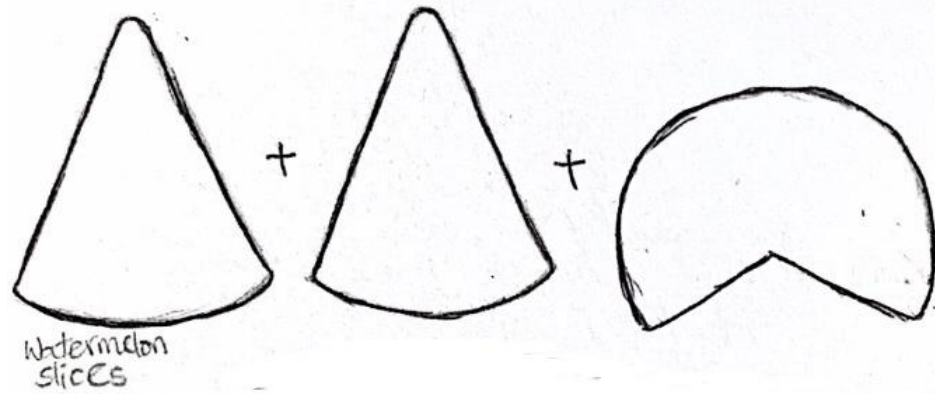

The plan sketch of the layout underneath/below the table. For example, the location of where the legs are structured, and how they are connected.

When I was designing the structures underneath the desk, I tried to think of ways to make the desk more stable to use, rather than only having four medium sized legs. Therefore, I added a cross structure between the front and back legs, which is also structured underneath the desk, to make both legs more stable and secure. I have done this on the right front & back legs and left front & back legs.

Design 2: Inspired by Bones & Wavy Leaf

The natural & organic desk has been designed through the use of combinations of different natural shapes. The desk surface is shaped like a wavy leaf, and the legs are shaped like bones. When I was developing this desk, I tried to find the natural shapes (that I had generated) that can fit well together, and can express some feelings the moment the users look at it. For instance, this desk design can express the forest's atmosphere. The bone's legs reflects the dead species' bones on the muddy ground. The wavy leaf reflects the movement of the leaves falling off the tree.

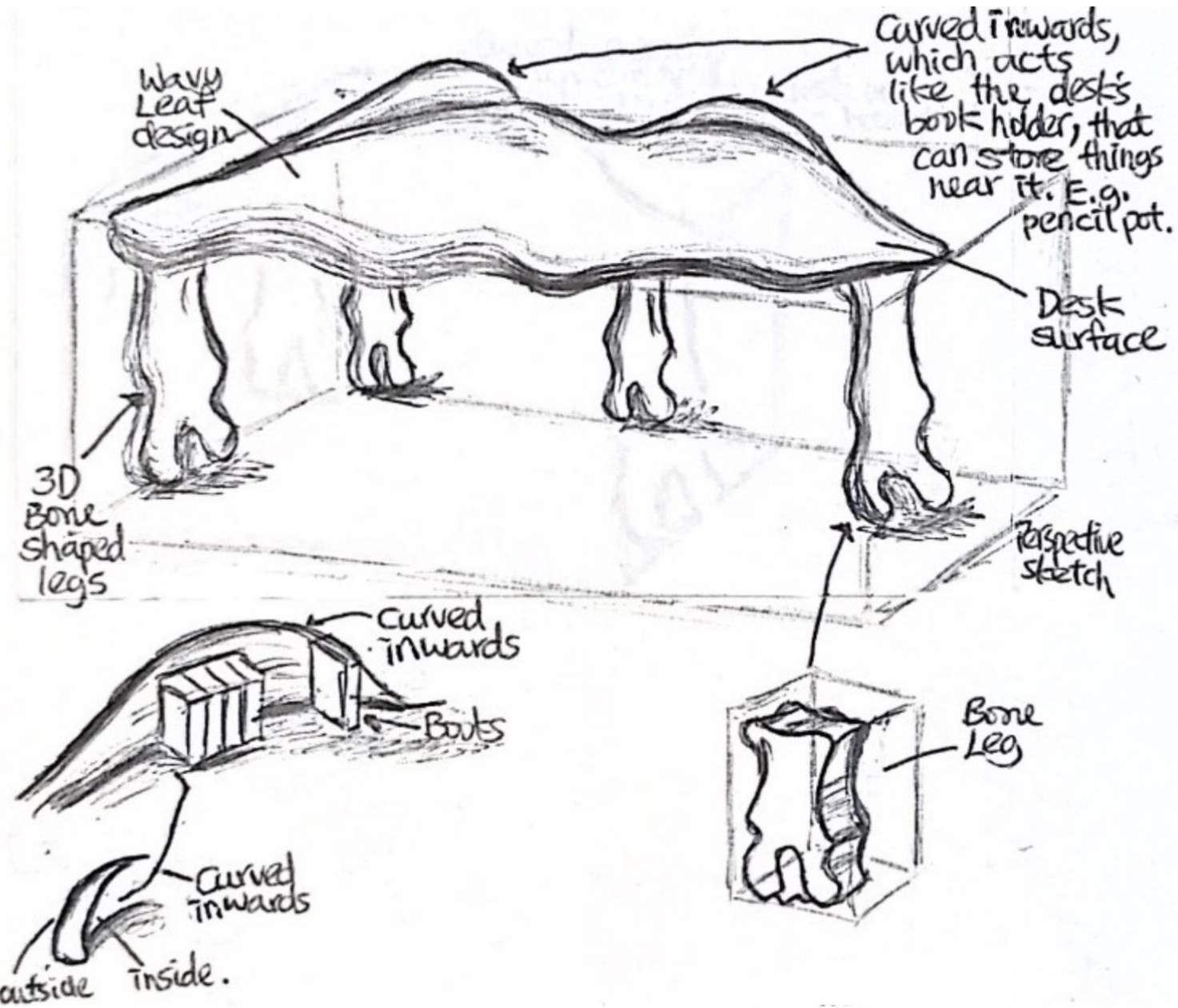

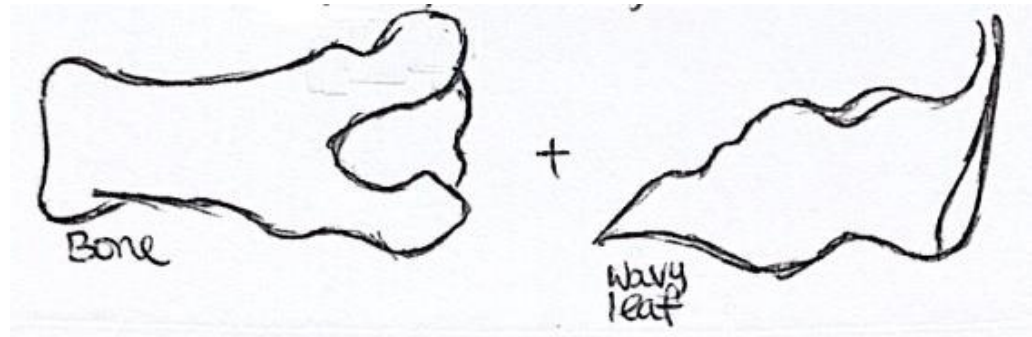
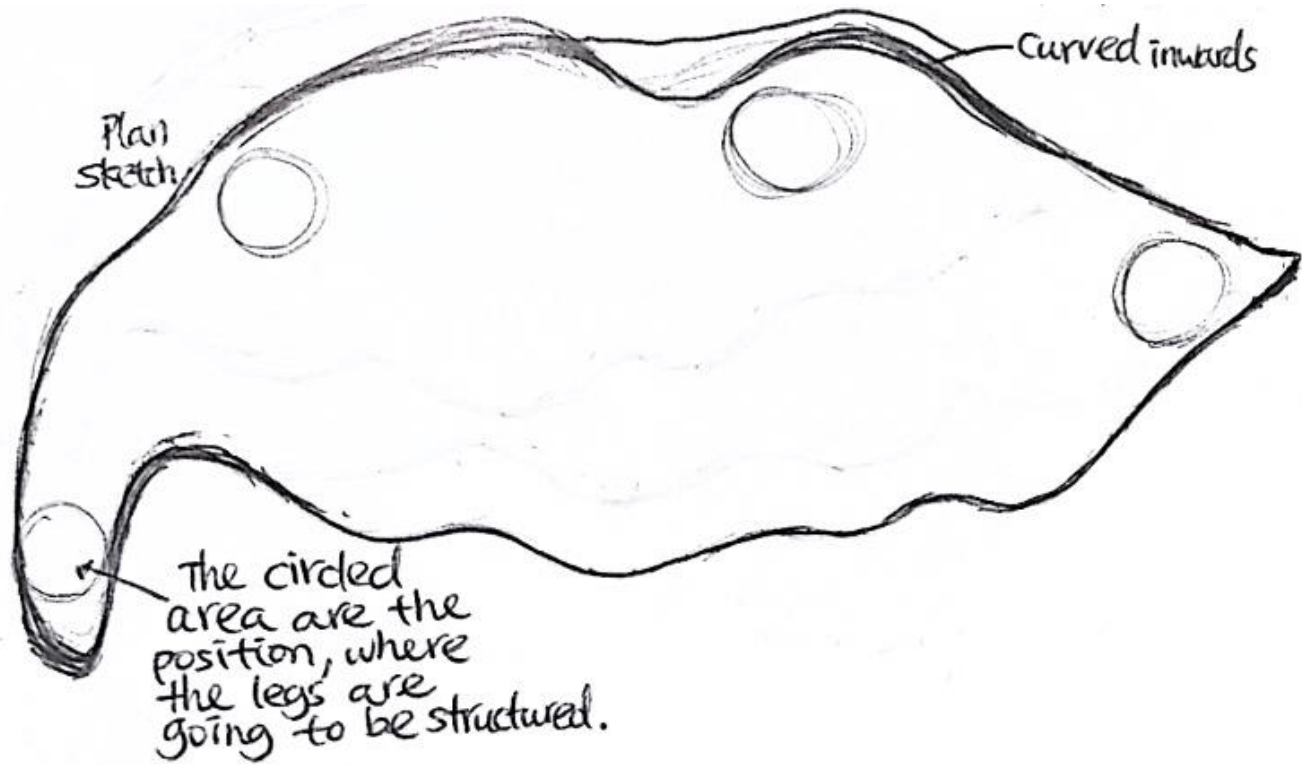

The part that I like in this design is the wavy leaf with some curving parts. I have turned the parts that's curving inwards on the leaf into curved structures that are designed to blend in with the shape of the design. The curved structures curved inwards, over the desk surface, which means books or things can be placed securely on the desk surface in those locations. The reason is that the curved structures have curved inwards, which acts like a protector to prevent things from falling off the desk.

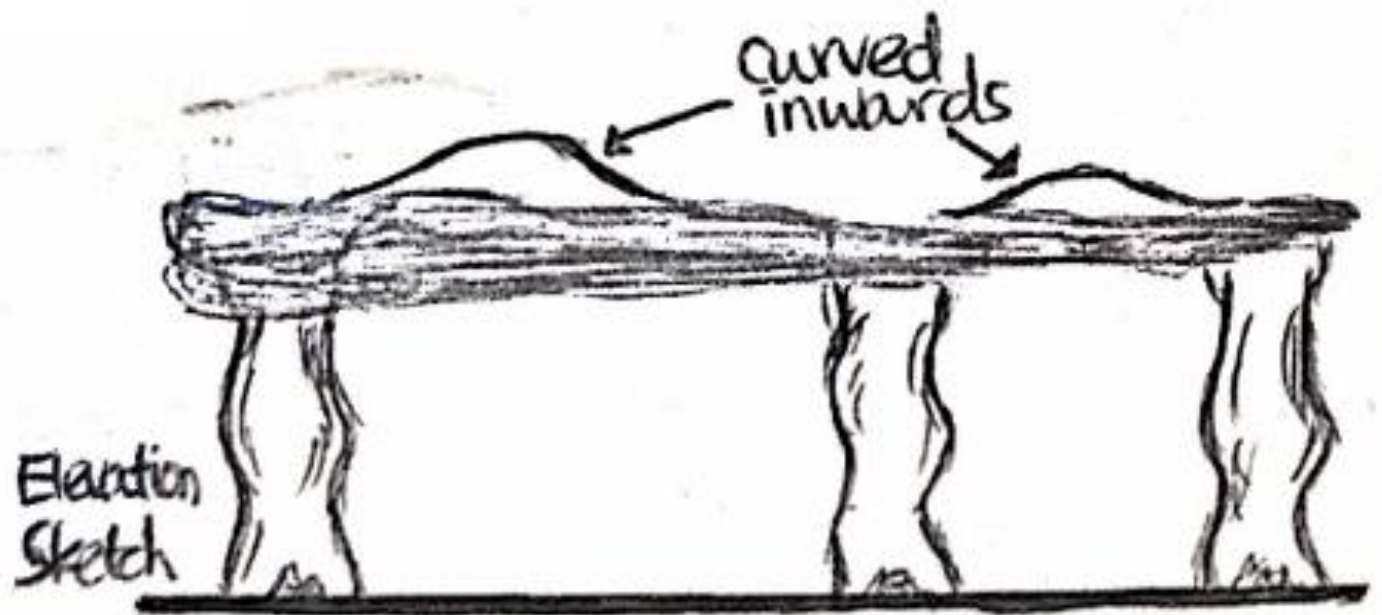

Design 3: Inspired by Seashells, Rose's outer petals & a Rose petal

This natural & organic desk has been designed using combinations of different natural shapes. For instance, the right two legs of the desk are inspired by the shape of the long seashell. On the left, there is only one structure that act as a leg, which is huge and strong. The leg is shaped like a 3D rose petal. When I was designing the shape of the desk surface, I tried to make it shaped like the red rose's outer layer. In the front of the desk, there is a curved surface, that has been inspired by the red rose outer layer, curving inwards at an angle. The curving design acts as a protector to prevent things from falling off the desk surface. Stationeries, books, and organisers can all be paced around the curving parts, as the curved structure acts as a protector to secure objects from falling off the desk.

The parts that I like in this design are the long seashell legs, and the rose's outer layer curving inwards, which look beautiful and natural.

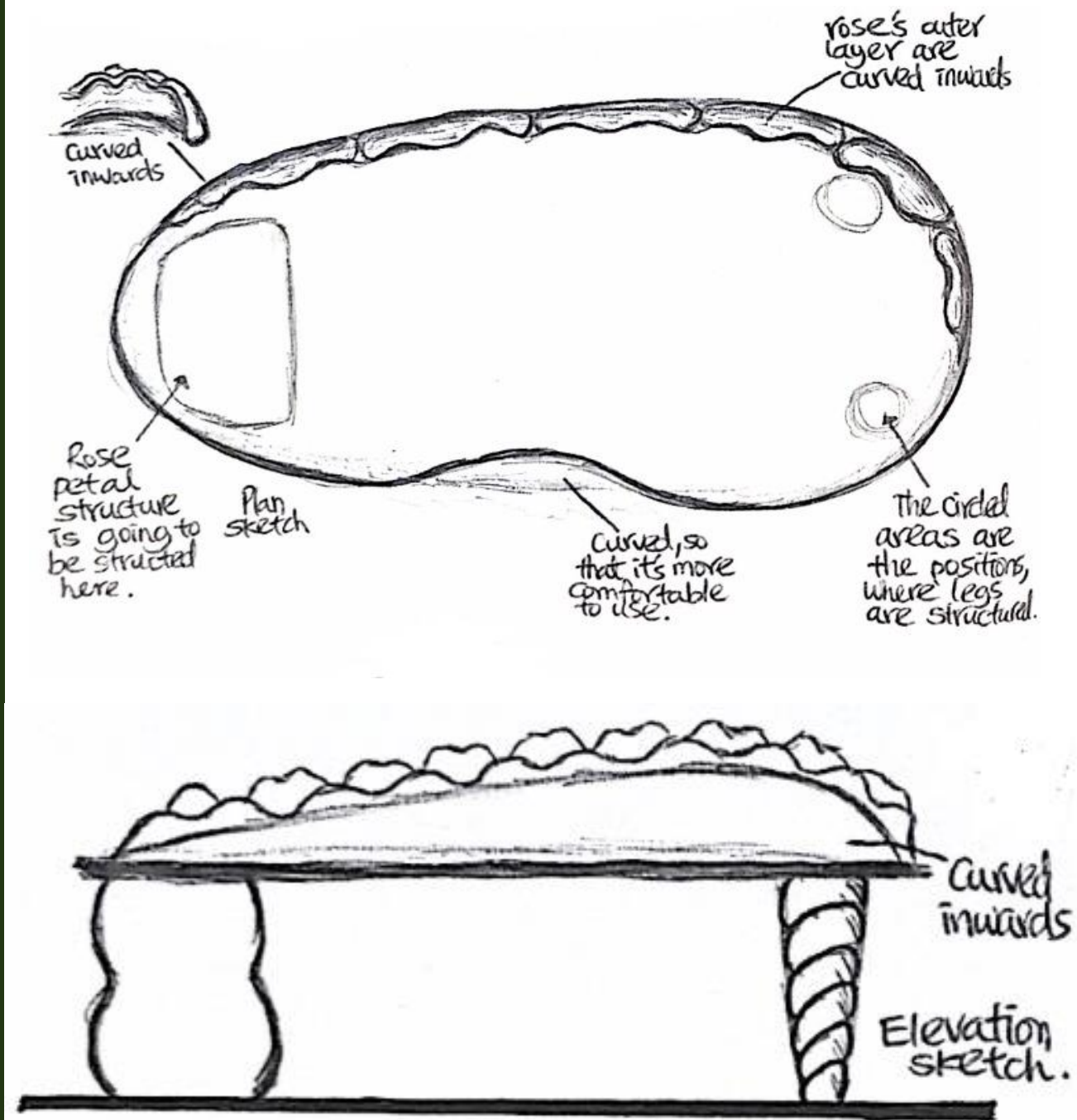

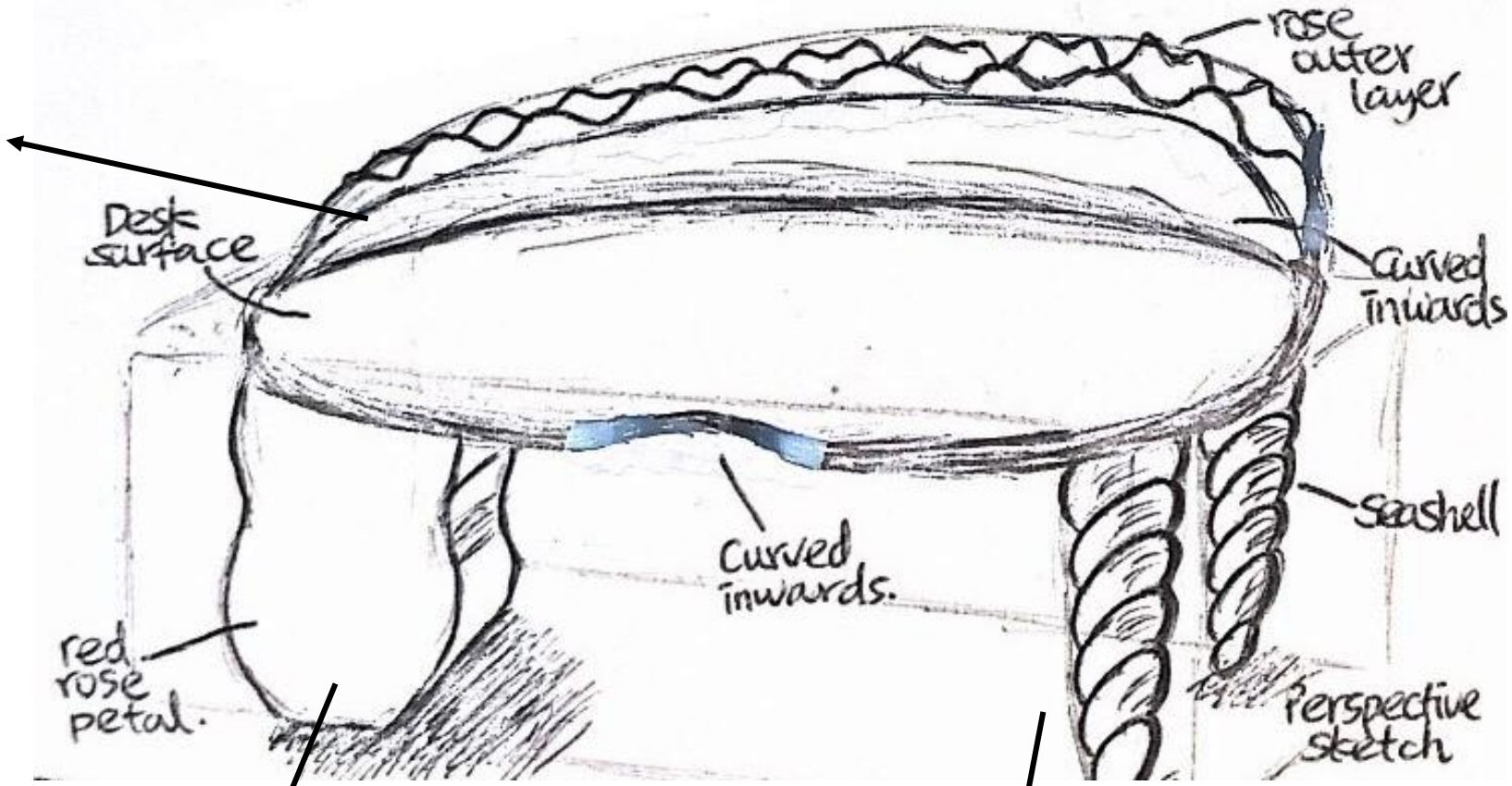
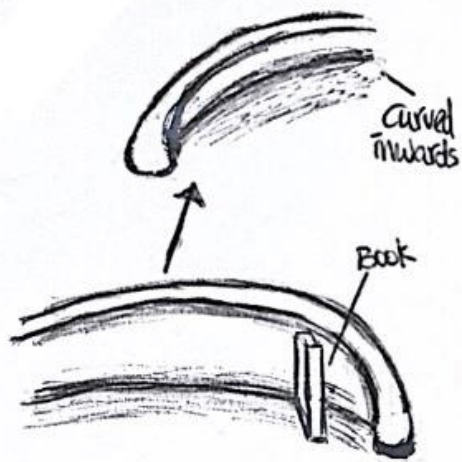

While I was developing this desk design, I tried to find the natural shapes that blend in and can express some feelings the moment the users look at it. For example, all the natural shapes (long seashell, rose outer layer, and a single rose petal) can spread the elegant and natural style of the desk, which can then express the sense of beauty wherever the desk is placed.

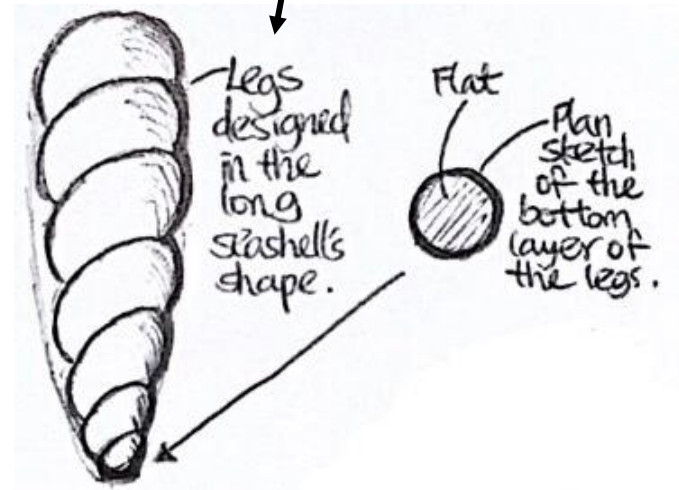
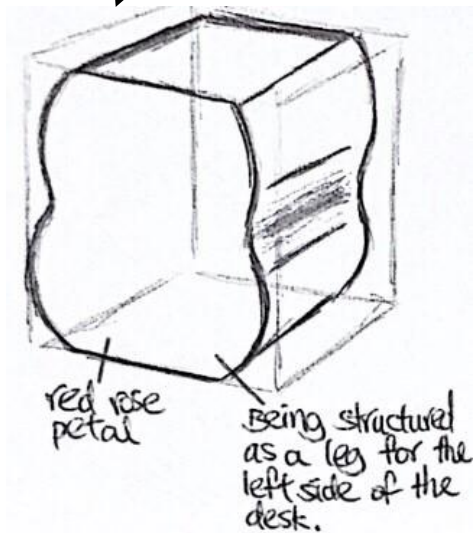
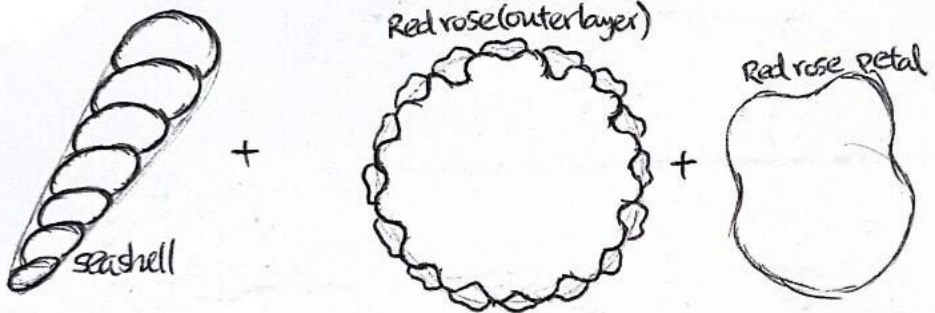

Design 4: Inspired by Orange Segment & Apple Slices

This desk has been designed using combinations of different natural shapes, which are orange segment and apple slices. The desk surface is inspired by the orange segment, and there are legs on both sides of the desk inspired by the apple slices. However, for the legs' design, I have played around with the shapes by increasing the same shape (inspired by apple slices) multiple times and combined them into the form that blends in with the shape of the desk surface.



In the front curved section of the desk, I have designed a 3D thin curved structure that curved from the left side to the right side of the desk, which is designed to make the users feel secure when they are working, rather than letting other people see their legs.

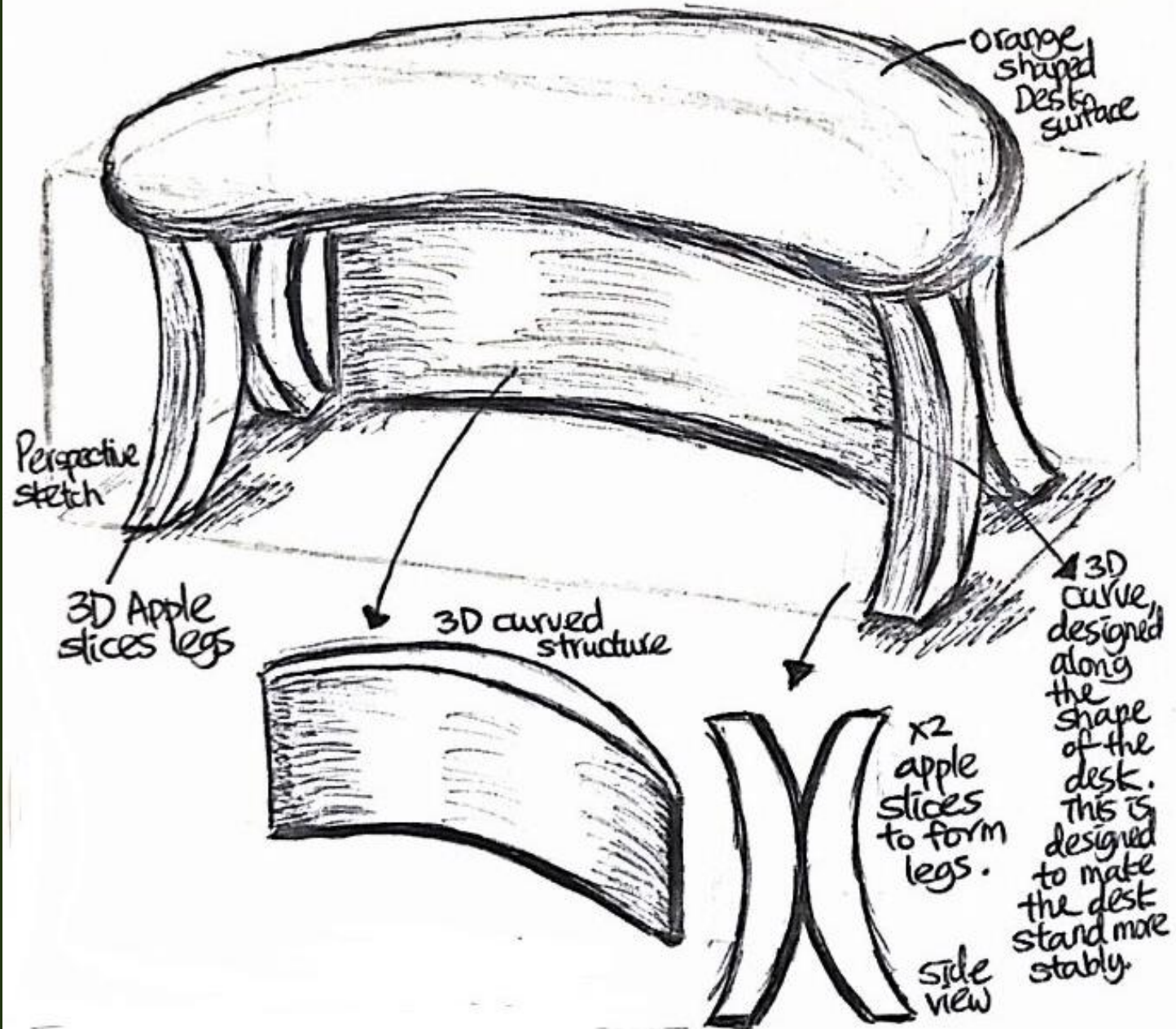
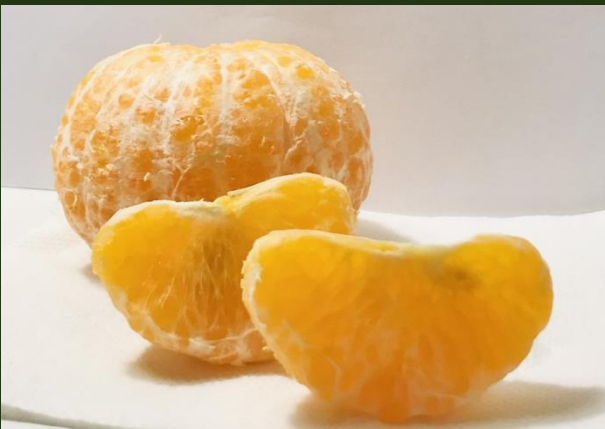

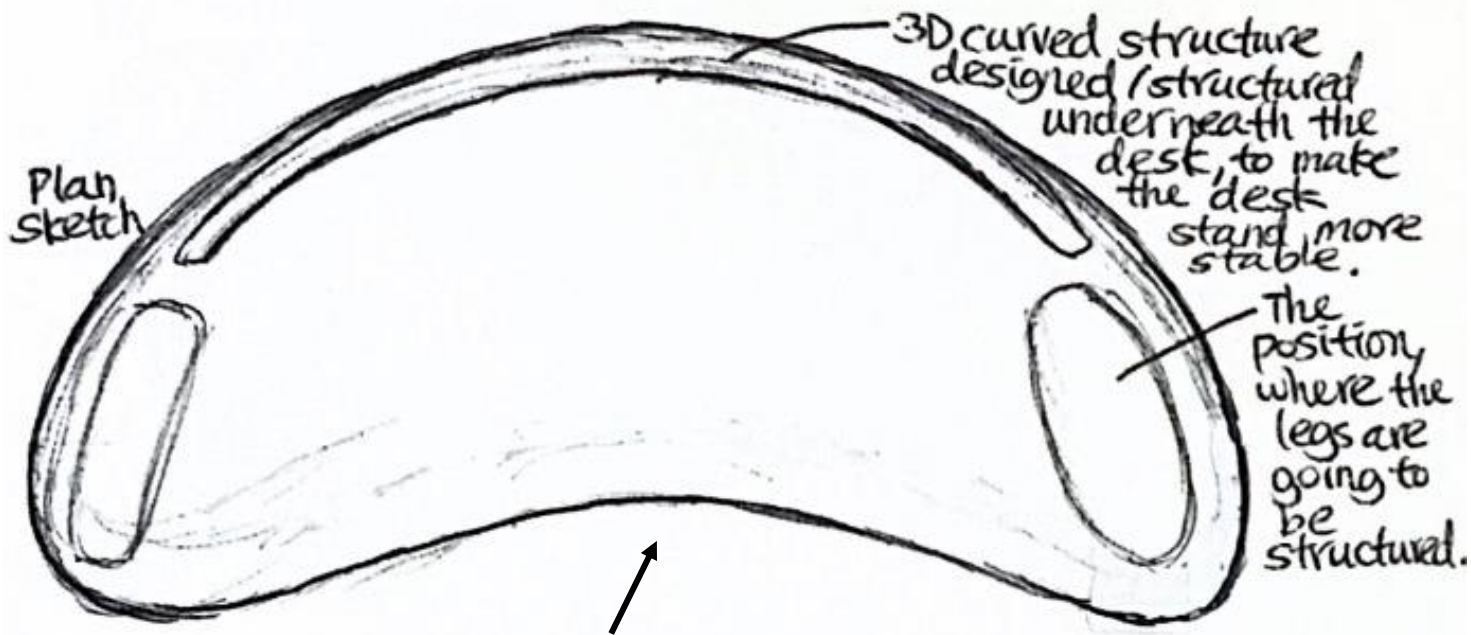

There is a curved outline towards the area where the seat will be placed, so that the user will feel comfortable when working on the desk.

This desk's design looks simple and it looks suitable to be placed in either a simple or complex interior space, but it depends on the situation. For example, if the desk is to be placed in a simple interior space, then the design can brighten the space and make people pay attention to the shape of the design to explore it. Therefore, both the design and the function of the product are important, as they can both have impact on people and the environment in different ways.

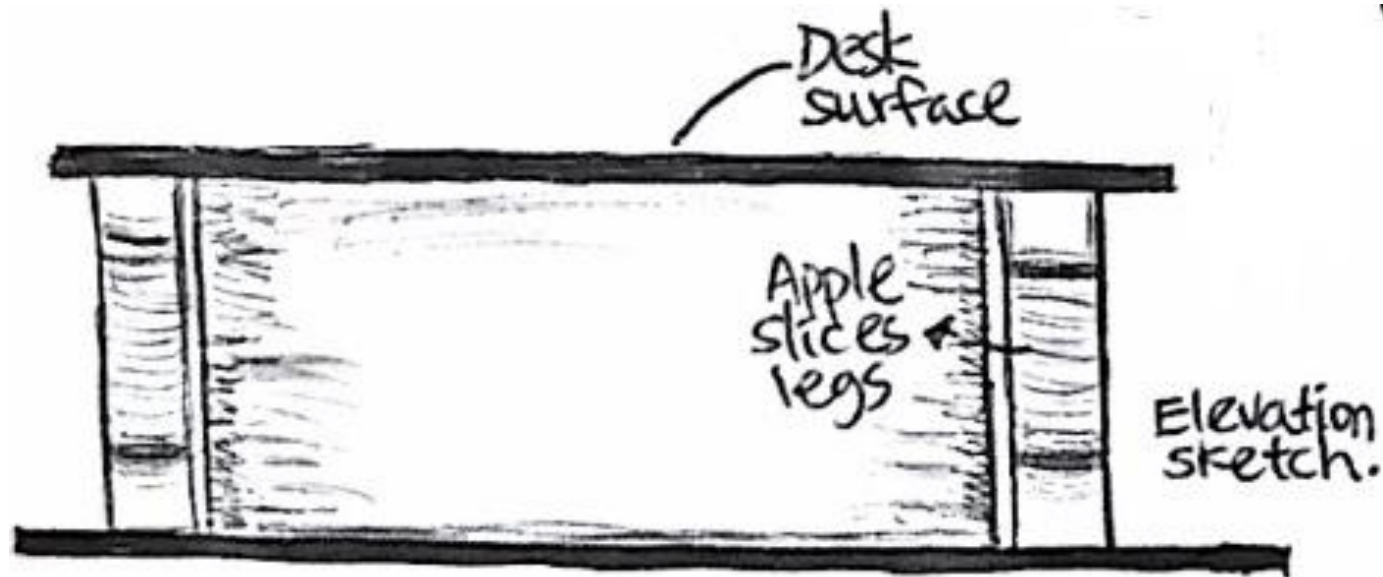
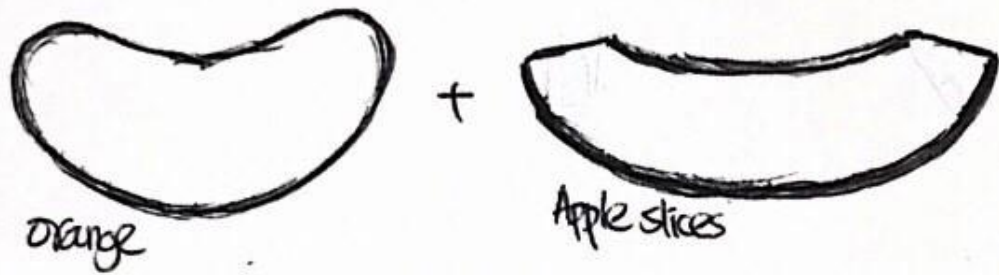

Design 5: Inspired by Apple Slices & Egg Shell & Slotting Techniques' Model

In this desk design, I have combined the slotting model that I have previously made with the shape of the apple slices, and the shape of the eggshell (acts as the desk surface). By reflecting the shapes, I have sketched the shape of the apple slices with the shape of the slotting model, which forms a structure with both shapes included.

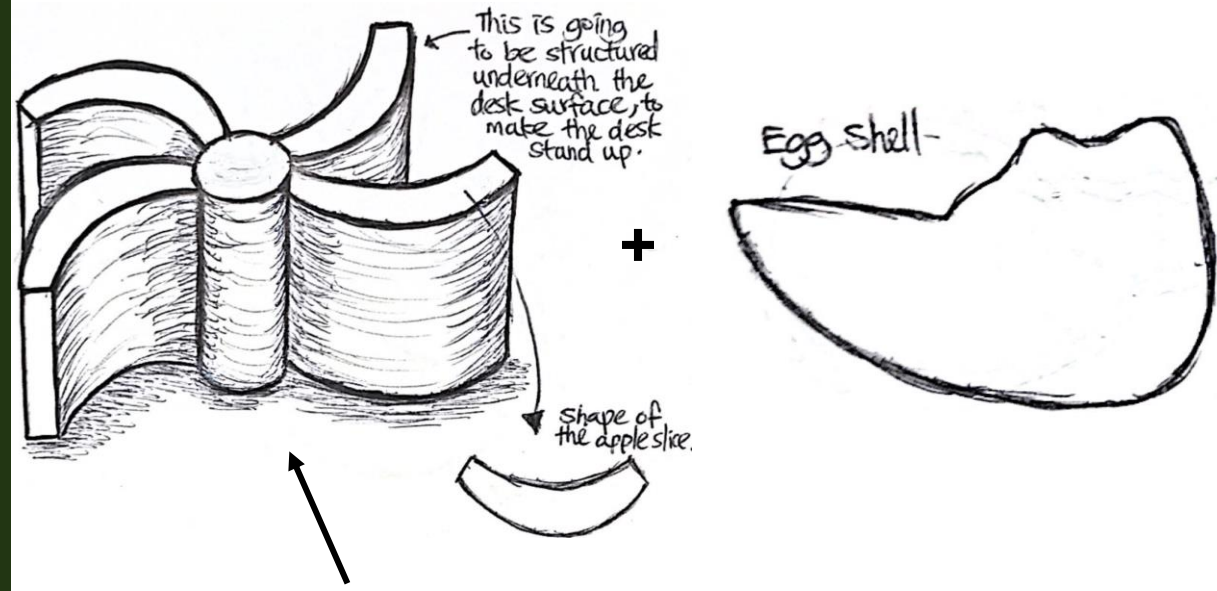
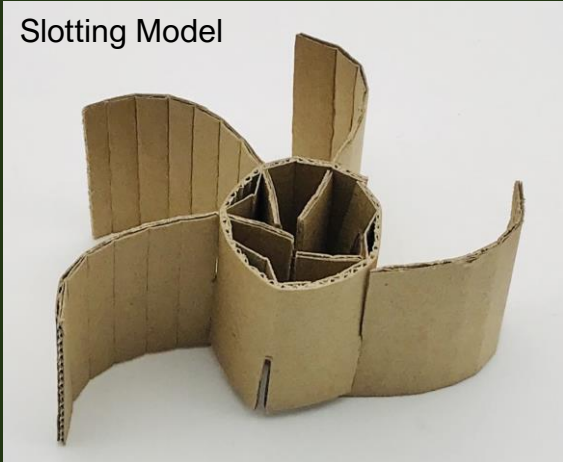

Apple slotting model structure

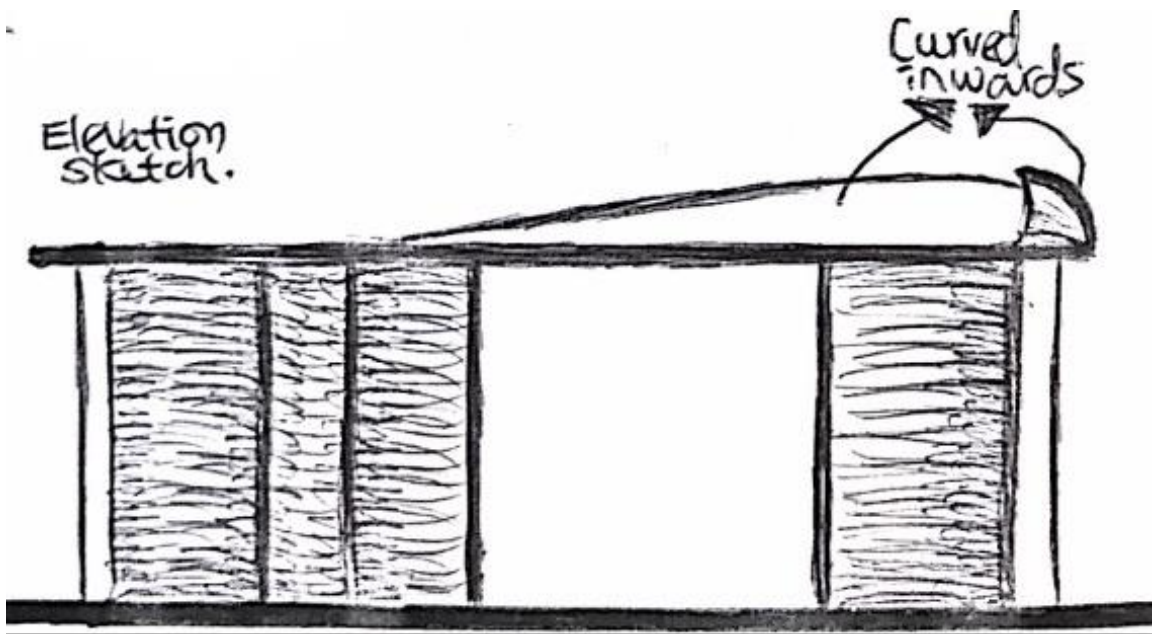

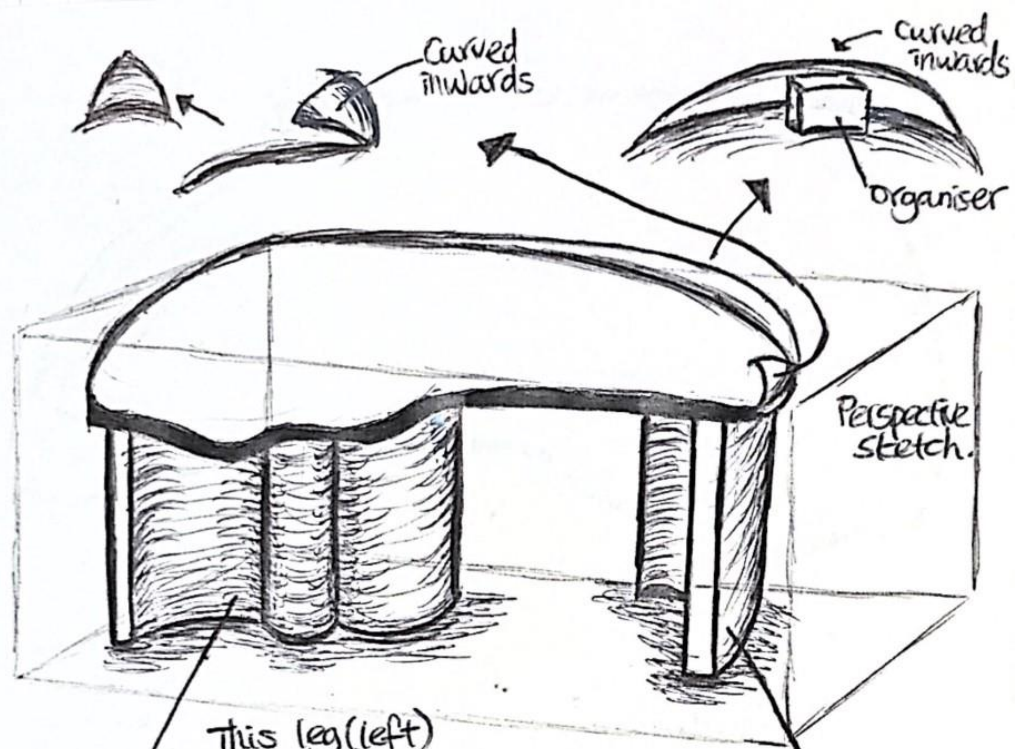

This leg (left) is inspired by the slotting model that I have made.

Apple slice leg.

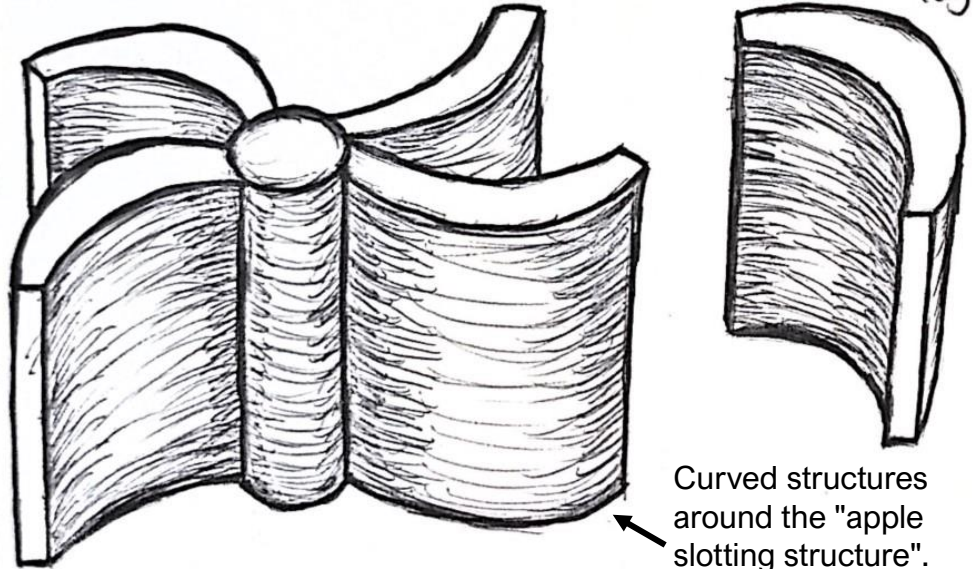

Curved structures around the "apple slotting structure".

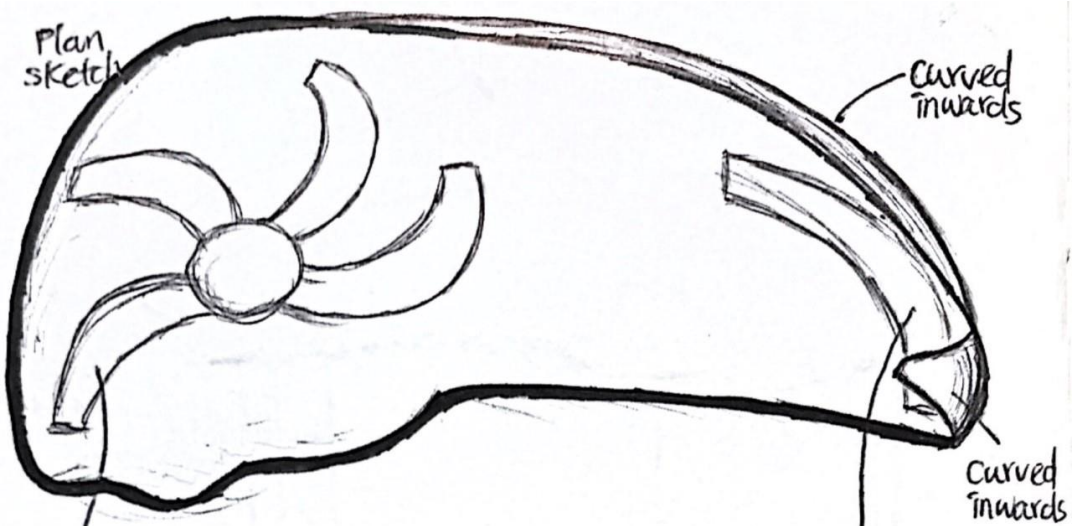

This is the position where the structure will be placed. The structure acts as a desk stand to hold the desk surface & make it stand.

Apple slice leg. This is the position where the leg will be placed.

Later on, I have created a desk, with the shape of the surface inspired by the eggshell. Then, I decided to construct the "apple slotting structure" underneath the desk surface, which acts as a huge leg. The shape of the right leg is also inspired by the shape of the apple slices. The edge of the desk surface is curved, which means books can be stored in that area in a secure way. Overall, the part that I like the most in this design is the "apple slotting structure", which looks unique, and objects can be stored around the gaps of those curved structures.

Models: Prototypes (I have made some models to test and see if the ideas work, and if I need some changes.)

Apply Slotting Technique to Desk Design 1

In this model, I have simply used 3 different materials to make the desk design. The materials are, cardboard, white foamboard, and white straw. I have used my knowledge on the slotting techniques to join the components together into a desk, without the use of any glue or tape. The slotting techniques that I have used are square tab slots, thin tab slot, and circular tab slots.

After I have experienced making this model, I started to understand how to make a much more difficult furniture design using slotting techniques.

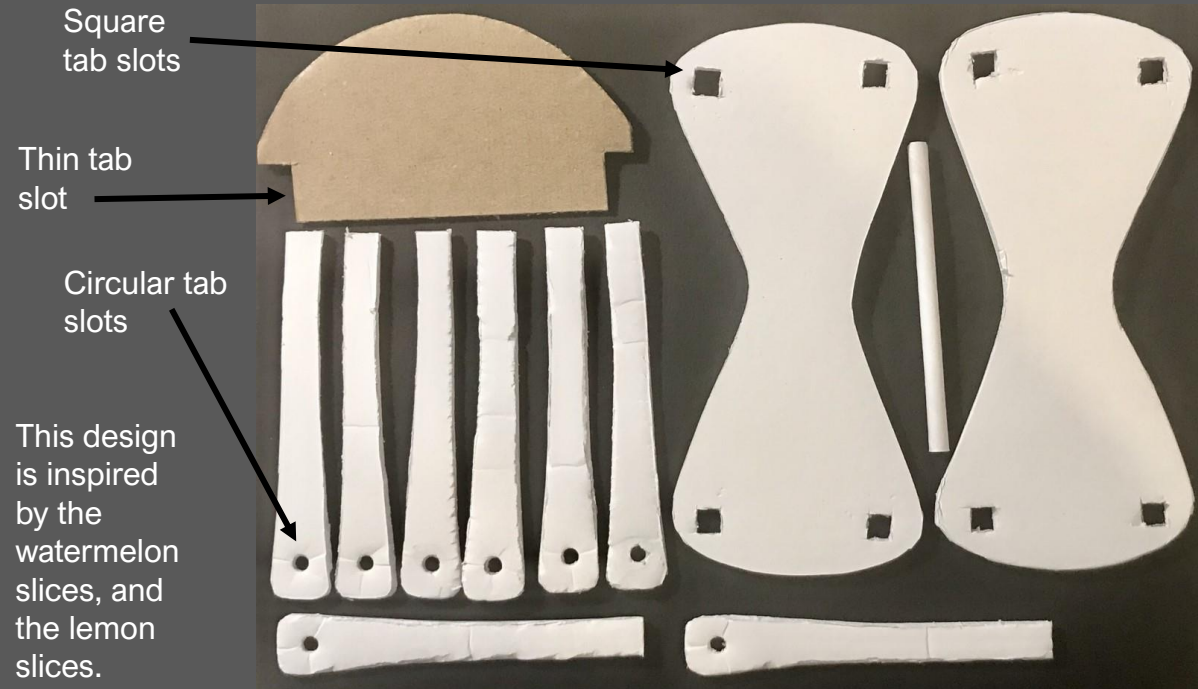

Apply Slotting Technique to Desk Design 2

This desk design is inspired by the shape of a wavy leaf and bones. The model has been made through the use of simple materials, which includes, grey card, thin wires, and thick wires. In this model, I have used my knowledge on the slotting technique to construct the model. The slotting techniques includes circular tab slots, and using thin wires to combine thick wires together. Making this model makes me understand that the way of applying slotting technique to curved and flat surface is the same.

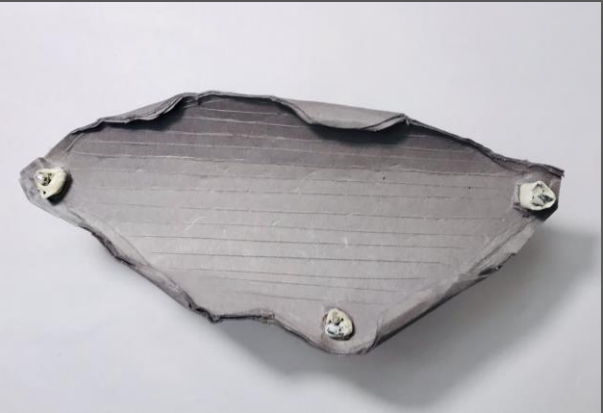

Circular tab slots

Using thin wires to combine thick pieces of wires together.

Secondary Research: Wood Joinery

Wood joinery is a construction technique that involves joining pieces of woods together, to form a strong bond, that can last for a long time without the pieces falling off. The wood joints can be formed between the edges or between the face of the wood, in the direction of the length, at right angles or at different angles. Various glues or fasteners (e.g., nails, screws, bolts) are being used to increase the strength, effectiveness, and rigidity of the wood joints. Since the main purpose of the wood joints is to join wooden parts together, their construction should be done carefully, so it would not weaken the parts that are joining.

In addition, there are different types of wood joints used in different types of construction for different purposes, which suggests that the type of wood joints used in a construction project need to be consider precisely to see if they work together of not.

Types of Wood Joints:

- Dowel joints
- Mortise & Tenon joints
- Biscuit joints
- Tongue & Groove joints
- Rabbet joints
- Box joints
- Basic butt joints
- Half-lap joints
- Through Dovetail joints
- Sliding Dovetail joints
- Mitre joints
- Scarf joints

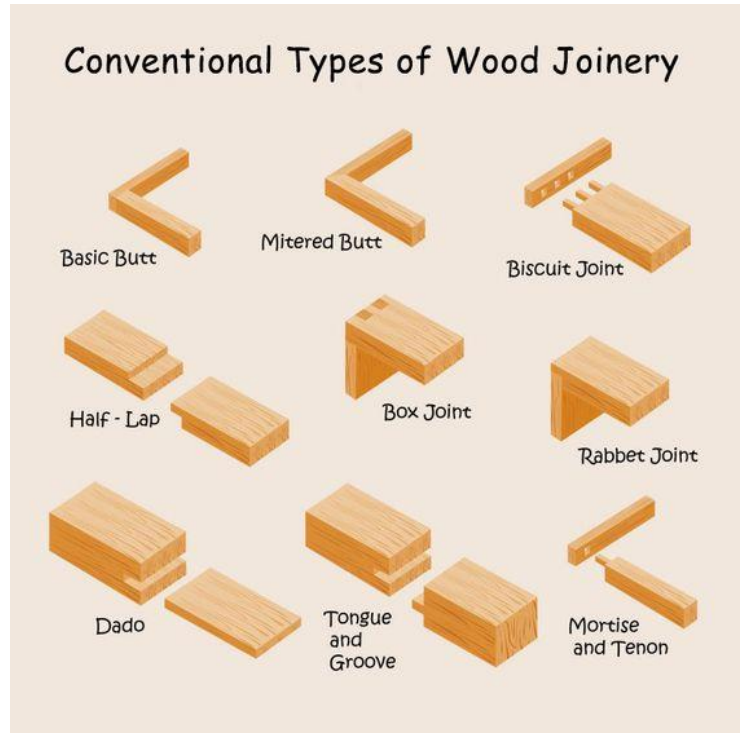
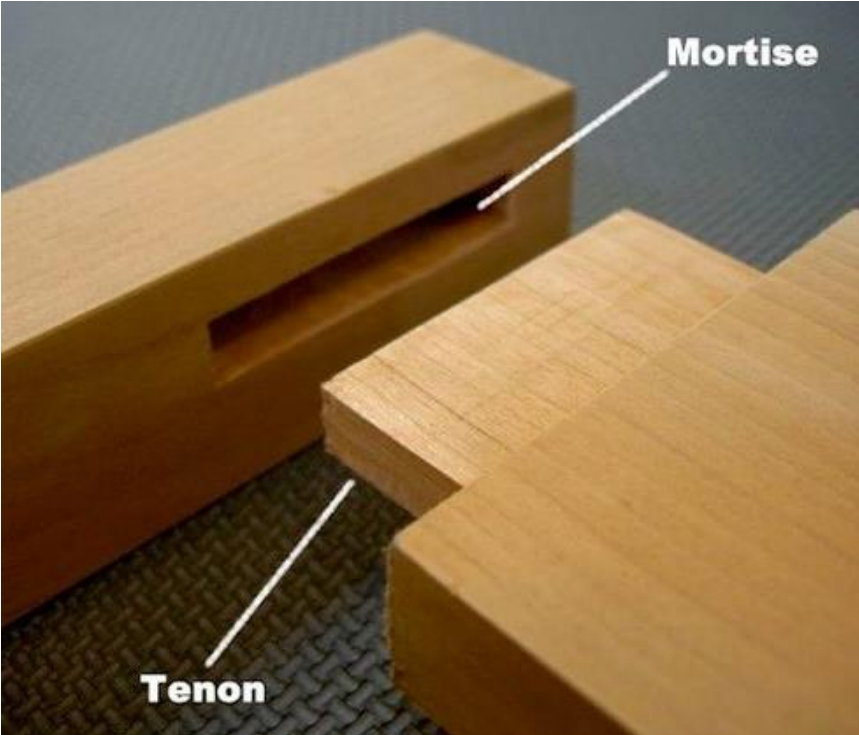



**Secondary
Research: Examples of
Wood Joinery**

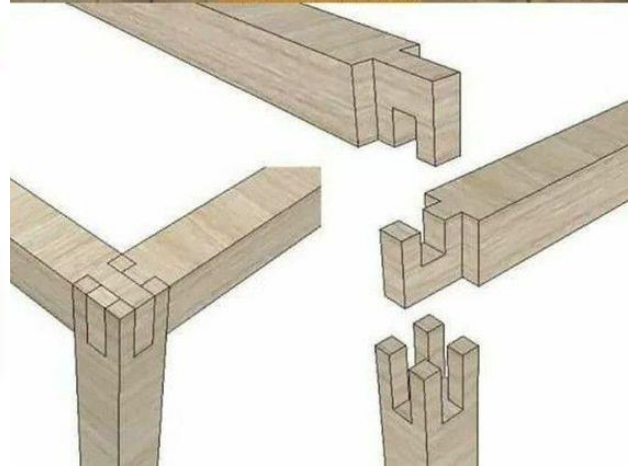
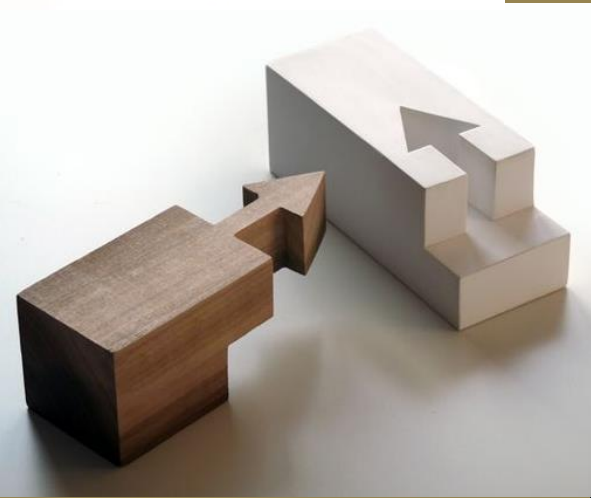

Record: Modelling Desk Design 5 using the 2D Software & Laser Cutter

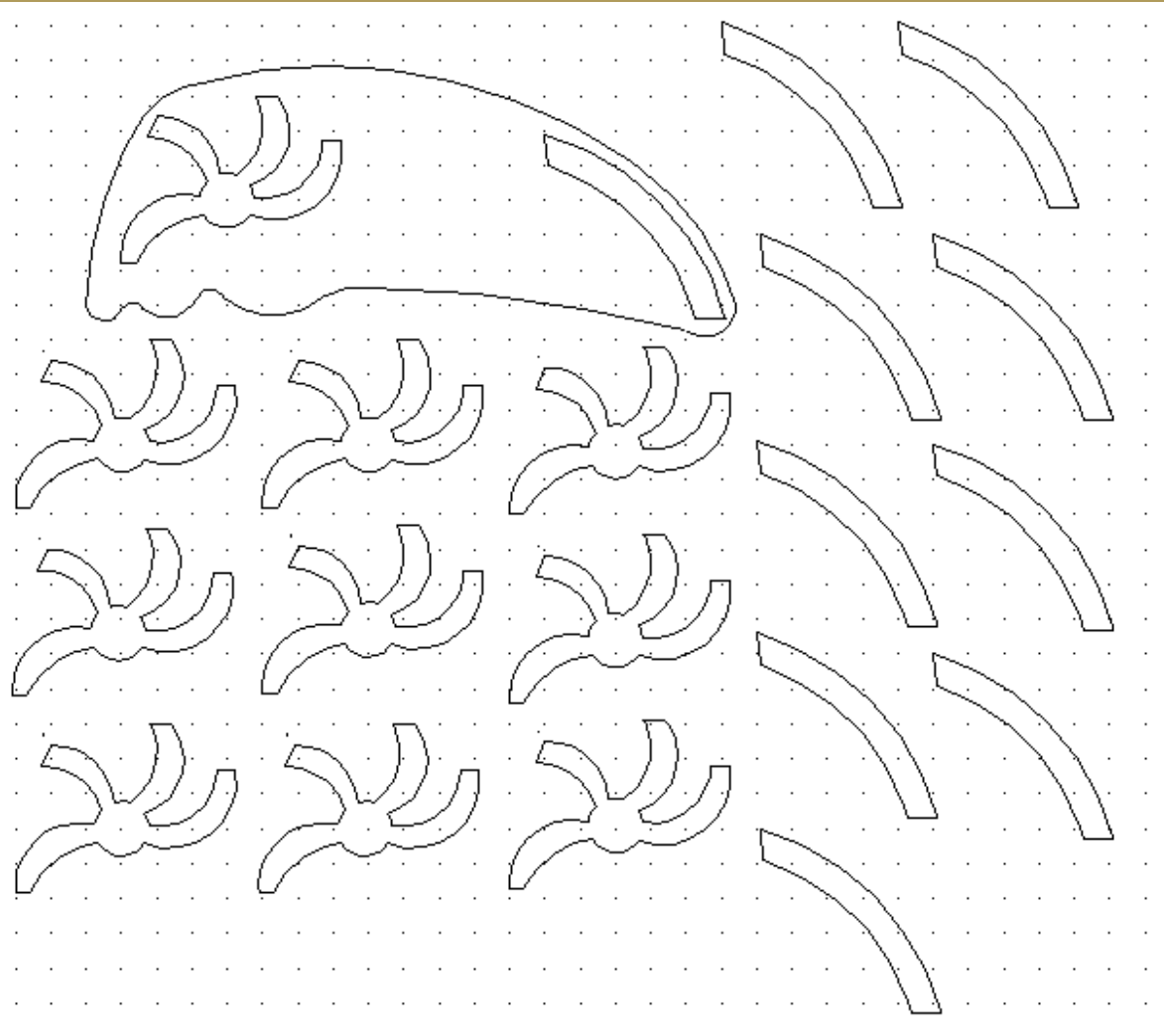

Here, I have created the net of the desk design 5 using the 2D Software, and then I laser cut the design onto the MDF wood. On the 2D Software, I have created the shape of the desk surface, and another two different shapes, which are going to be layered into the desk's long legs. In this design, I have created wood joints, which I will use to join all the pieces, including the desk surface and the legs, together into the desk design.

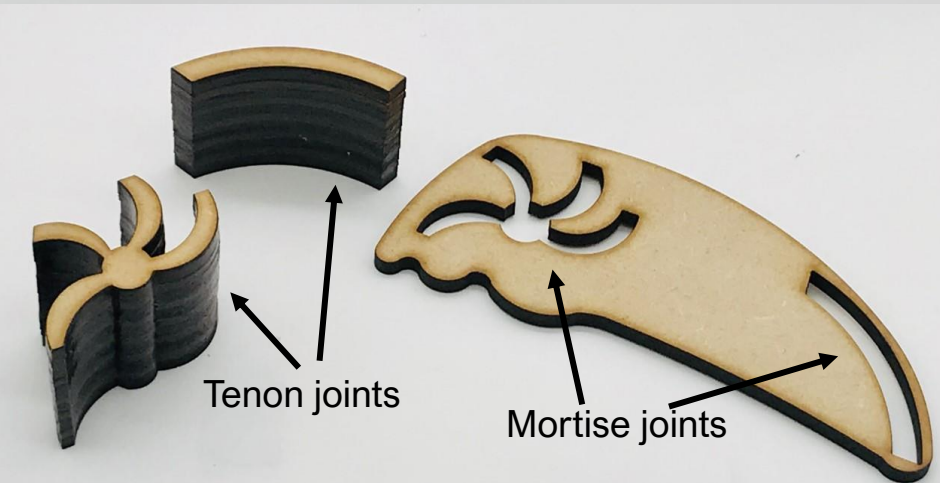
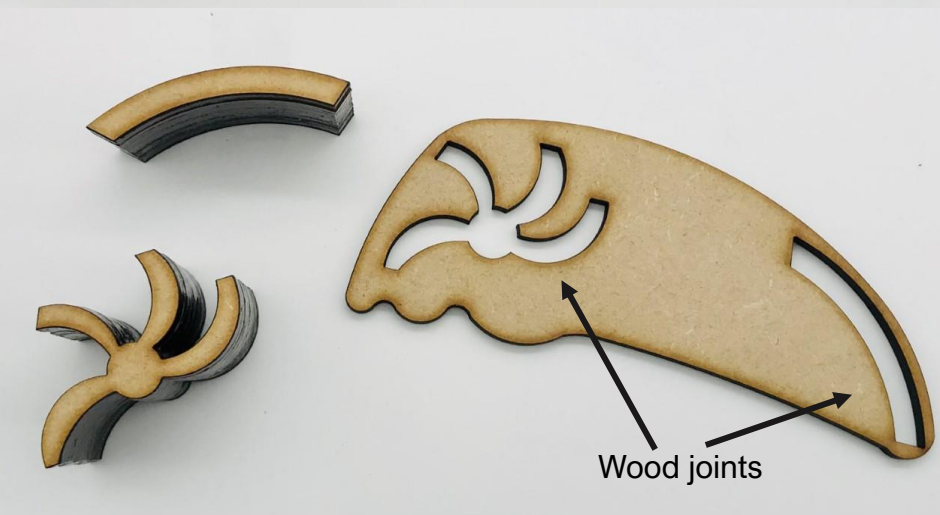

Prototype: Construct the components together into Desk Design 5



Spherical curve which reflects the shape of curved leaves.

I have constructed all the MDF wood pieces together, and then I started to decorate the design in more detailed. For instance, firstly, I used card to test out making the spherical curved designed on the front part of the desk surface to see if the model works well. And then, later I will use a better material to make the spherical curve.

Making this model has taught me the ways of using MDF wood to make models. For instance, I have learnt using thin pieces of MDF wood to make the thick long legs, by layering up the pieces of the same shape.



Model Development of Desk Design 5

In this model, I have used 2 materials, which are veneer wood and MDF wood. Veneer wood has been used to create the curved and wavy structure attached to the front of the desk's surface, which acts as a protector to prevent things from falling off the desk. The structure is also designed to make the user feel the sense of secureness when working, and feeling like being protected, which act like a shield. The entire desk is made of MDF wood, using some techniques, like wood joints and layering.

Curved & wavy structure, which reflects the shape of curved leaves.

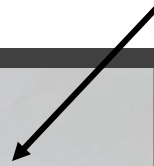

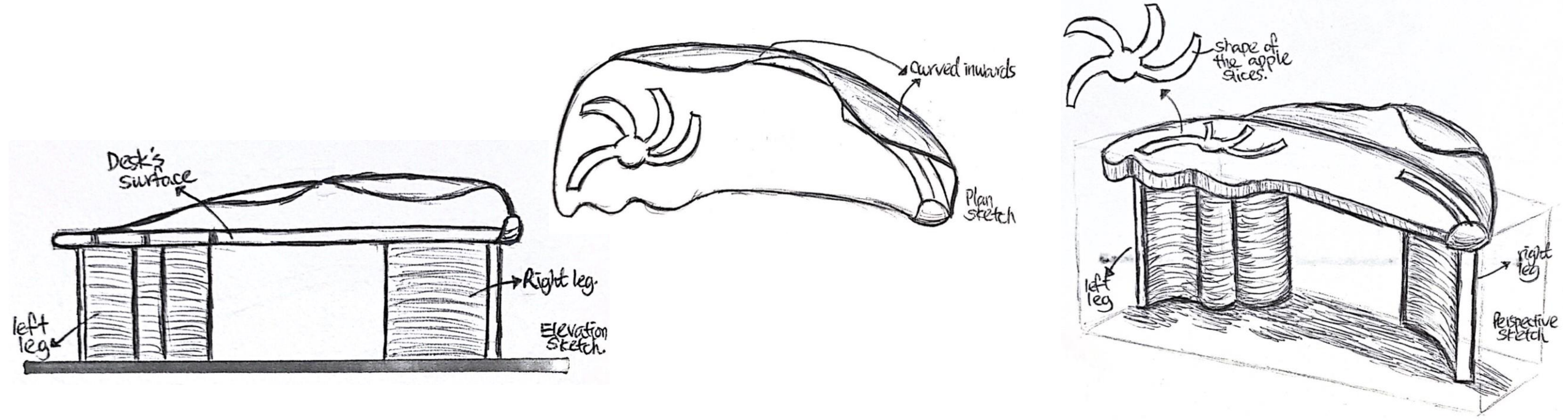

Here, I have used the collage technique to show a person using the desk design, and to roughly show the scale of the design.



Development: Designing the Desk features

(e.g., drawers, cupboards, book stand, storage areas, etc.)

Development Desk Features for Desk Design 1

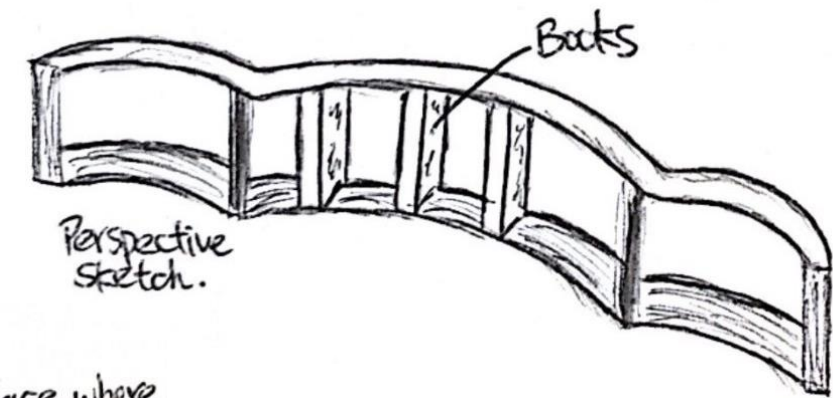

In this desk design, I have created two thick strong legs on both sides of the desk to make the desk stable for people to use.

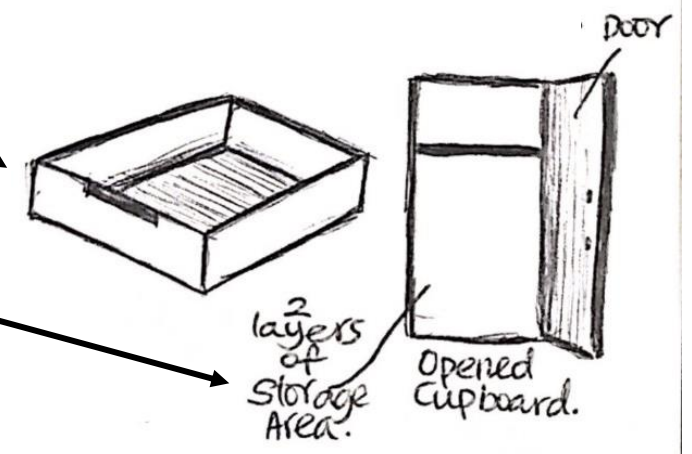
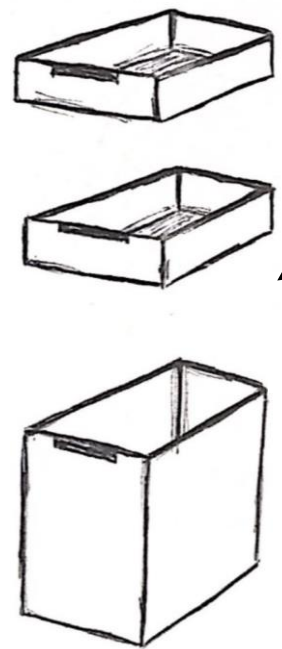
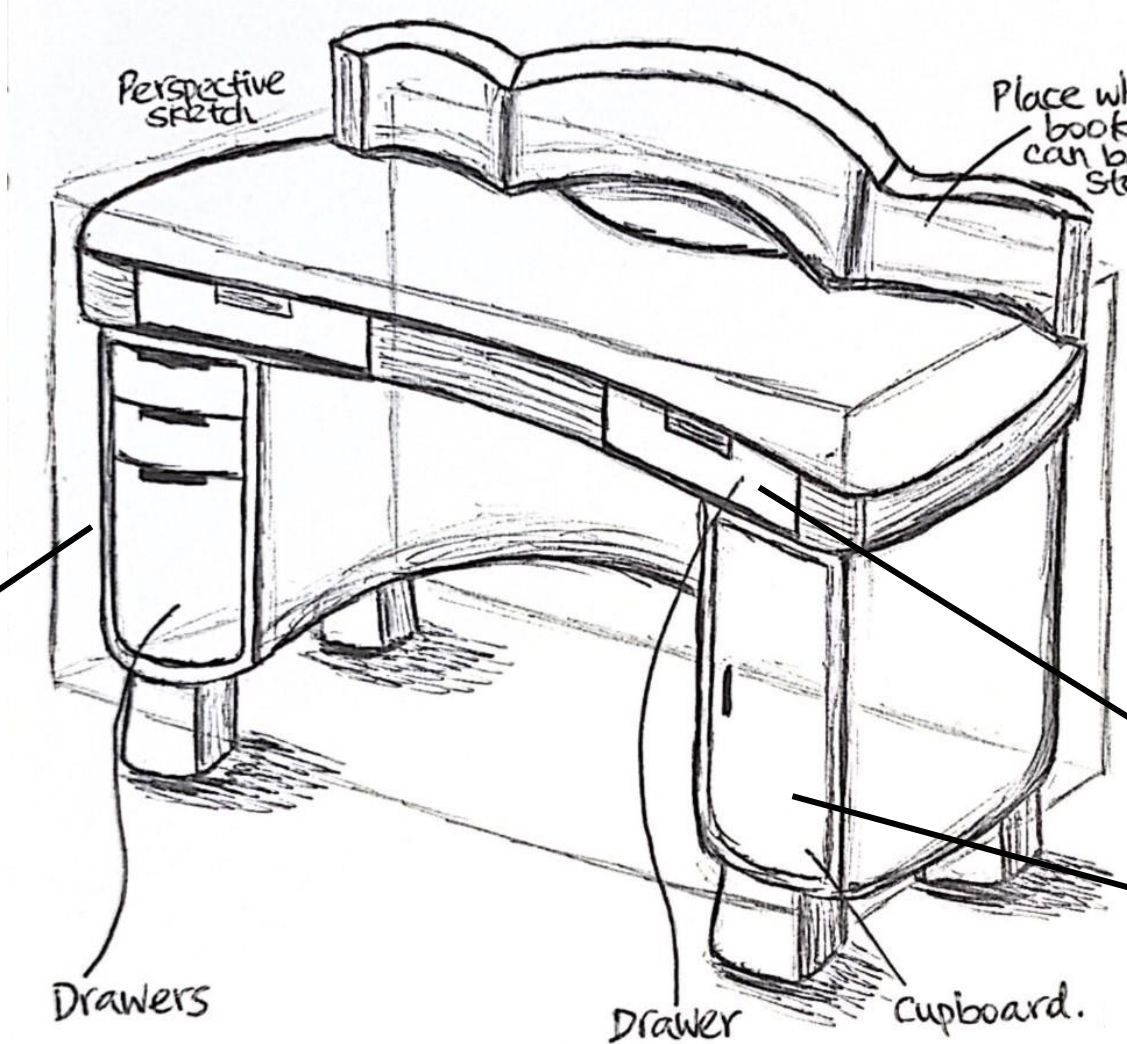

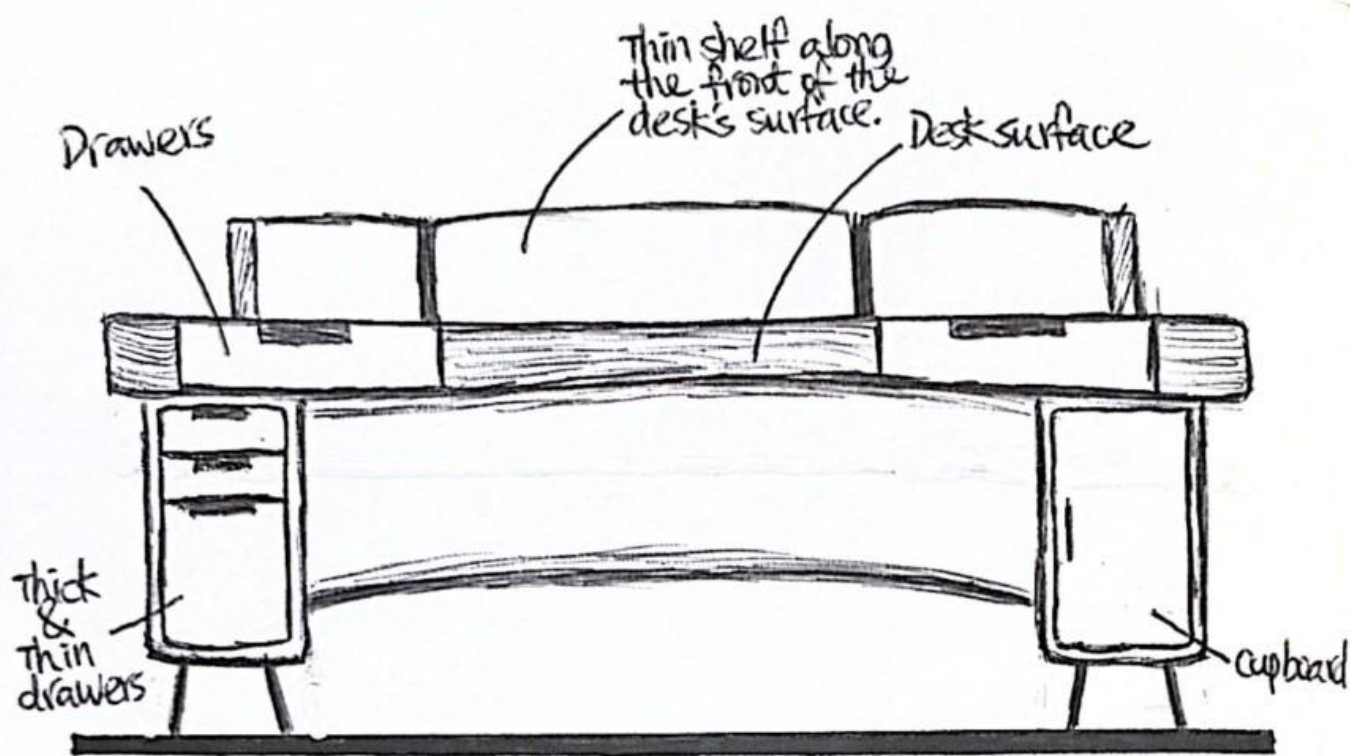

Elevation sketch.

In this desk design, I have included a range of features, so that the user will feel comfortable to use. For example, I have designed drawers and cupboards for users to store stuff, which save up spaces, and keep things tidy. Another feature is that on the desk surface, I have designed a structure, that acts as the book storage space, where books can be stored in a neat pile, like a bookshelf. This prevents the desk surface getting messy, without having spaces to store books. Designing desk features have let me understand the ways to save up spaces and keep things tidy, so that this can make the user feel calm to study, rather than having things all placed on the desk surface, which can make the user feel annoyed and difficult to find stuff.

The plan view of this desk is inspired by the watermelon and lemon slices, but I have made some developments with some features included. Therefore, the shape of the desk starts to change a bit bigger and wider, so that the user have the chance to sit on the desk comfortably, with a wide surface.

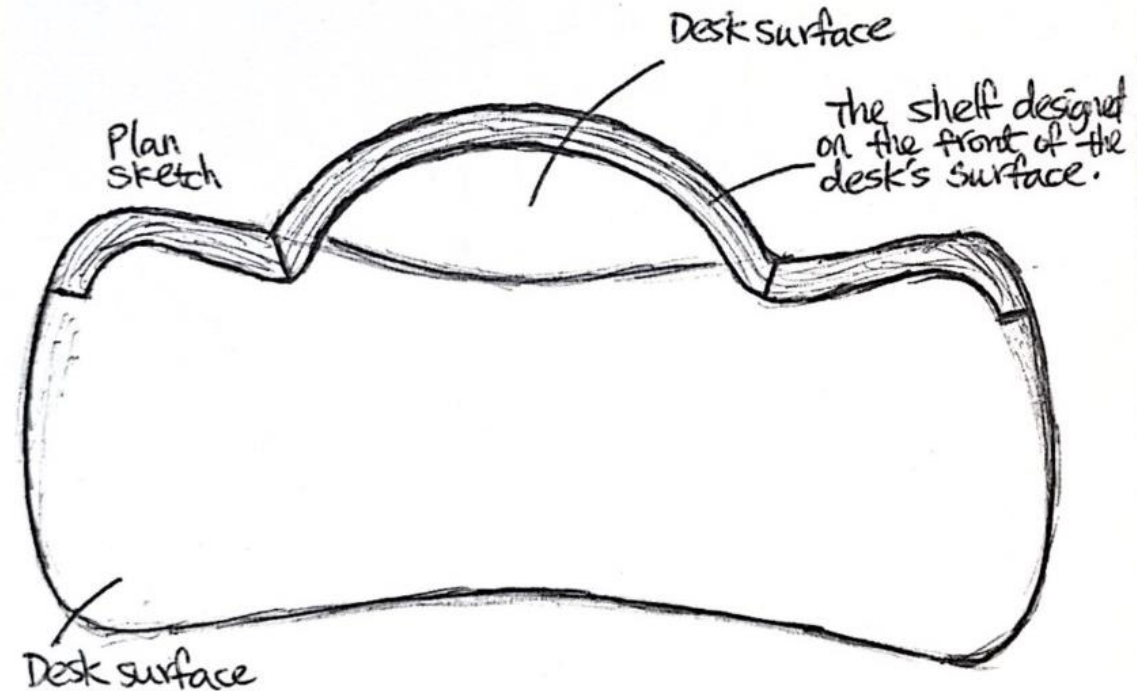

Model: Prototype

(I have used card to make some features combined with the desk to test and help me in the next stage of development.)

In this model, I have used thin cardboard to make the curved cupboard's doors, which are attached to the left leg of the desk, to test out and see if the design works out. Furthermore, I have used thin cardboard to make another curved structure attached to the right leg of the desk, which is going to be a storage area.

After experimented making extra features attached to the desk has taught me the ways to make a multifunctional product. For instance, when I was making the model, I just kept looking around at the shapes, and thinking about how they can work together, without wasting any spaces. Also, I was thinking about the ways to design a desk that can make the user feel comfortable using it, and find it easy to store and organise things.

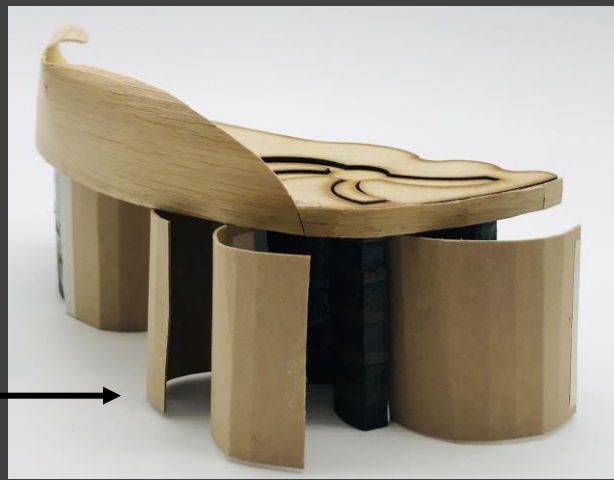

Curved
cupboard's
doors

Curved
structure

Development Desk Features for Desk Design 5

In this desk design, I have created a range of features that blends in with the shape of the desk. For instance, I have designed 3 curved & bumpy cupboard's doors attached to the left leg, that reflects the texture of the organic nuts. On the right leg, I have also designed some storage spaces, such as drawers and a cupboard. On the desk surface, I have designed some desk organisers.

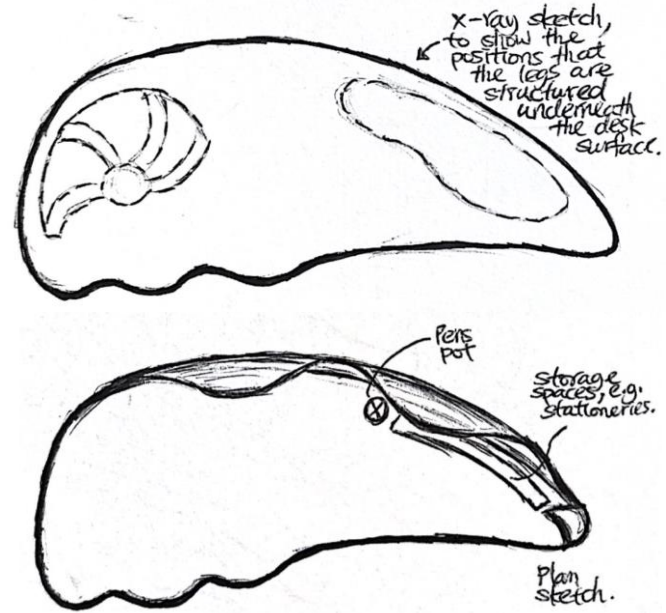
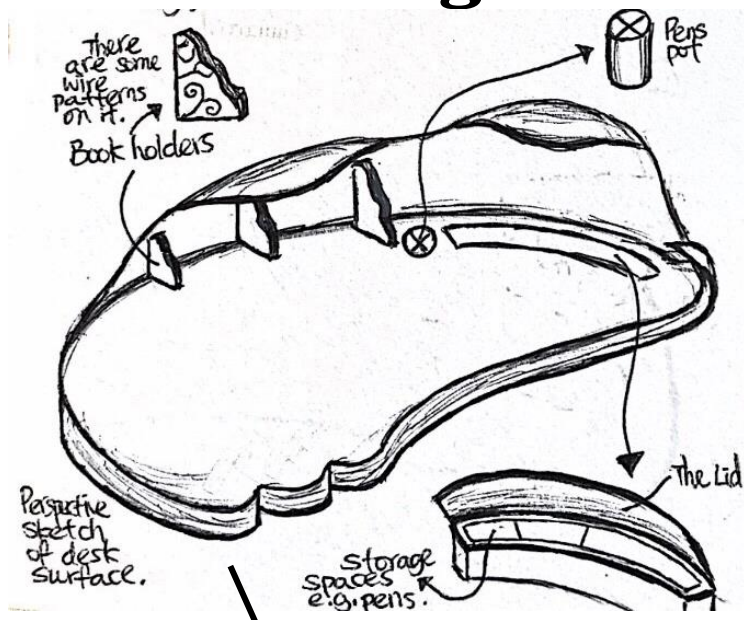
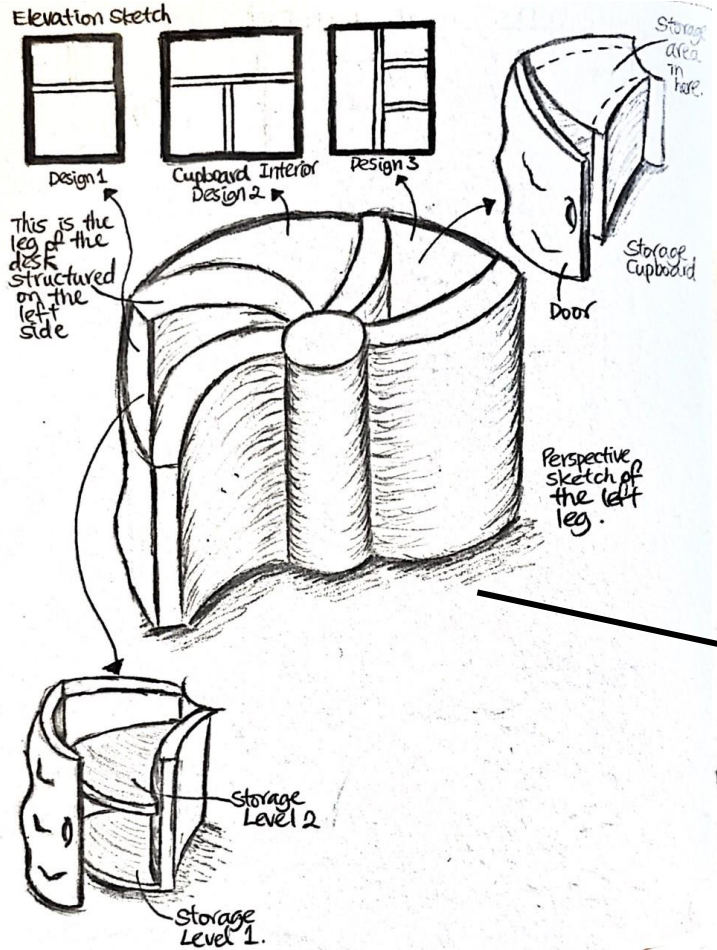

These are the plan sketch of the desk surface.

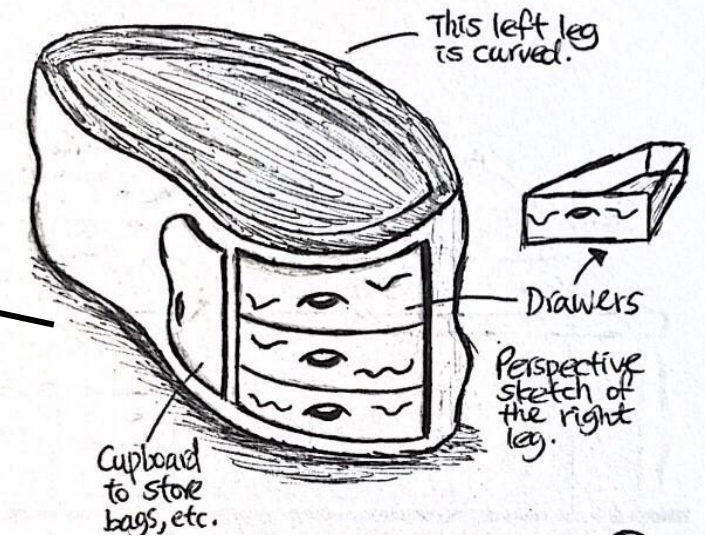
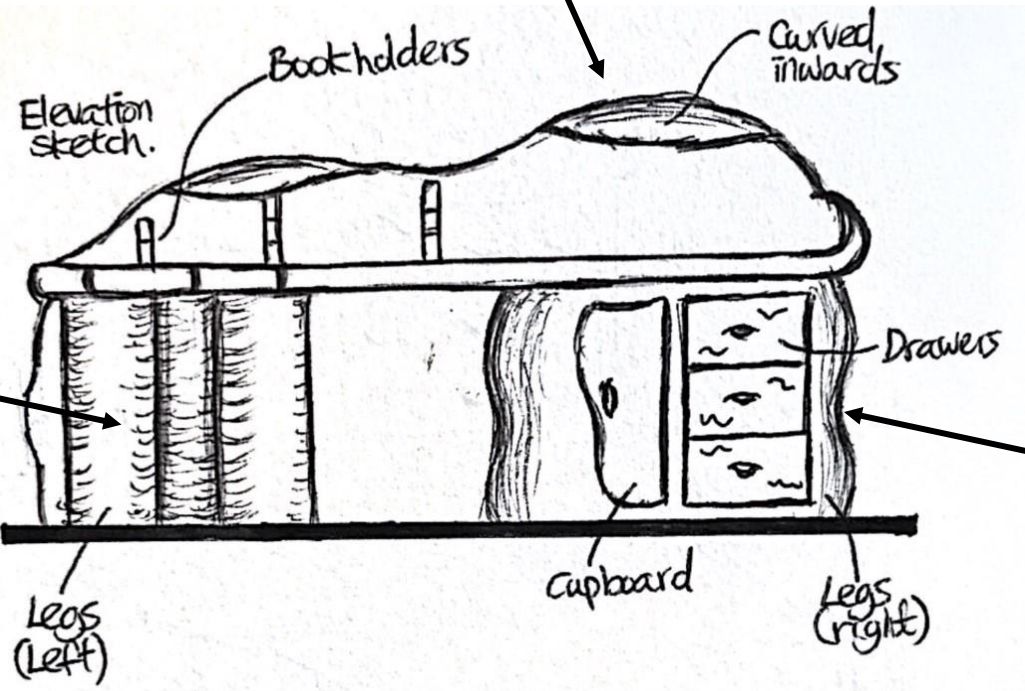

Record: Desk Design 5's Features Development

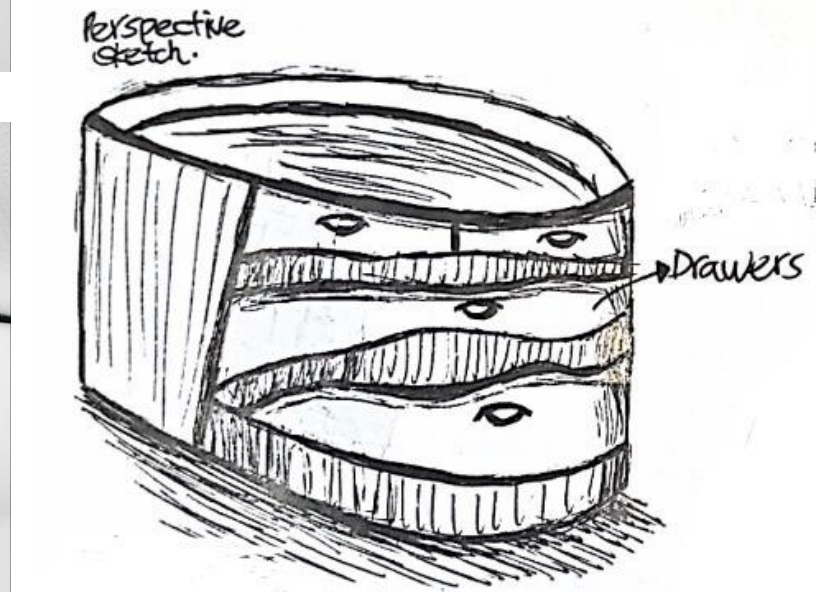
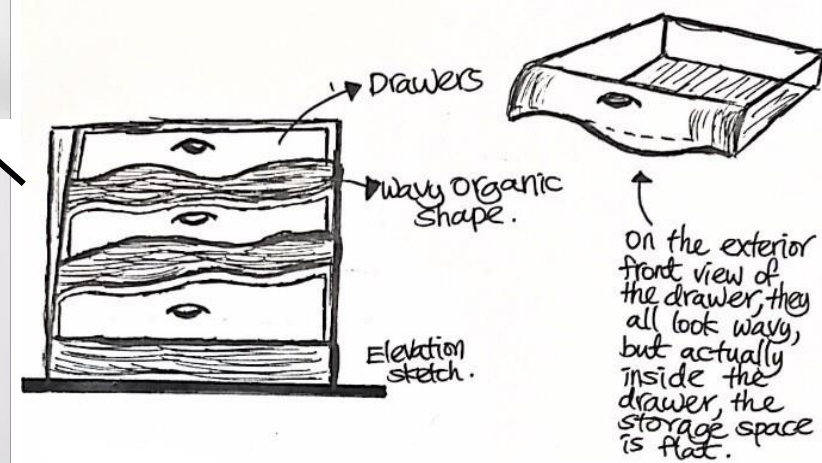

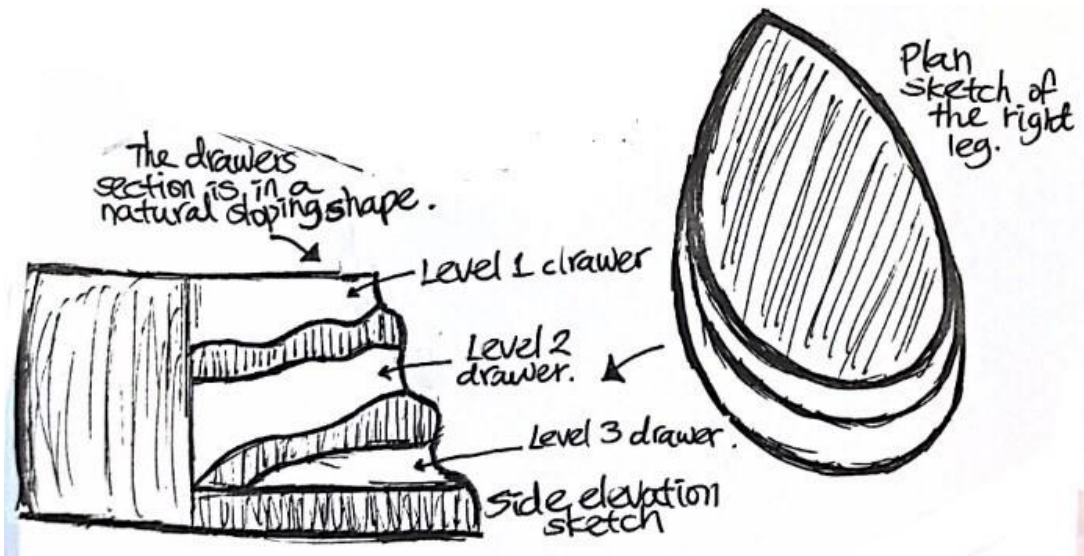

Here, I have developed the desk features using better materials, and in much detailed. For instance, on the right leg, I have used veneer wood to create better texture for the drawers, in wavy pattern, that are in a sloping shape. On the left leg, I have created storage layers using MDF wood, then used the veneer wood to create cupboard's doors, and used wire to make the cupboard's door handles.



Scale-Up Desk Design 5

Prototype: Sketches of the construction of the desk using wood joints.

I have sketched out the desk design 5 into separate parts to see how to join the pieces together without using glue, and the type of wood joints I'm going to use to make the parts join strongly. For instance, I have thought of using different wood joints to form the desk shape, including mortise & tenon joints, biscuit joints, and dowel joints. However, after doing some sketches, made me realised that I do not need that many types of wood joints, and I only need to combine some of the parts into one shape, rather than using wood joints to combine those shapes.

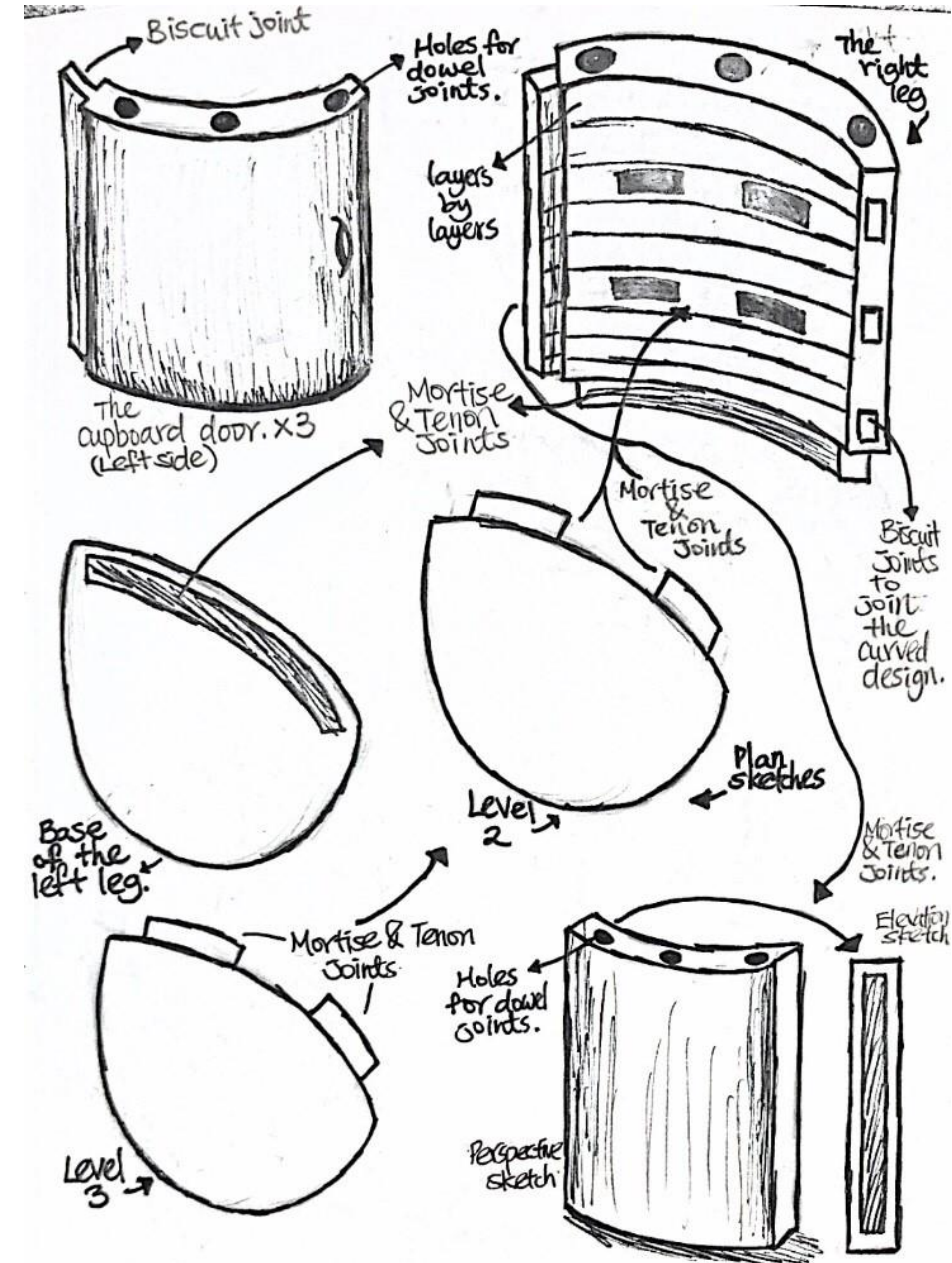
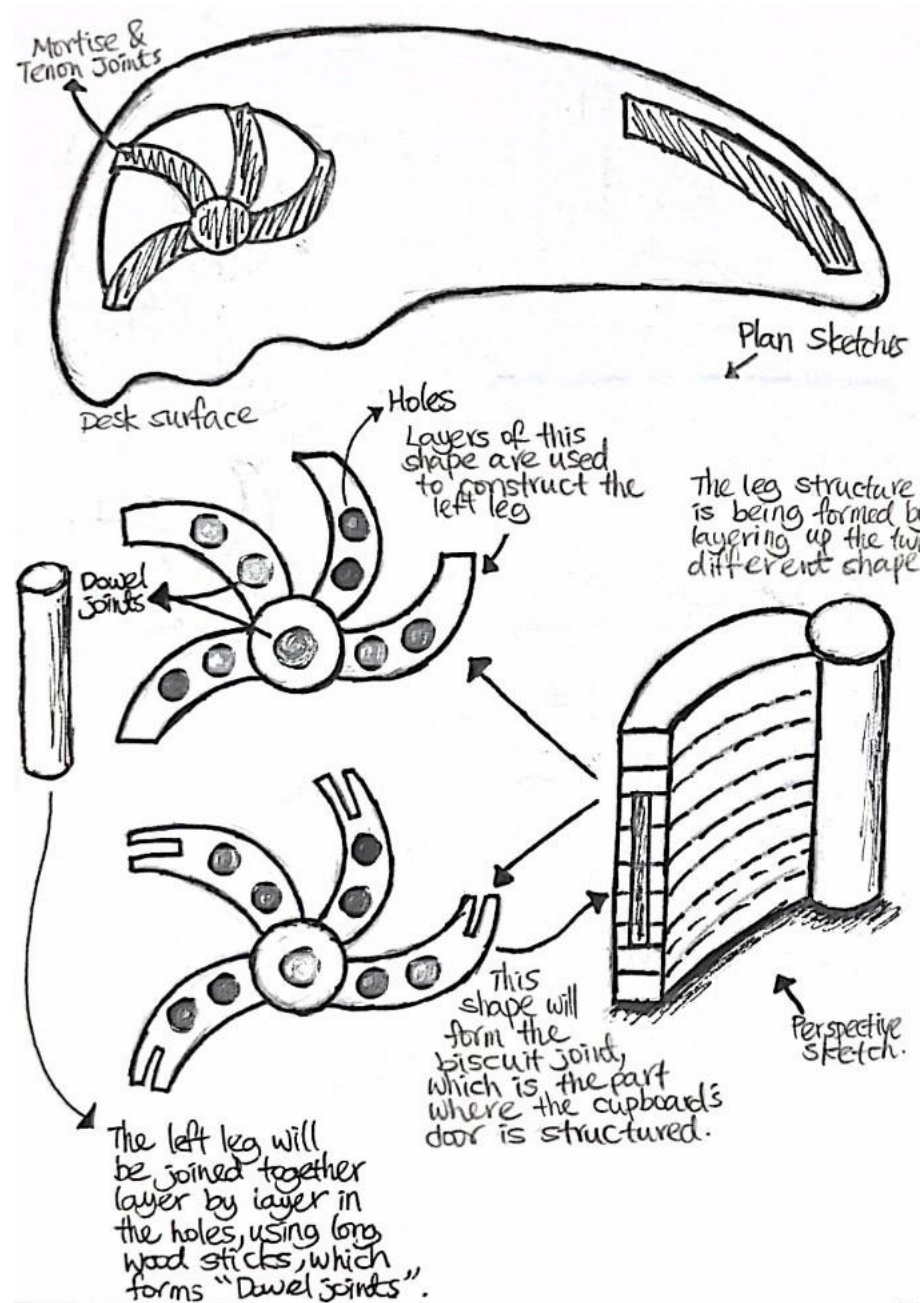

Scale-Up Desk Design 5

Record: Modelling Desk Design 5 using 2D Software & Laser Cutter

I have used the 2D Software to draw the features of my desk design, which will be laser cut onto MDF wood, and then later I will construct the pieces together into the 3D desk. In this design, I decided to use wood joints to join the pieces of woods together, rather than using glue. For instance, on all the features of the table, I have drawn circles, which are holes for the "dowel joints", that I'm going to use to join the pieces of features together.

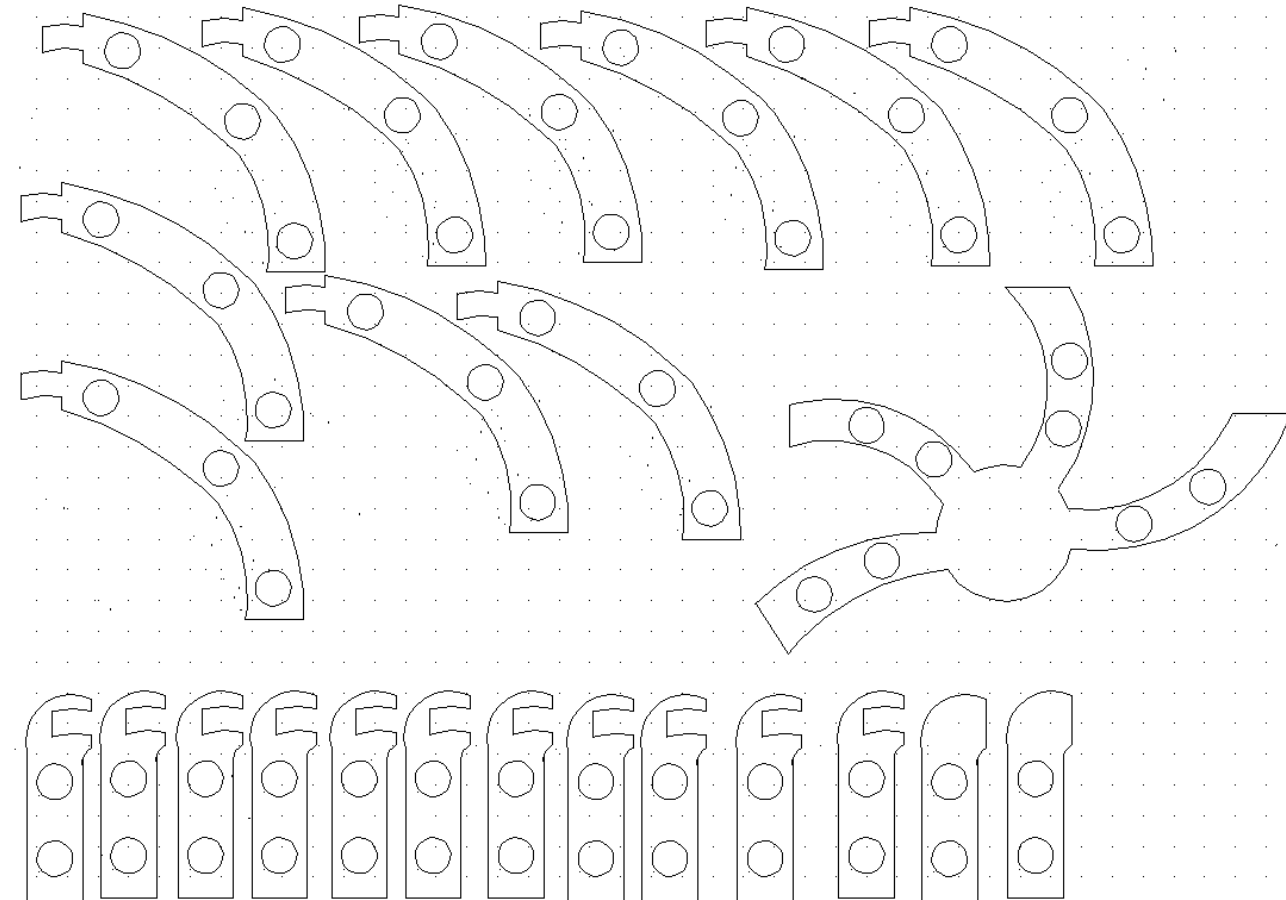
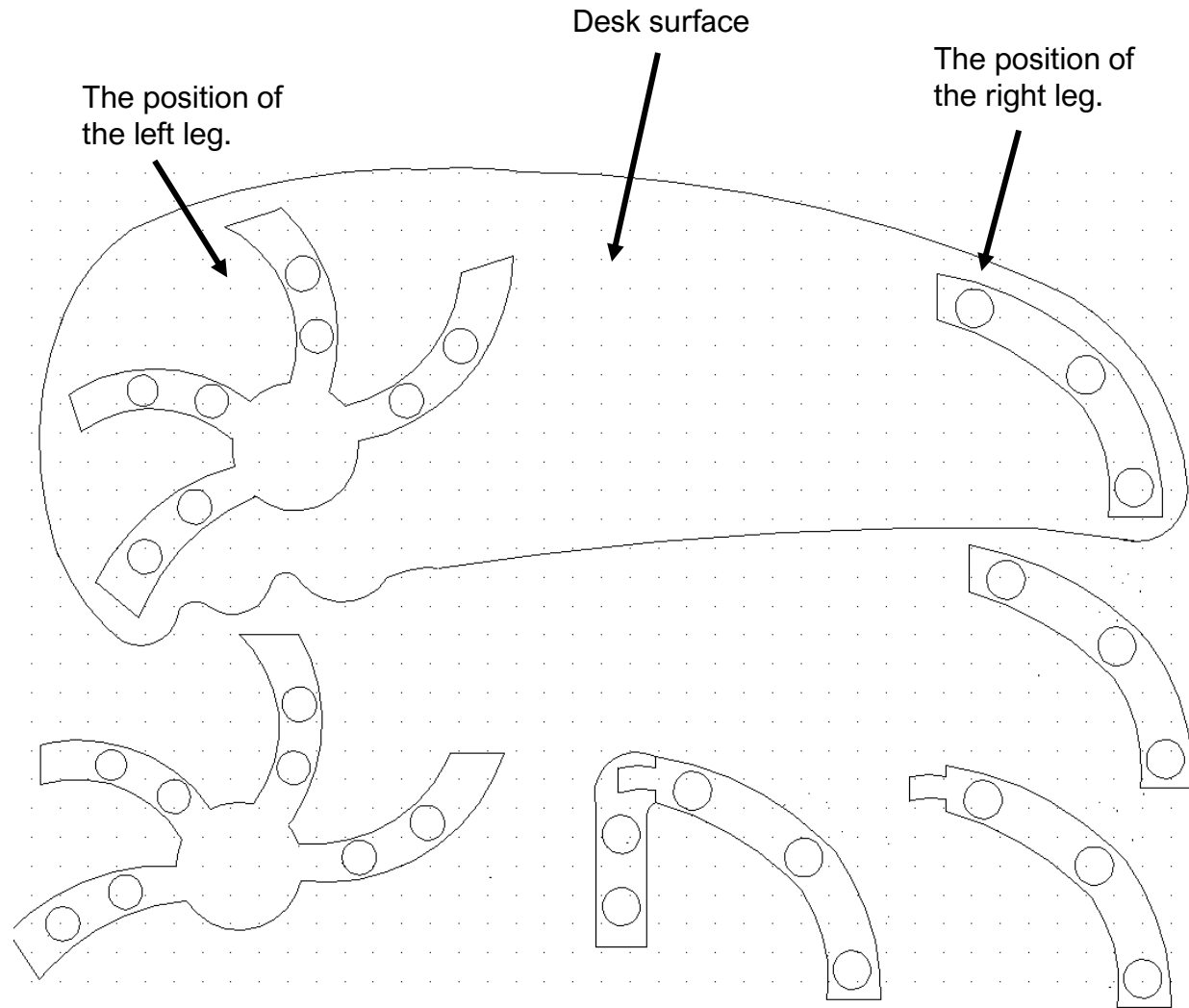

These are the features of the left leg, which are going to be layered up together, and turn into shelves, where the users can store stuff.

These are the features of the right leg, which are going to be layered up together to form a shelf shape, and then the drawers' runners will be structured inside the shelf shape. So that the drawers can be placed in the shelf.

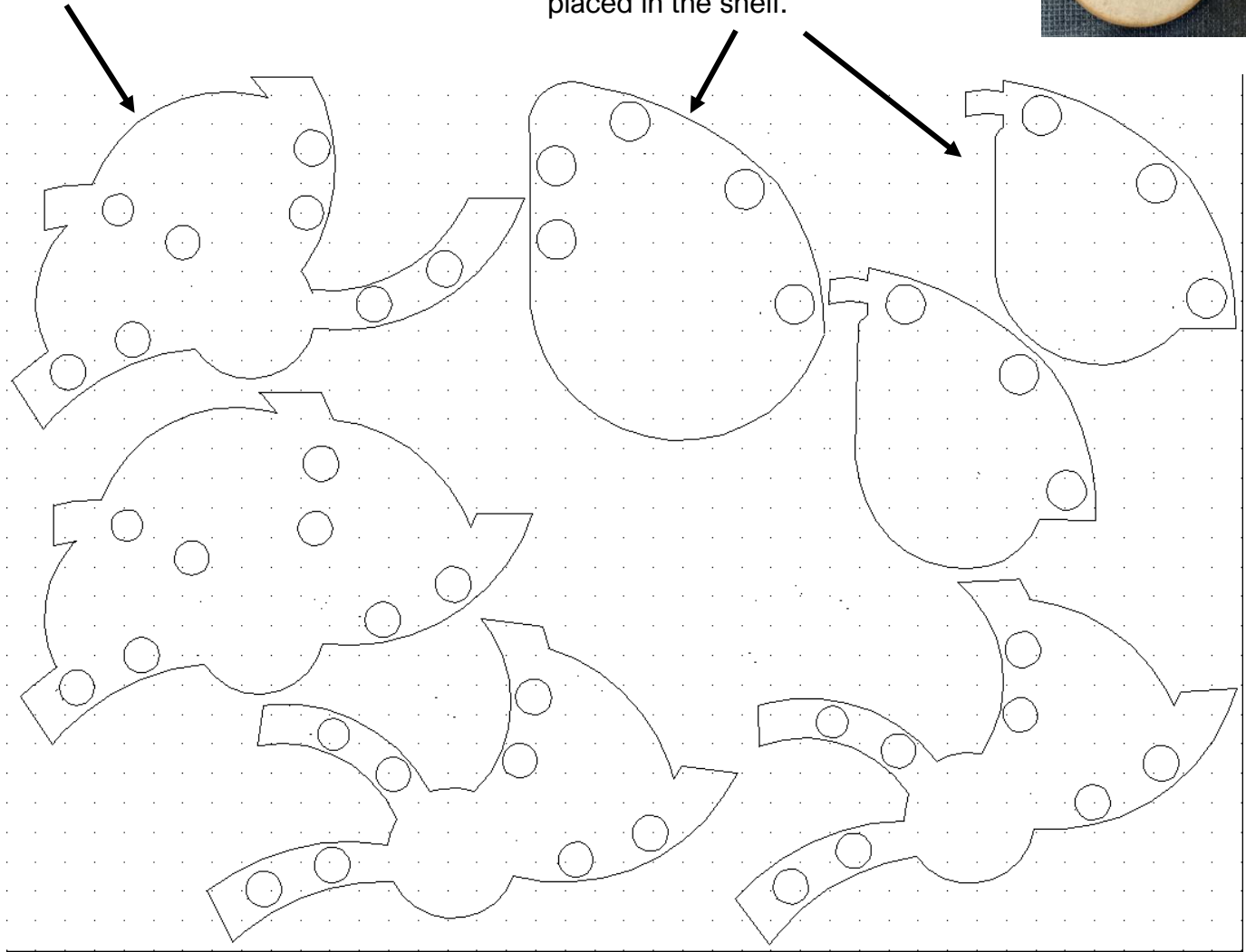

Scaled-Up Desk Design 5

The scaled-up desk design 5 has been made of MDF wood and I have used wooden dowels to join the pieces together to form the design.

Making the scaled-up desk model (shown on next page) has taught me the ways to form a huge model. For instance, I have learnt that in order to make a huge leg using MDF wood, I need to layer up the same design. And dowel joints is a great joining technique to use when I am layering up pieces of wood.

I really like the way that I have designed the shelf, which looks very nice and strong. Also, the scaled-up desk design turned out to be great, and exactly like the smaller version that I had previously made.

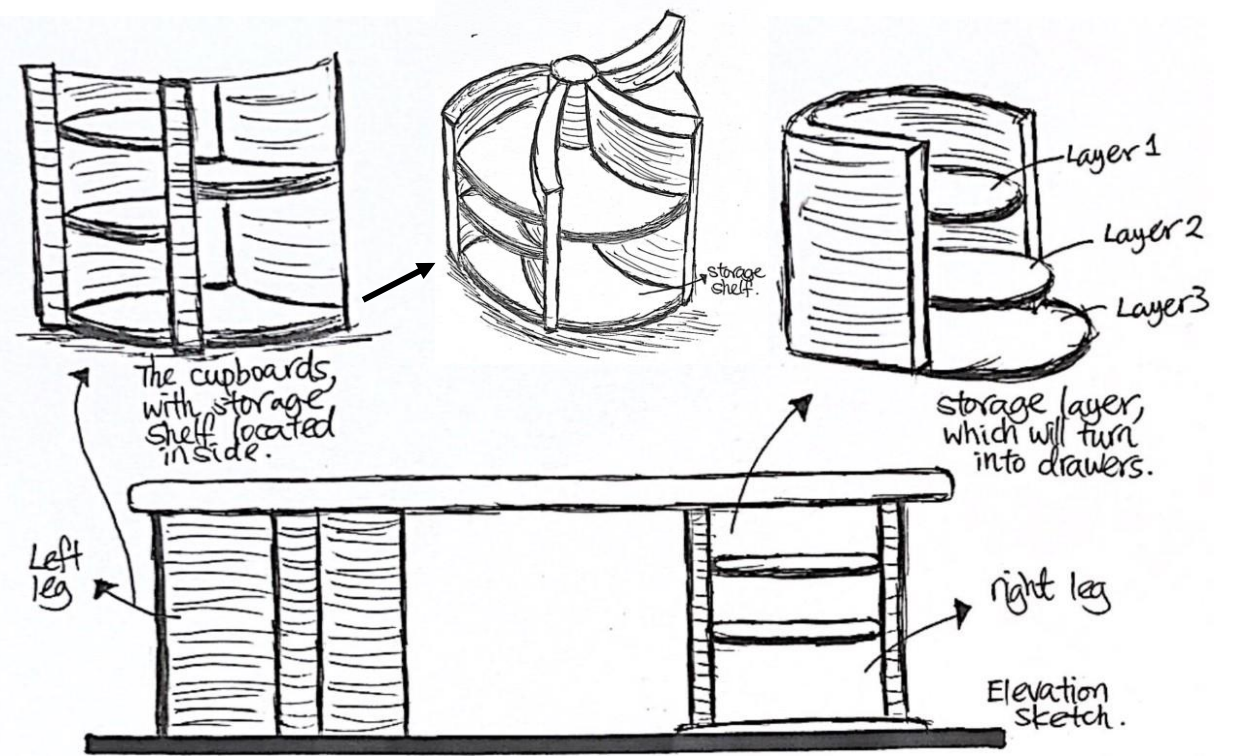

Smaller Version Desk Design



I have used the collage technique to show a person using the scaled-up desk design, and to roughly show the scale of the design.

Scaled-up Desk Design

Record: Constructing Scaled-Up Desk Design 5



Final Scaled-Up Desk Design 5

Front View



Plan View



The cupboard's shelves for storage.



Back View



The “final scaled-up desk design” has been made using various materials, which includes MDF wood (main structure), foamboard, russet brown felt and cards. In this design, I have used wood joints to construct the main desk structure with cupboards’ and drawers’ shelves included in it. The cupboards are designed on the left leg of the desk, and the drawers’ shelves are designed on the right leg. After that, I used simple materials to construct the desk features to make them stand-out. For instance, I have constructed book holders on the desk surface using foamboard, and doors for the cupboards using thick cards.



Process: Finalise & Scale-Up the Portable Storage Organiser Design, Strawberry Inspiration

Sketches to show the construction of the portable storage organiser

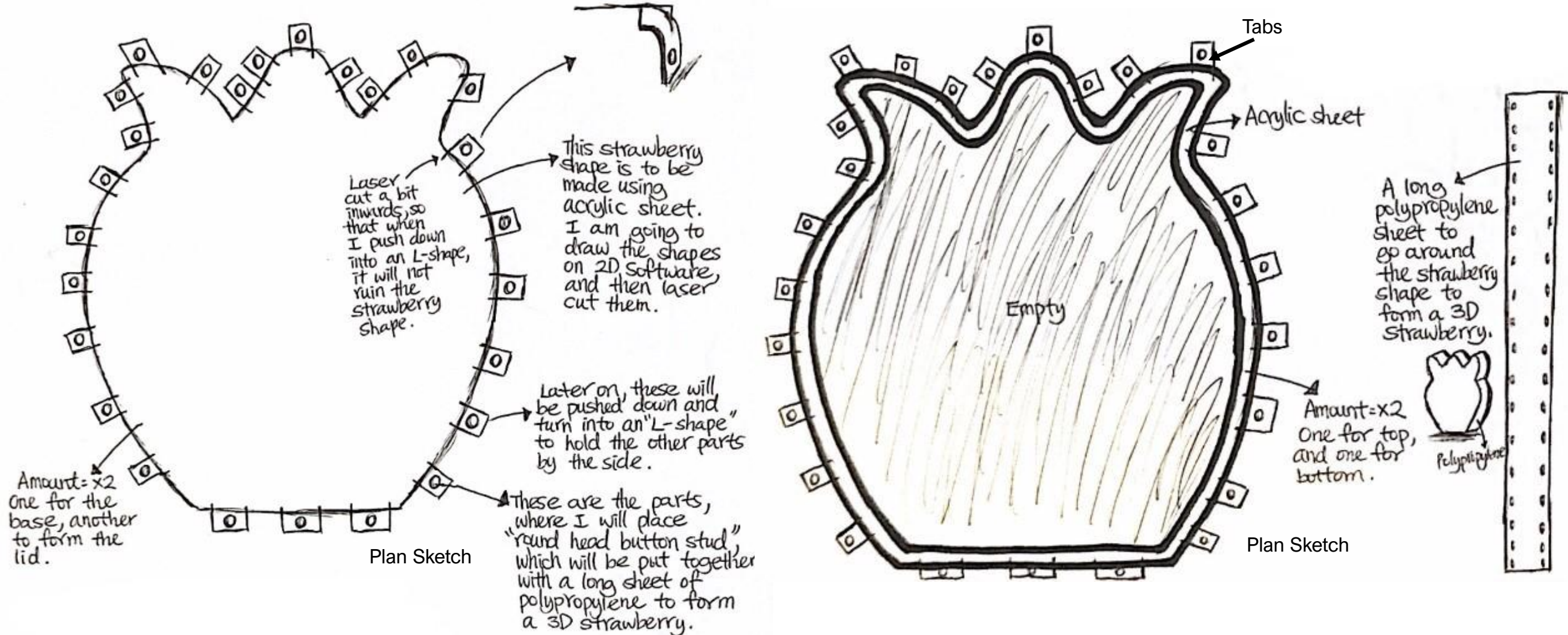

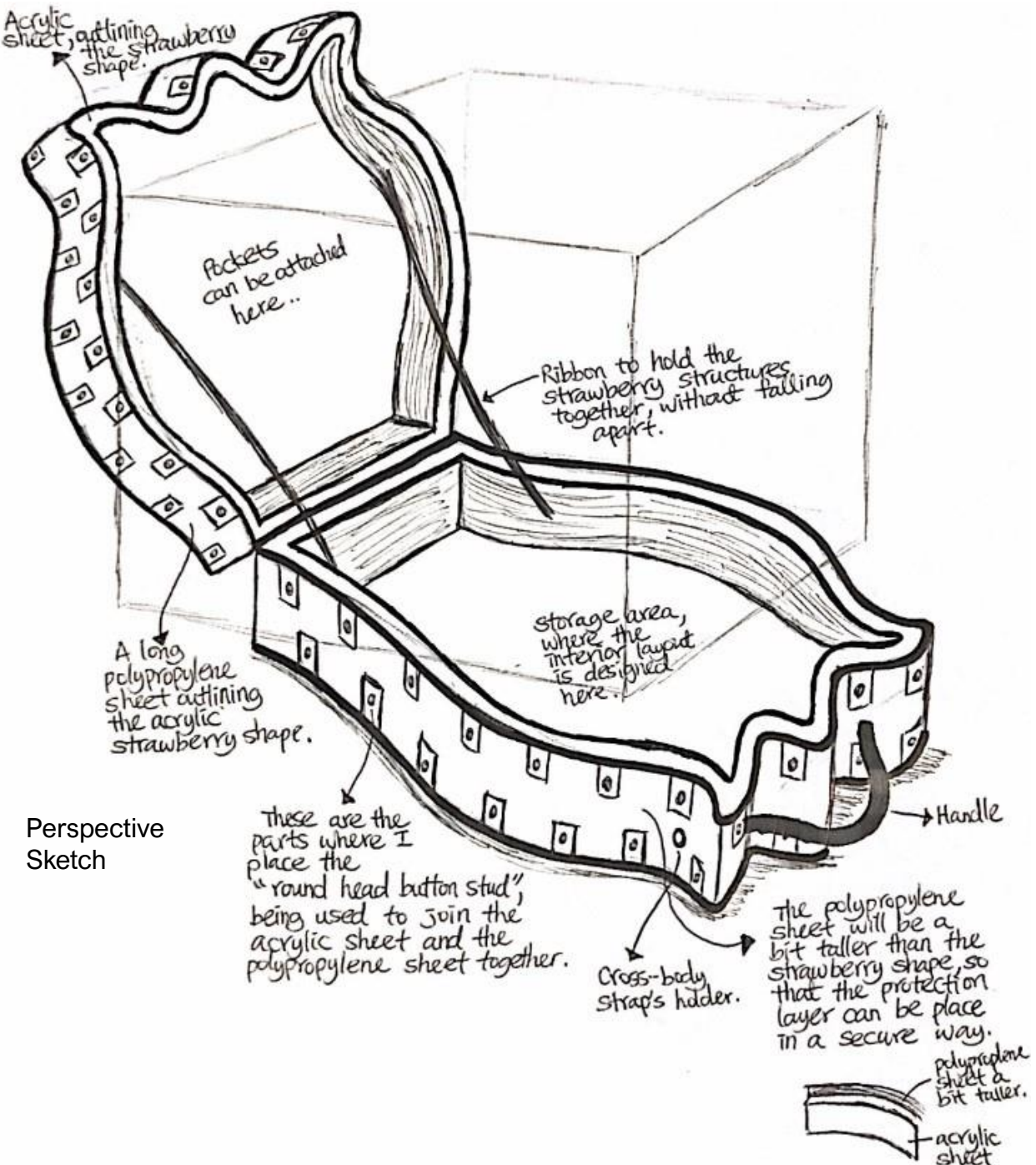

Perspective Sketch

In the final model design, I have decided to challenge myself to use a different material to construct my storage organiser design, which are acrylic sheets and polypropylene. Here, I have sketched out the way in which the organiser is going to be formed through the use of different cut-out shapes with tabs included, in order to construct all the pieces together.

The materials that I decide to use for the final scale-up model:

- Acrylic Sheet
- Polypropylene
- Button Studs
- Wire (Thin/Thick) to add details, which is part of the design.
- Cross-body Strap
- Ribbon



Polypropylene Sheet



Wire

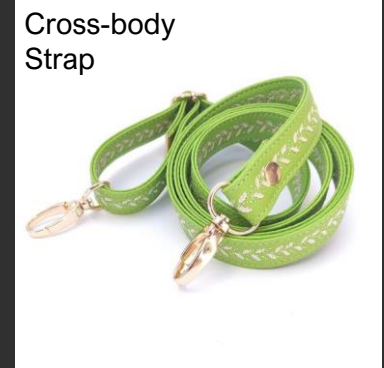

Cross-body Strap



Acrylic Sheet



Studs

Process: Finalise & Scale-Up the Portable Storage Organiser Design, Strawberry Inspiration

Record: Modelling the Storage Organiser using 2D Software & Laser Cutter

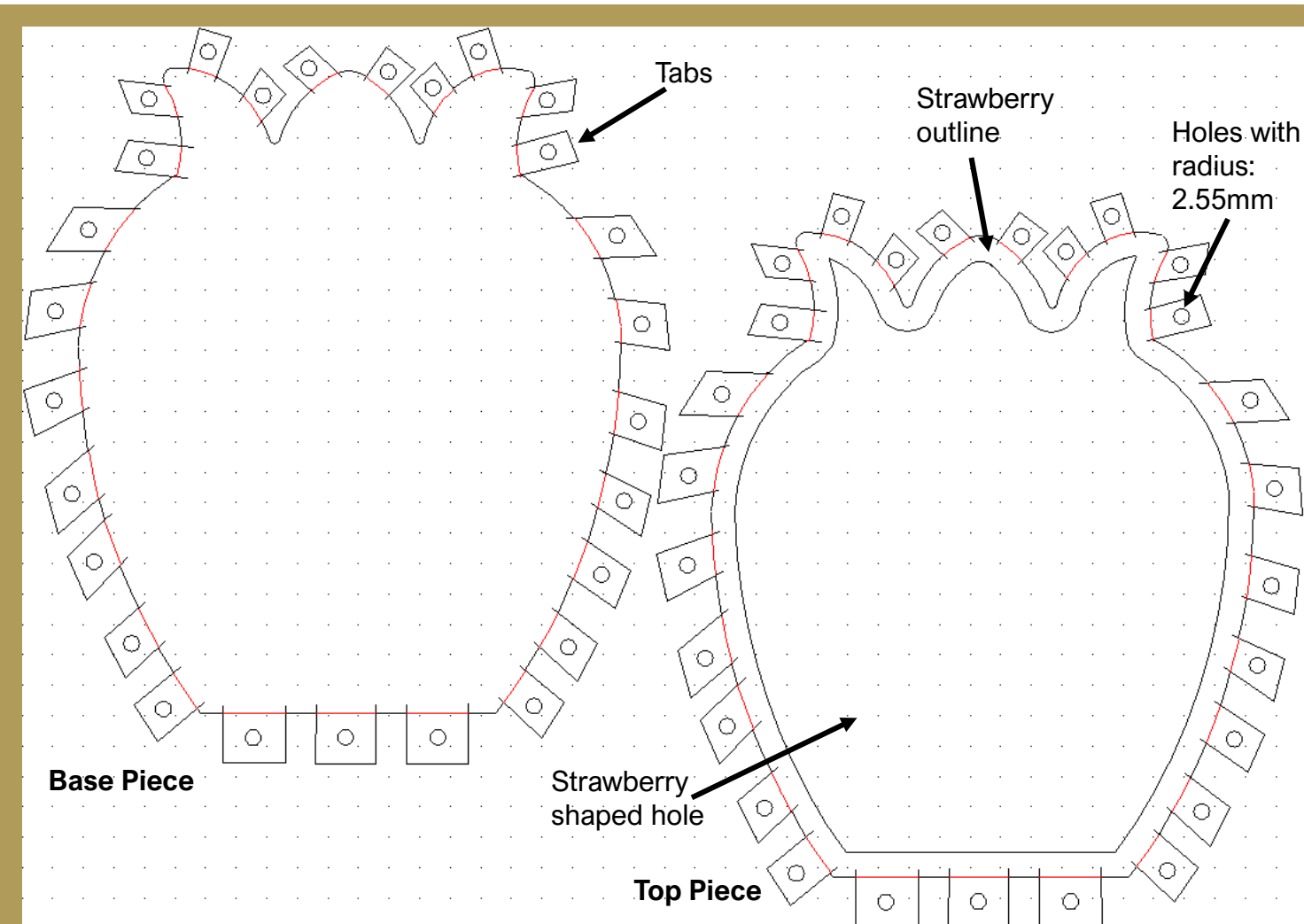

Here, I have drawn the storage organiser's template on 2D Software. The two drawings on the left are the pieces used to construct the storage space of the organiser. The "Base Piece" is the piece where the objects are going to be stored on. The "Top Piece" is the piece that is constructed on top of the base piece, but there is going to be a piece of cardboard strip constructed in between the two pieces of strawberry shapes to form a thickness for the storage organiser.

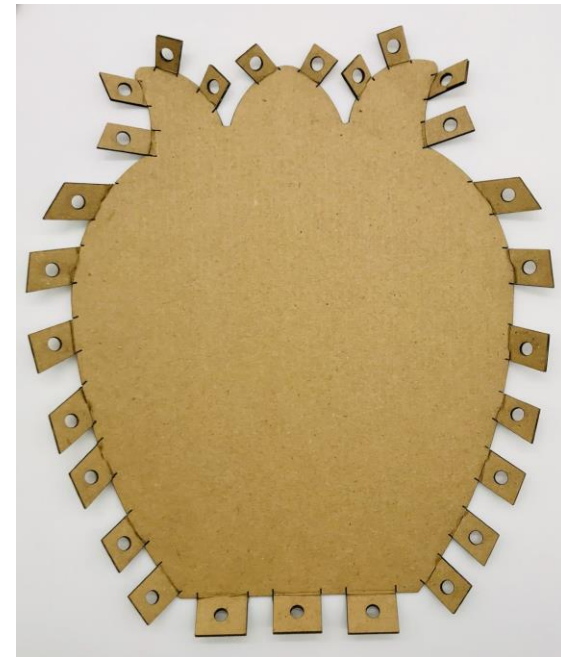

Prototype: Laser cut the design onto cardboard to test and see if the idea work.

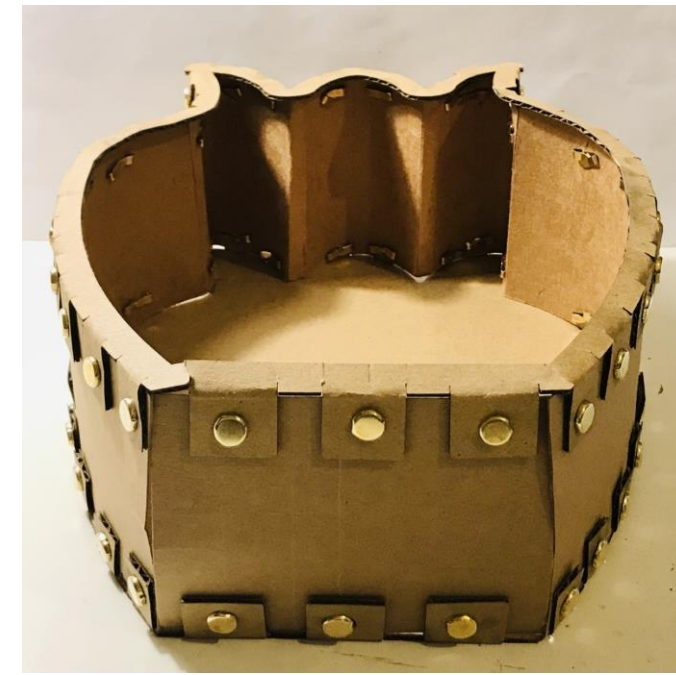

After I had laser cut the design onto the cardboard, I started to join the pieces together to see if the idea work. In this modelling process, I had used "paper fasteners" to join the pieces together, to form the 3D strawberry shape design.

My Analysis:

All the tabs are supposed to be hidden on the interior of the organiser, not to be seen. But I accidentally constructed them on the exterior, which was the wrong way round. My original idea is to hide the tabs on the interior side, so that my design will stand-out, rather than a range of tabs structured on the exterior side, distracting my design.

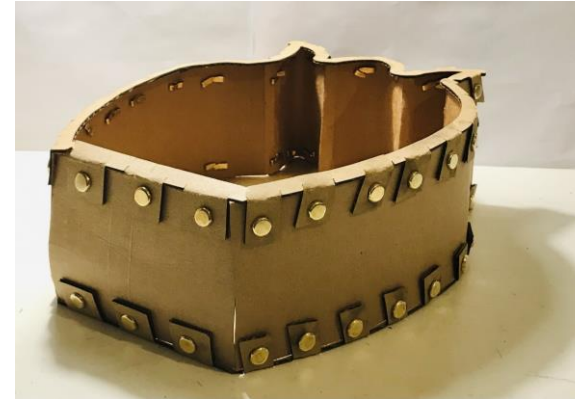

Tabs hidden on the interior side.

Tabs accidentally structured on the exterior side.

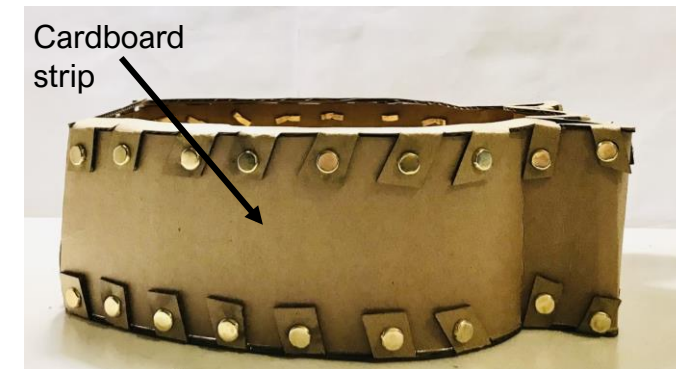
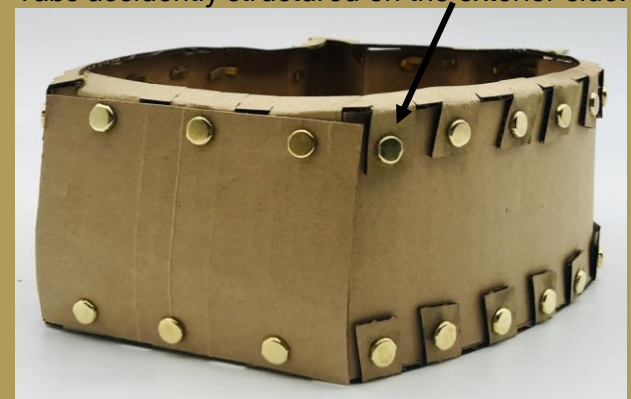

Prototype: Developing Lid & Locks on the Storage Organiser Model

In this stage, I have constructed the lid onto the design, and created locks by the left and right sides of the organiser. Making the storage organiser in this way works out to be good. Therefore, I have decided to make the final storage organiser using the same 2D Software drawings, but using better materials, including acrylic and polypropylene. Also, I am going to add features onto the final model, including a handle, cross-body strap and the construction of the interior layout.

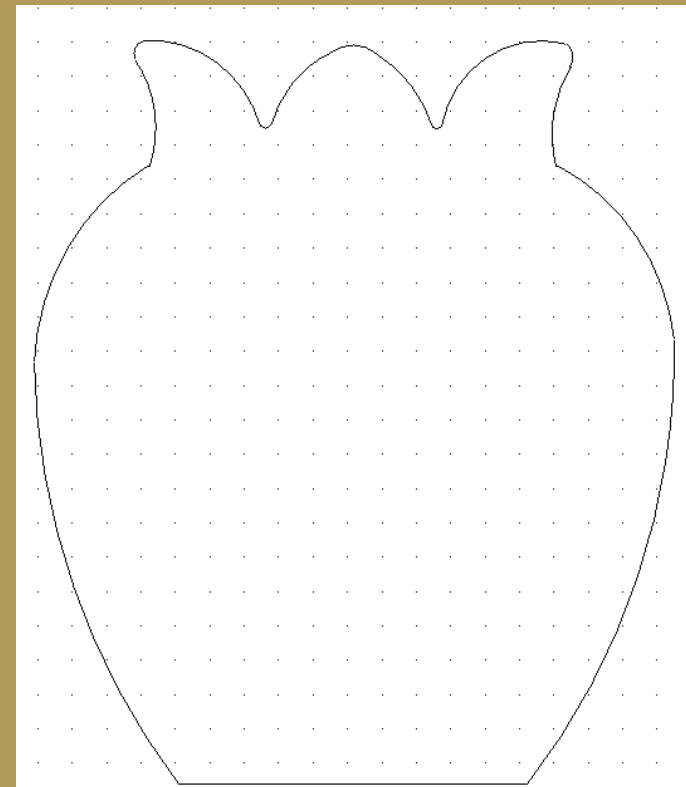
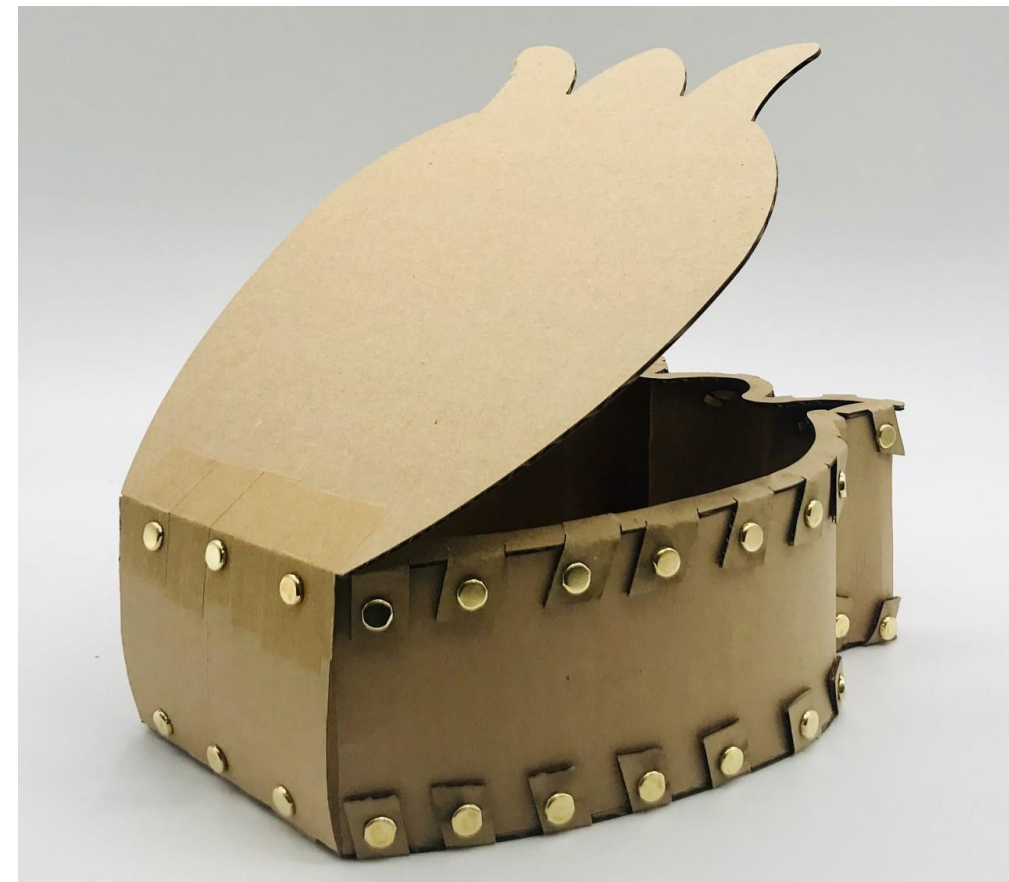

On the 2D Software, I have drawn another strawberry shape for the lid. While constructing the pieces together, I have thought of a way to design the lock. The idea is that I could design two tabs on the lid with two tiny holes on each of them, that match up with another two holes that are cut by the left and right side of the organiser. Later on, I could tie strings on both of the two holes by the left and right sides, to secure the lid and organiser. Therefore, I have experimented the idea on the cardboard model and the idea have worked.



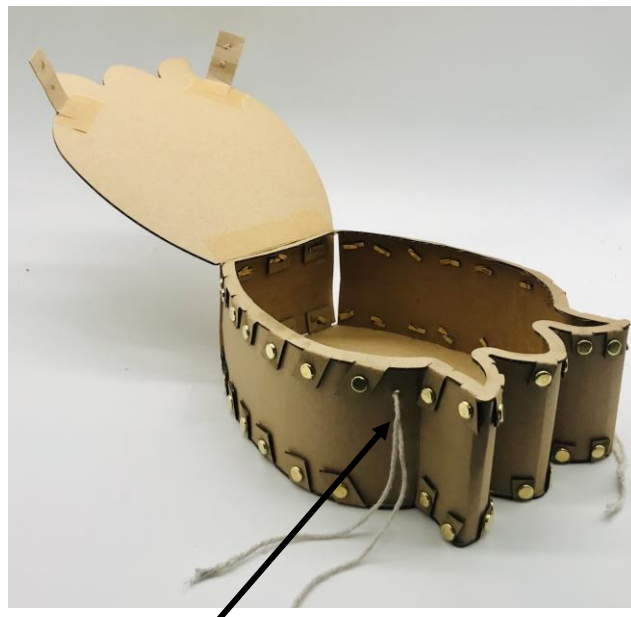
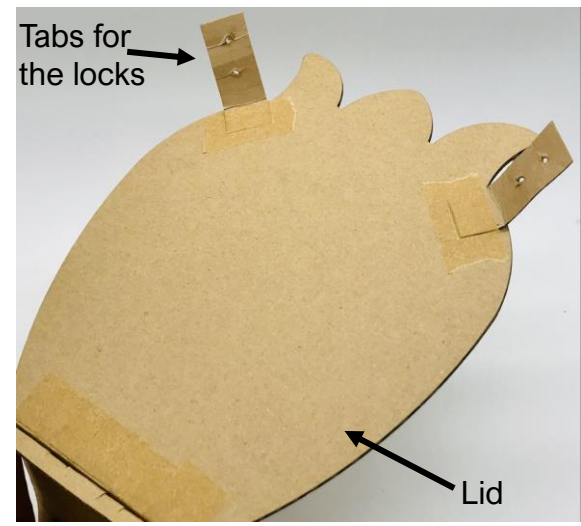

Two tiny holes on both left and right sides for using the sting strings to lock the organiser.

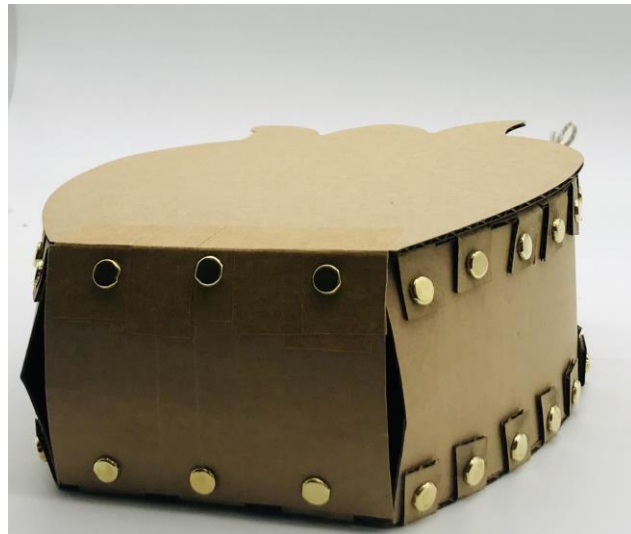
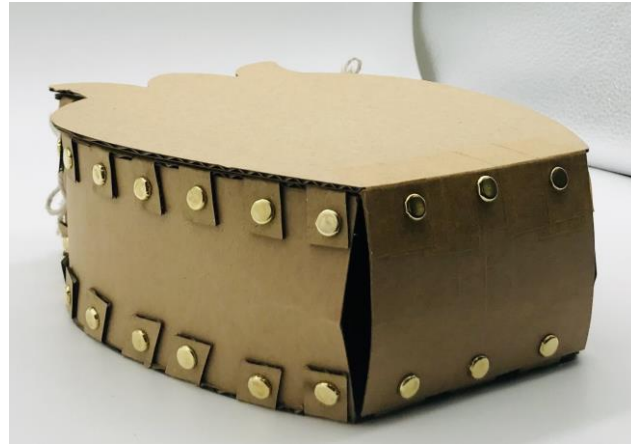

Secondary Research: How to bend acrylic in a nice way?

Acrylic Bending Machine

An “acrylic bending machine” is a useful tool for softening and bending acrylic sheets. In order to use the machine, it first needs to be heated up to a certain temperature. After that, the acrylic sheet can be placed on the heater. Wait for the material to heat sufficiently, and then lift the hinged panel to bend it.



Examples of Bent Acrylic (Pinterest)

A piece of acrylic sheet can be bent into a range of products, which includes earring holder, desk, phone holder, book shelf, and more.

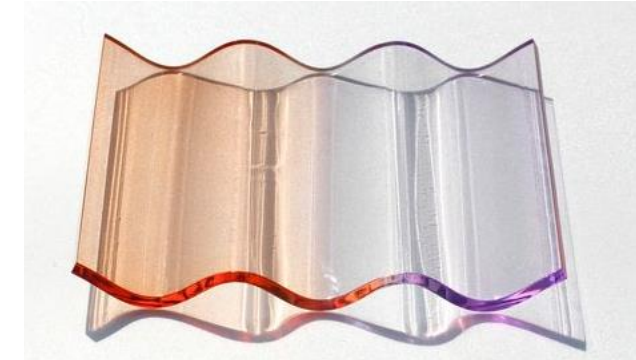

Prototype: Laser cut a tiny part of the design onto an acrylic sheet to see if the idea work.

I have laser cut the storage organiser's tabs design onto a piece of 3mm acrylic sheet. Later on, I have used a bending machine to heat up a tab to see if it is bendable. The result is that the design worked, and the tabs have bended smoothly.

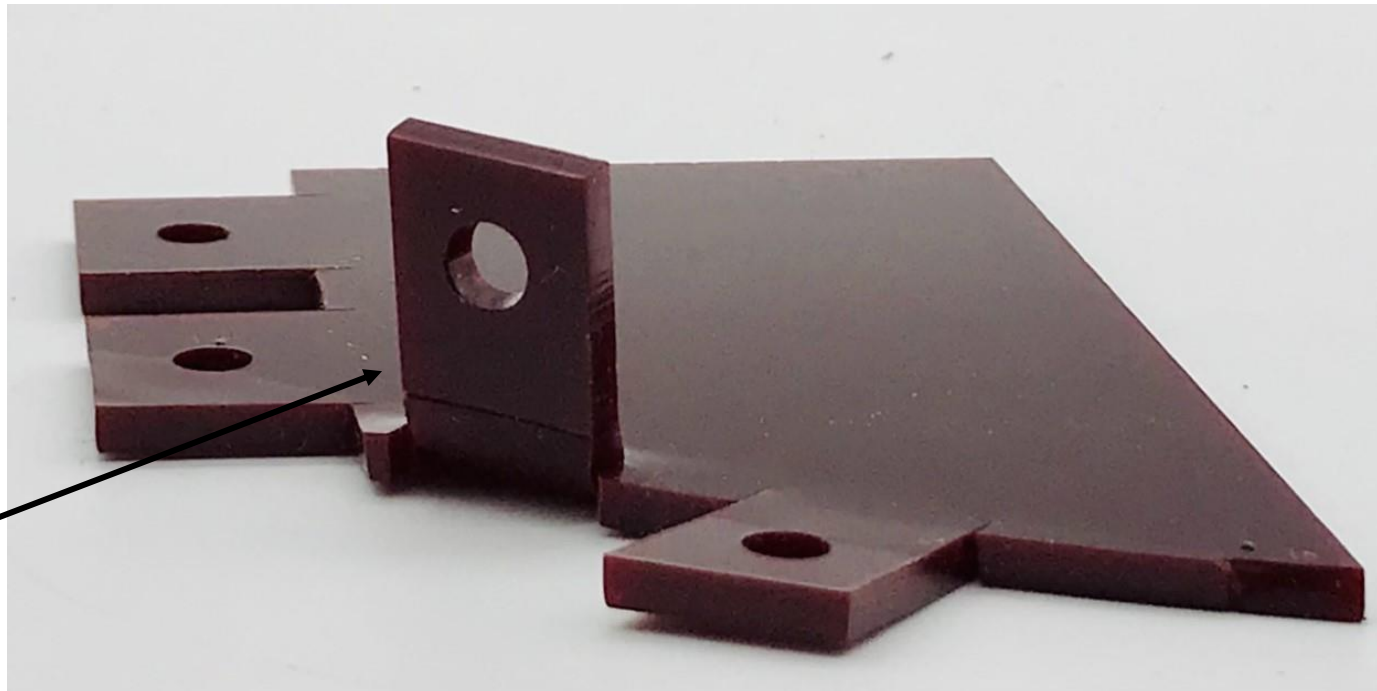
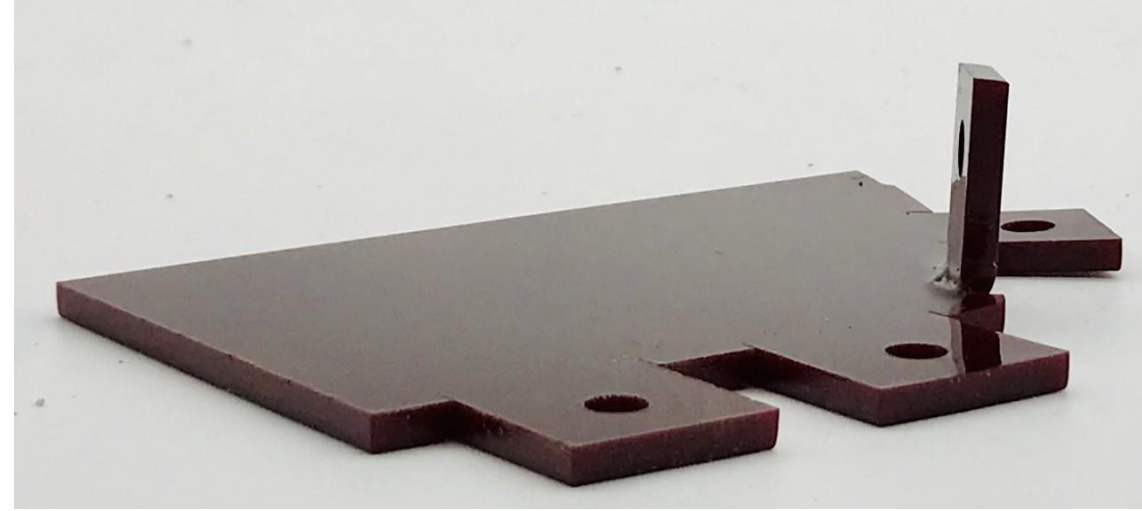
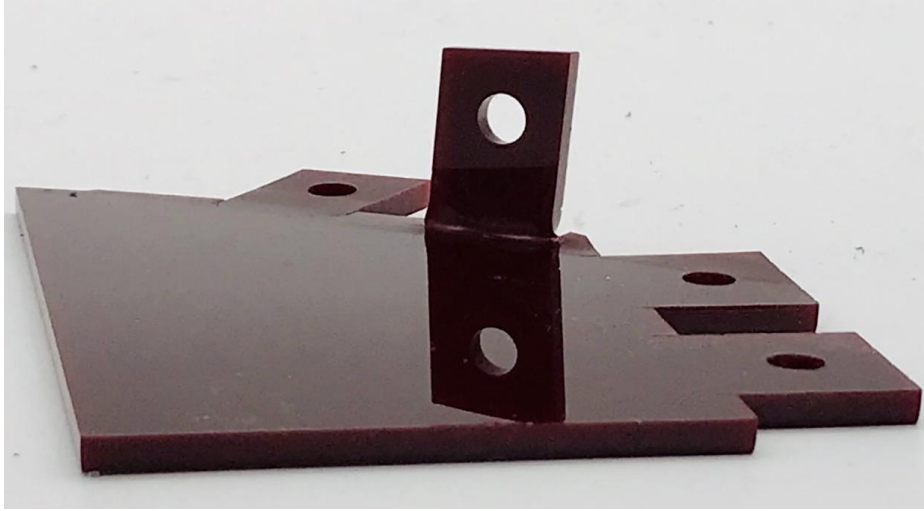

The tab bends in smoothly at a 90 degree angle.

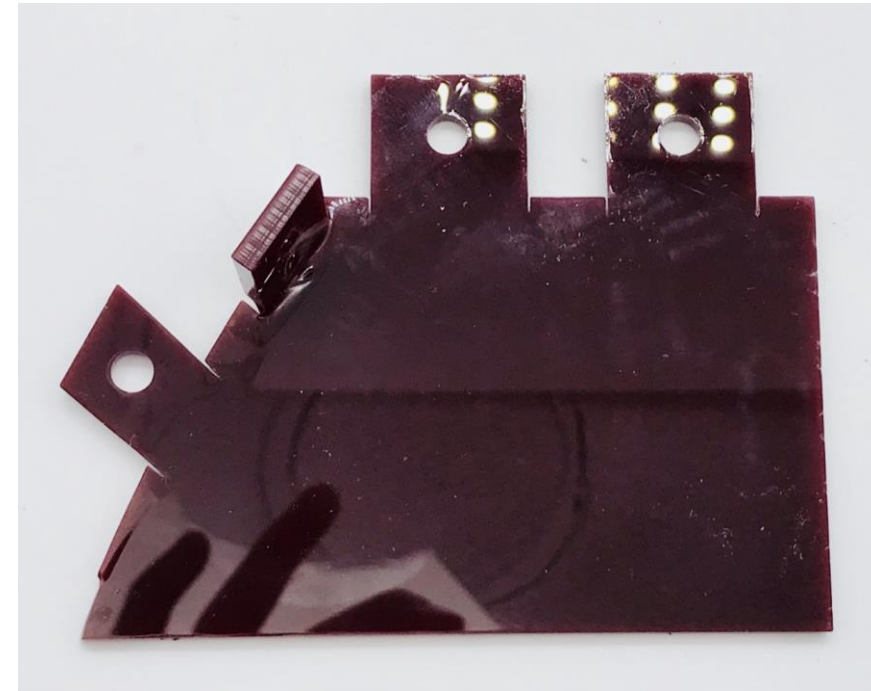

Final Development: Finalising & Scaling-Up the Portable Storage Organiser, Strawberry Inspiration

Record: Modelling the Portable Storage Organiser using 2D Software & Laser Cutter

After experimented the design onto cardboard, I have decided to cut them onto an acrylic sheet. I have also designed a logo for the storage organiser, which I'm going to cut on acrylic sheet. The logo has been designed in a way that shows my initial, "JQ", which also blends in with the final desk design. Near the corner of the lid and the centre of the logo, I have drawn a hole, which they are going to be fit together using a dowel joint.

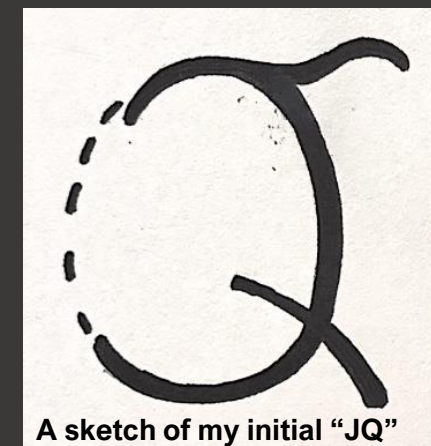
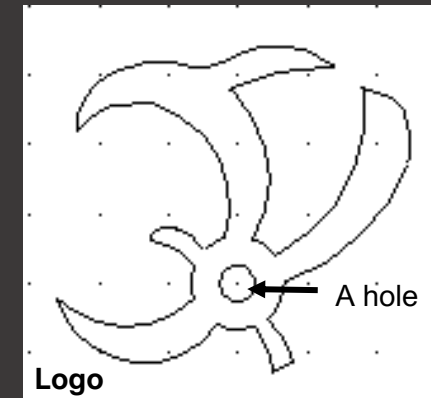
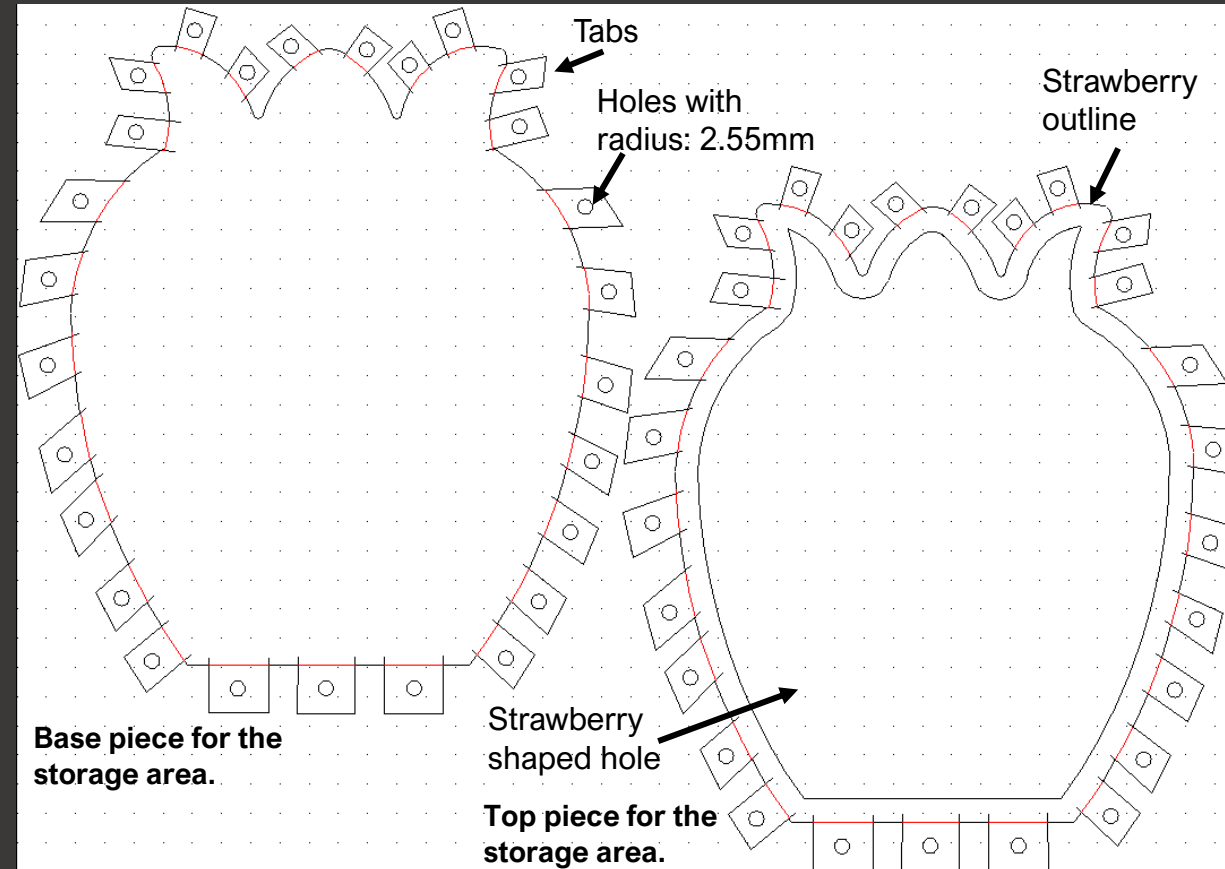
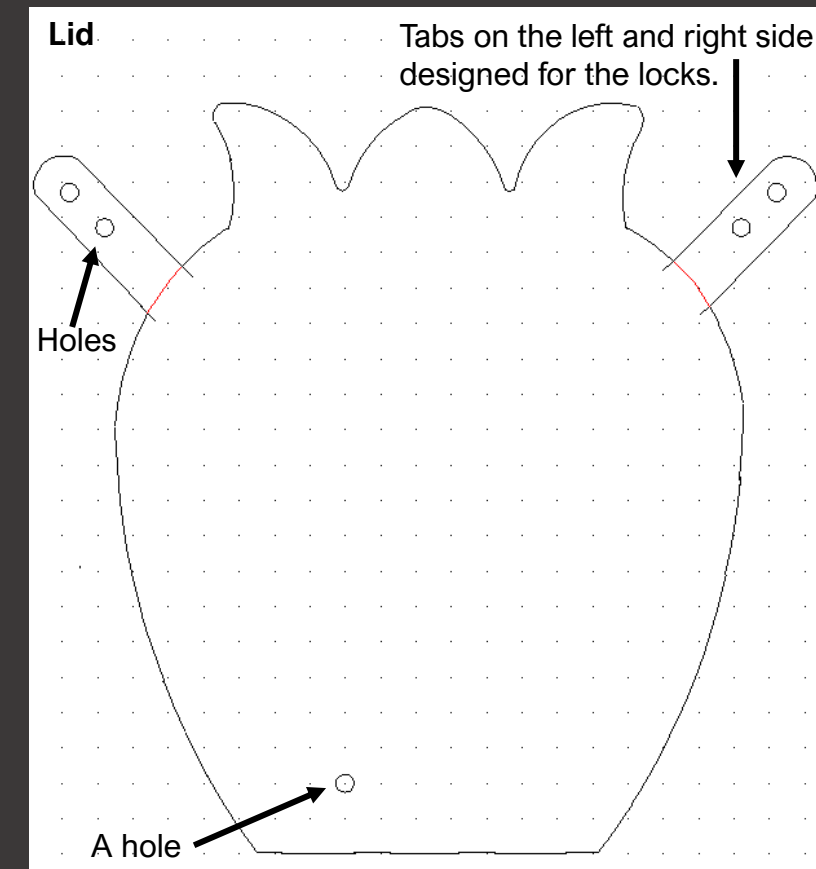

Record: Constructing the Final Portable Storage Organiser Model, Strawberry Inspiration

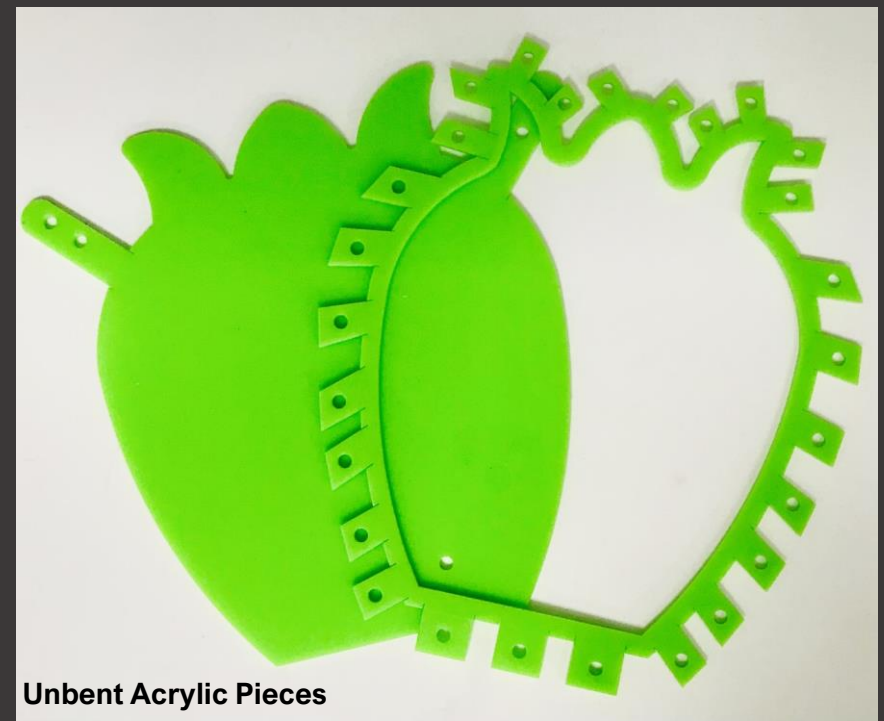

Unbent Acrylic Pieces

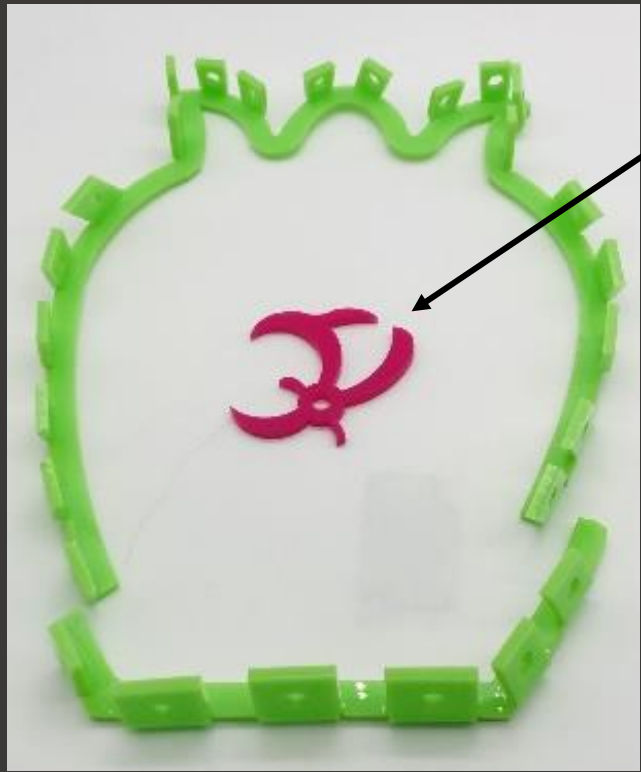
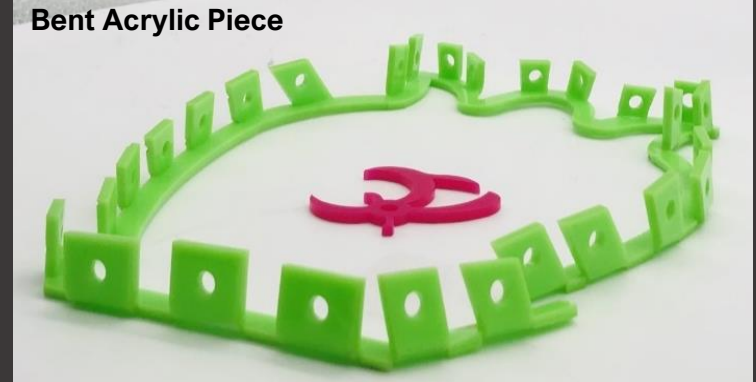
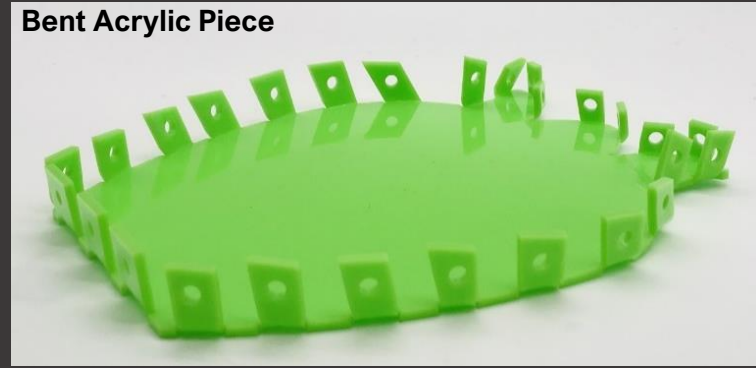

Logo with a hole in the centre for a dowel joint.

I have bent the tabs of the acrylic pieces, and then later I'm going to construct them together onto the polypropylene sheet.

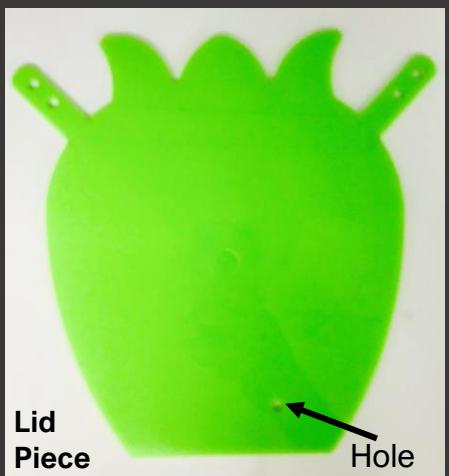

Lid Piece



The lid piece and the logo piece have been constructed together, and then I bent the tabs of the acrylic lid.

Record: Constructing the Final Portable Storage Organiser Model, Strawberry Inspiration

After I have finished bending all the acrylic pieces, I have started to join the pieces together to form the organiser's shape. During the time, there were not enough button studs, so I used paper fasteners to join the acrylic pieces and the polypropylene sheets together. In order to join them together, I have punched holes on the long polypropylene strip, and then I have positioned the holes with the acrylic tabs' holes, and then placed the paper fasteners in the two overlapping holes (acrylic and polypropylene) to secure them together. This have created the main shape of the portable storage organiser, where the thickness are shown. Later on, I have used the slotting technique and the pieces of curved polypropylene to create the interior layout, where there are a few number of holes on the pieces to be attached to the main organiser's shape using paper fasteners, so that the interior layout will also be placed in a secure position. Making this model have let me learn that paper fastener is a great and strong supply to be used in modelling.

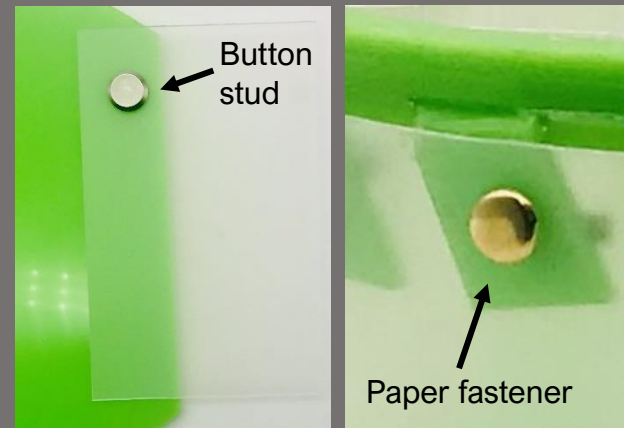

My Analysis:

Previously, I have planned to use the button studs to construct the acrylic tabs and the polypropylene sheets together. However, during the time, there were not enough button studs to construct the model, therefore, I started using paper fasteners. Both the button studs and the paper fasteners work well for the construction of the model, and they both have a huge strength to keep the model's pieces in place.

Interior Layout



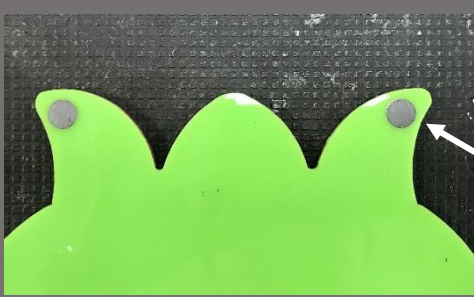

Circular magnets attached on the top surface of the lid, which is inspired by the strawberry's shape.

Making the features of the lid was a challenge, as when I was bending the acrylic tabs, I accidentally broke one of the tabs designed for the locks. Therefore, this has changed my plan, as I must figure out another way to make the locks, which can change the design. Doing some critical thinking makes me realised another way to design the locks, which is to attach magnets on both the lid and the storage structure. The only position that is good to place the magnets is near the top surface of the lid, as the space is bigger, which can reduce the chance of causing another damage. Therefore, I have to drill holes for the magnets' position to fit them securely. By doing this has changed a bit of the design, as drilling holes will allow the magnet to be seen from the inside and outside of the lid, so I have added three dark pink acrylic pieces onto the area, where the magnets are positioned to make the design look better. Near the bottom of the lid, I have attached acrylic hinge, so that it can be attached to the storage structure, which leads to a portable storage organiser that can open & close.

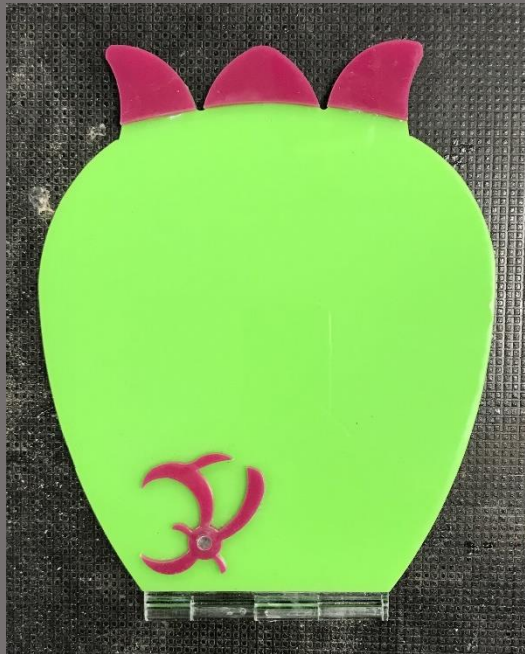

After finished the construction of the lid and the storage structure, I have started to add in the details for the design, which includes the handle and the cross-body strap. In order to attach the handle and storage structure together, I have also punched holes on both of them and used paper fasteners to join them together. Another feature is the cross-body strap, which I have made two structures with square shaped wire attached to a green cotton strap using button studs, and then they are attached on both sides of the organiser. After that, the cross body strap are attached to both of the structures using button studs.

Square shaped wire Button Studs



Final Model of the Portable Storage Organiser Design

The final model of the "portable storage organiser" has been made using various materials, including acrylic sheets, polypropylene sheets, paper fasteners, button studs, thick wires, acrylic stick, cotton strap, magnets and acrylic hinges.

Overall, this final model is a positive outcome, with the parts and features built neatly and the function works nicely. Even though I have faced some challenges, I have still tried to overcome them by using different techniques and tried not to change the design. For instance, in the design, I have created a "protection layer" to secure the art supplies in the storage area and prevent the supplies from getting disorganised. However, in this final model, I found it challenging to attach the acrylic protection layer to the model, as the polypropylene sheet is thin and it did not have the strength to hold many pieces of acrylic, which can cause damage. Therefore, I did not include the protection layer, but in the actual design the protection layer will be included.

Another feature that I did not include is the stationery pockets designed in the interior of the lid. The reason is that I did not build a thickness for the lid, therefore it was a challenge to attach the pockets on the lid. If I attach the pockets to the final model, then it would be difficult to close the organiser. However, in the actual design the stationery pockets will also be included. Throughout the development of this model, I have learnt many skills, and different kinds of ways to overcome the challenging problems.

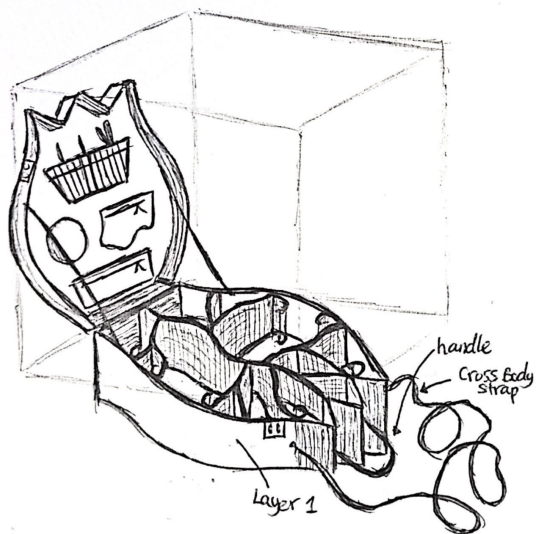

A person holding the portable storage organiser design!



I have used the collage technique to demonstrate a person using the scaled-up portable storage organiser design, and to roughly show the scale of the organiser.



Interior Layout: Final Model of the Portable Storage Organiser Design



Magnets

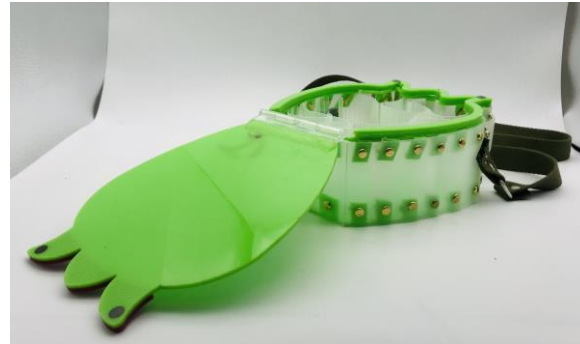

Final Portable Storage Organiser Design & Desk Design

I have used the collage technique to demonstrate the function of the two products by placing the model of the portable storage organiser into the design of the cupboard on the left leg of the desk model. This shows that the desk design has large storage spaces to store things, including the portable storage organiser. By doing this roughly shows the scale of the two products and shows that the portable storage organiser and the desk are a set of product, as both designs have some links (e.g., the size and the logo). However, the portable storage organiser can just be used as a single product and be carried around by the user .



SketchUp Drawing of the Final Portable Storage Organiser Design

Record

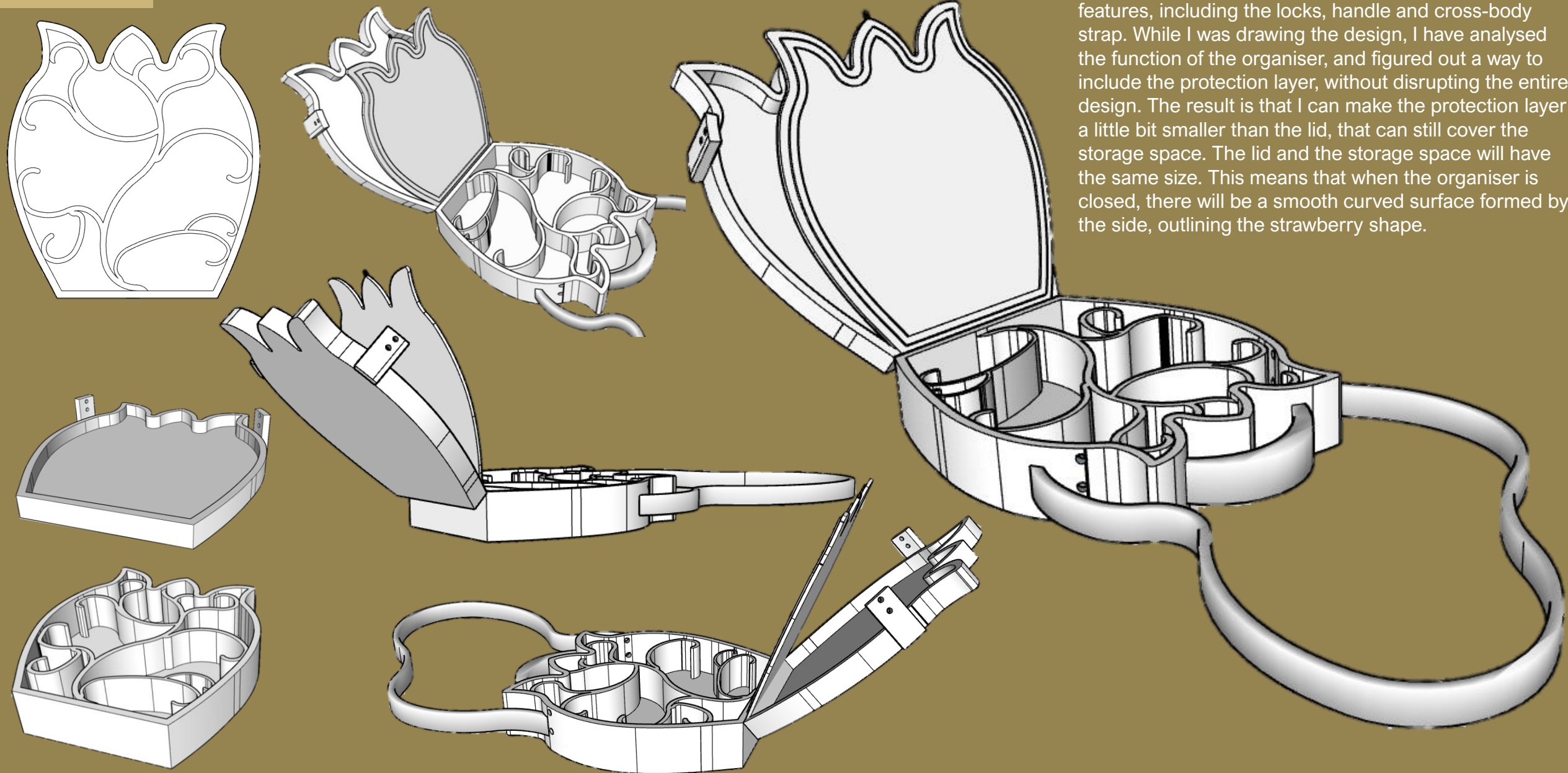

In the SketchUp drawing, I have included some small features, including the locks, handle and cross-body strap. While I was drawing the design, I have analysed the function of the organiser, and figured out a way to include the protection layer, without disrupting the entire design. The result is that I can make the protection layer a little bit smaller than the lid, that can still cover the storage space. The lid and the storage space will have the same size. This means that when the organiser is closed, there will be a smooth curved surface formed by the side, outlining the strawberry shape.



The height of the space divider is a few cm lower than the storage space, so that a gap will form, which have the same thickness as the protection layer. This means that the protection layer will secure the storage space tightly when it is closed.

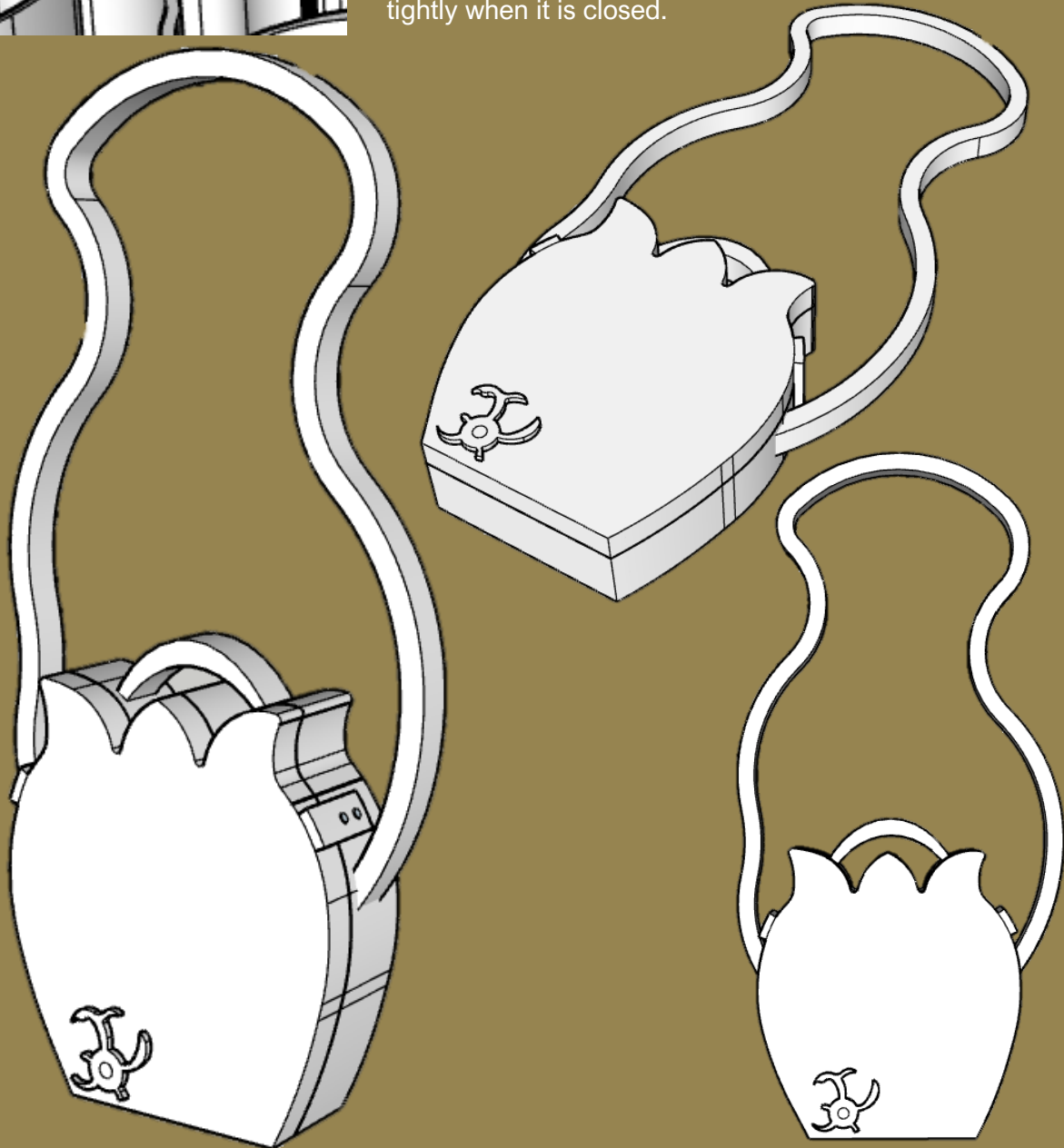

People holding the portable storage organiser design!



I have used the collage technique to demonstrate humans using my portable storage organiser design, and to roughly show the size of the organiser.

SketchUp Drawing of the Final Desk Design

Record

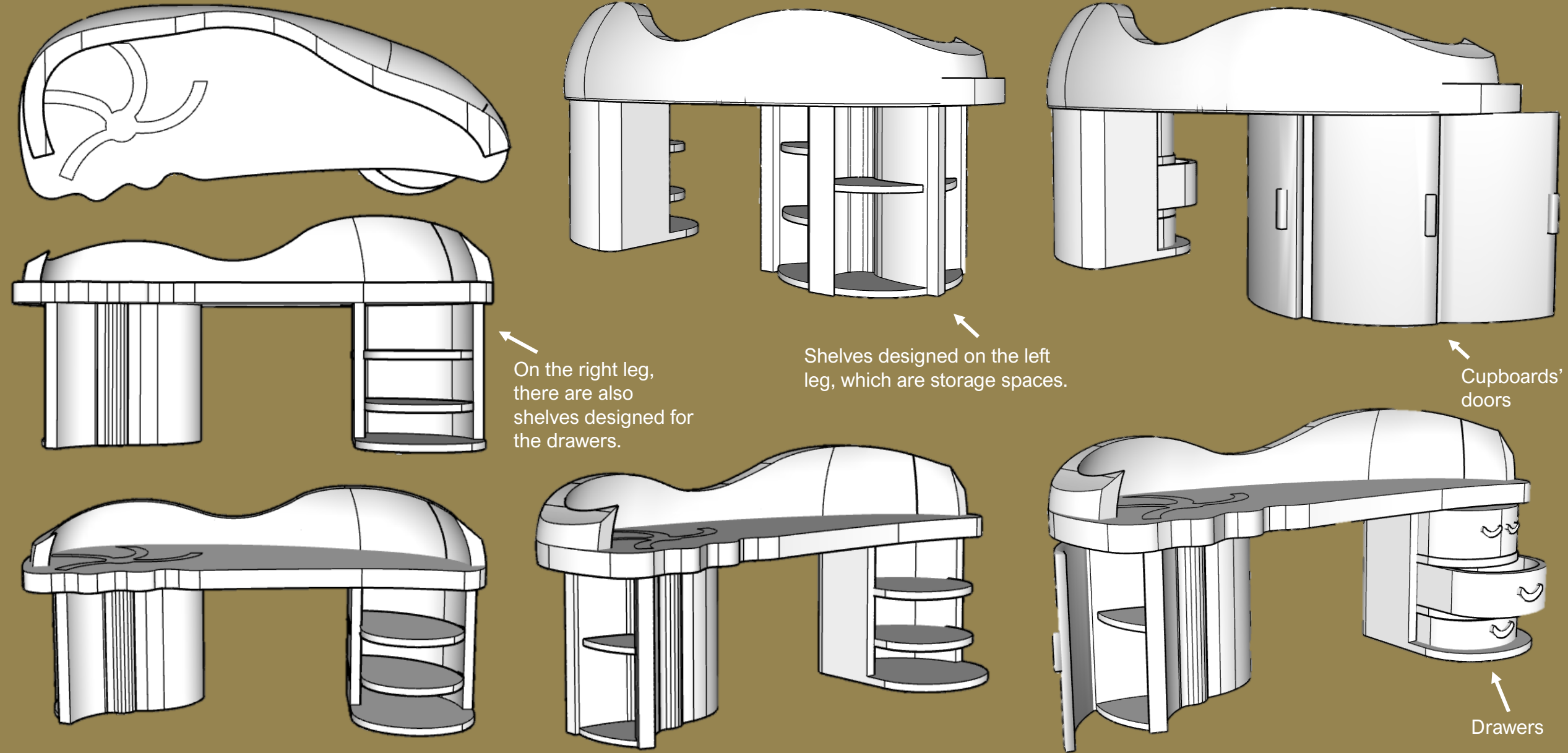

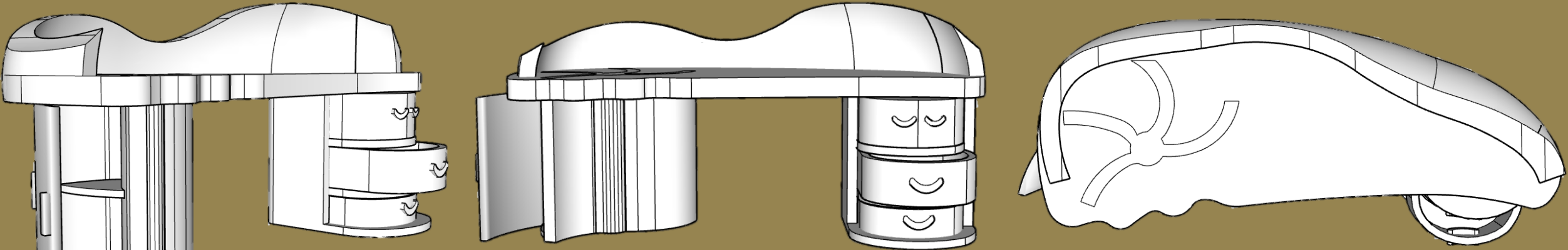

Getting ready to work!

I have used the collage technique to demonstrate a person using the desk design, and to roughly show the size of the desk.

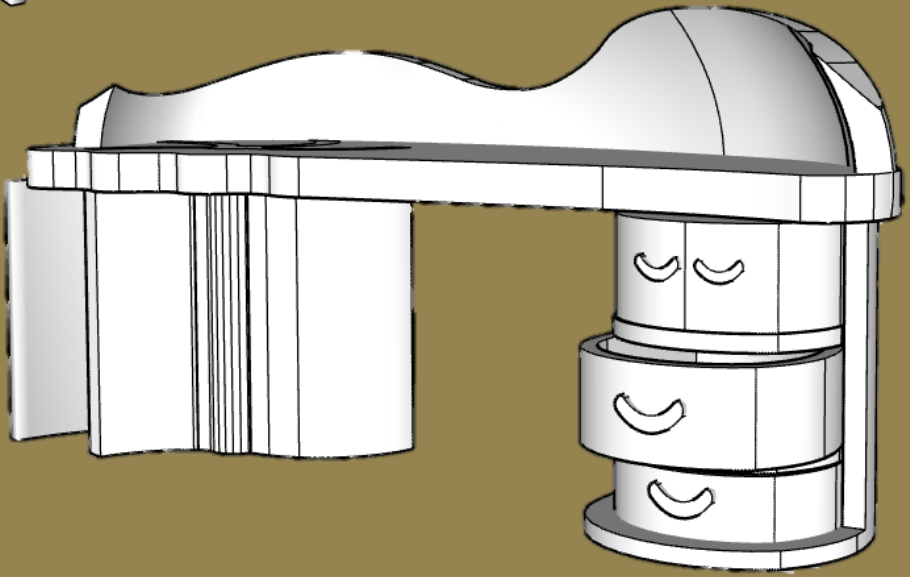

In this SketchUp drawing, I have included the design of the drawers and the cupboards' doors. Drawing this SketchUp model have made me start to think deeply on the function of the design, and given me understanding on the ways to construct the desk features. For instance, I started to think about the ways to make the drawers open smoothly, which includes attaching the drawer slides, and for the cupboards' doors, I need to attach hinges.



SketchUp Drawing of the Final Portable Storage Organiser Design & Desk Design

The portable storage organiser and the desk design are a set of products. Here, I have roughly shown the scale of the two products by placing them together. The cupboards of the desk design have been designed to store any products, including the portable storage organiser.

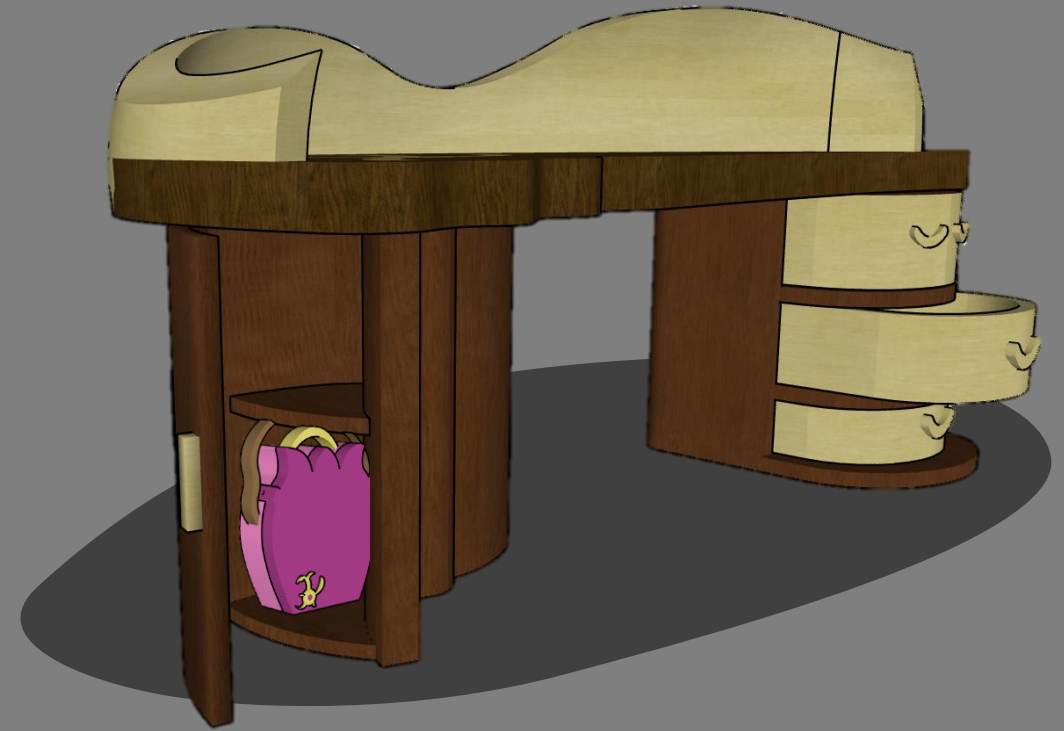

Front View





Plan View



Back View

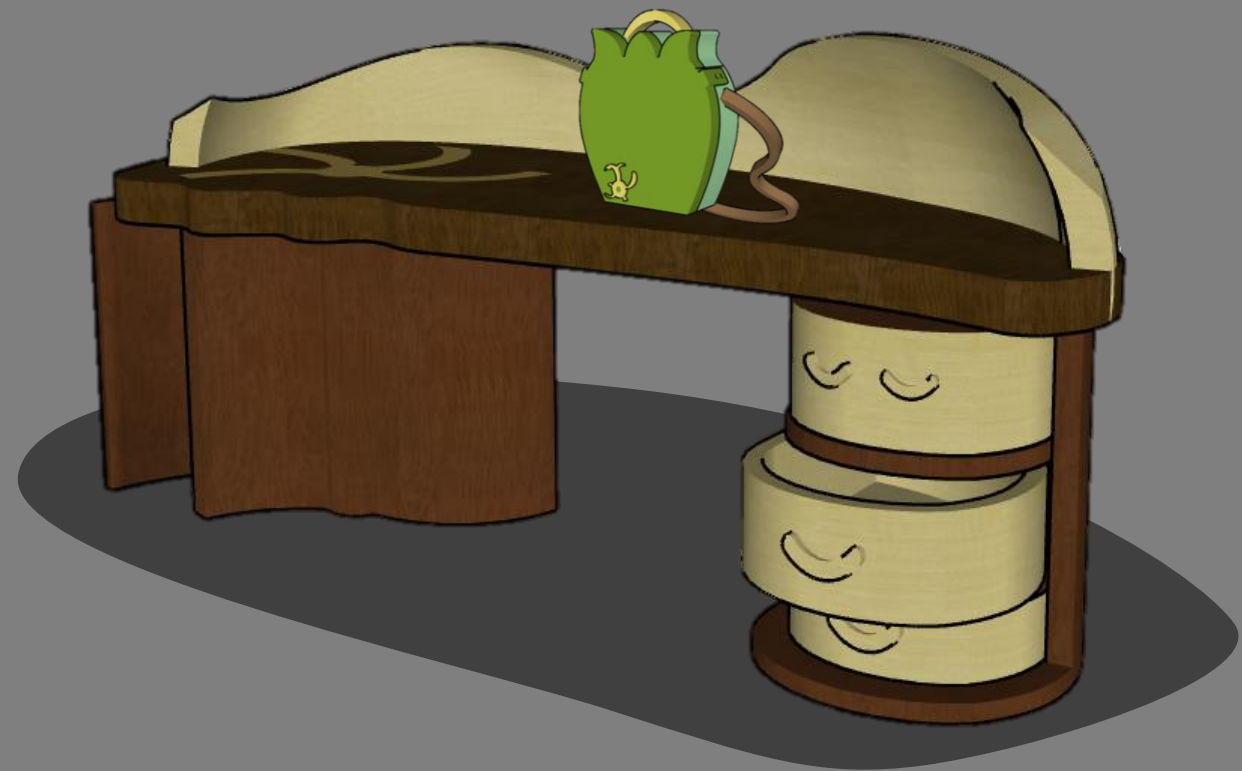
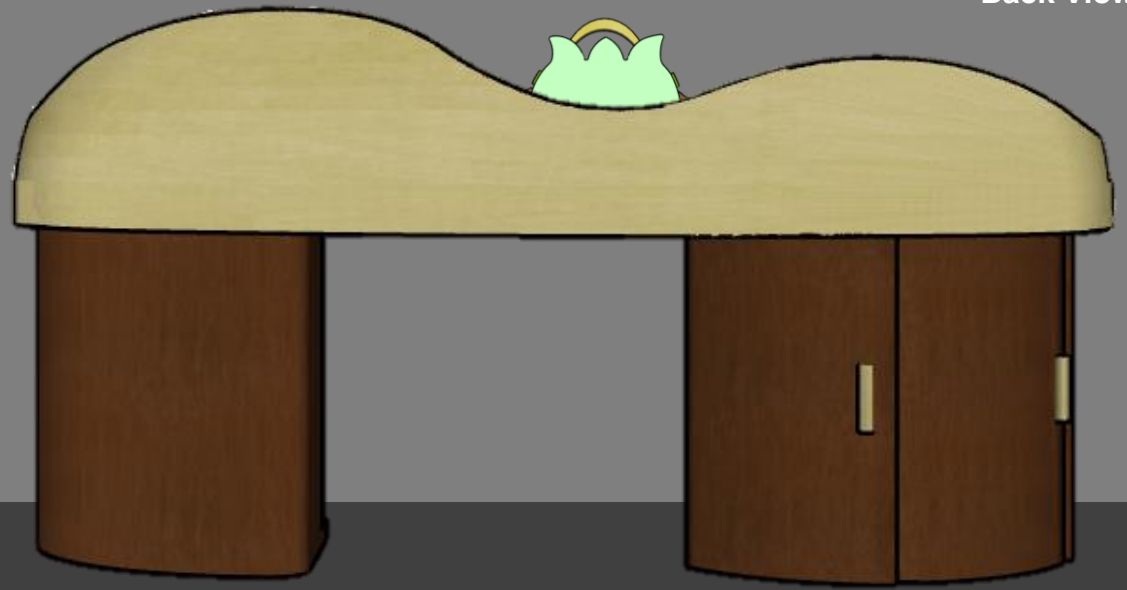



Evaluation

During the process of designing a portable storage organiser and a desk, I have learnt new experiences and skills and faced new challenges. This is evident as I have gone through lots of critical thinking and doing developments on the measurements of the designs to make products that are up to scale. For this project, I chose to design a portable storage organiser for Art & Design students, as I realised that sometimes young artists do not like staying in the same atmosphere doing things, and they enjoy travelling to different places or working in different environments to get inspiration. Therefore, I decided to design a portable storage organiser for young artists to store their art supplies and equipment, inspire them to be creative on the move and brighten their lives. Another product I chose to design is a desk for professionals, as I realised that sometimes professionals' desks get disorganised easily when working and do not have time to organise the files and other things. Therefore, I decided to design a multifunctional desk with various storage spaces for professionals to store their files and items when they do not have time to organise them. While designing the final portable storage organiser, I found it challenging to figure out a way to construct the naturally shaped model using the available materials and professional skills. For example, in the beginning, I built a cardboard version of the portable storage organiser using lots of supplies, including a hot glue gun, tapes and double-sided tape. After researching the construction techniques, I finally figured out a way to make the final portable storage organiser by using highly skilled materials (acrylic sheets) and more skills, including tab joints and using acrylic bending machine, which were great new experiences. While developing a desk design, I also faced some challenges, including figuring out a construction technique that could work on the design. I was glad I had done more research on the construction technique, including wood joints, which helped me understand how to construct the final desk design. Going through all these experiences and developments have built my design knowledge and successfully achieved the brief and specification, which would allow young artists to be creative on the move and professionals to keep working hard in a tidy environment, that brighten both of their lives.

The outcome of both the portable storage organiser and the desk look fantastic. However, I made a few mistakes while building the final portable storage organiser. When I was building the final portable storage organiser model, I realised that building a thickness for the acrylic lid would be better, so that the stationery pockets could be constructed on it. But I found that some of the material (polypropylene) may break easily, which taught me that I should have built the model using a much stronger material that has the strength to hold other pieces and parts. Another mistake I made was also related to the mistake of using polypropylene, which led me not to be able to construct the protection layer, as the polypropylene sheets are too thin, and they need to have the strength to hold pieces of acrylic parts. Using some polypropylene to construct the final portable storage organiser model changed some of the final design. However, stationery pockets and protection layer would both be included in the actual design. Despite this, I am happy with my final designs and models, which have led me to create a portable storage organiser and a multifunctional desk that show my idea of brightening people's lives and making their lives easier.



To what extent can designers create products that can bring the community together, and brighten people's lives?

Introduction:

In the world, there are various products designed for different purposes. Therefore, I will be discussing the ways in which designers create products that can bring the community together and brighten people's lives. The products that I will be talking about are lighting and furniture designs, which are necessary products people need in their everyday lives to work and survive. For instance, products are designed for many reasons, which include manufacturing products for people to earn income, make people's lives more interesting, produced for basic usage, and more. This shows that humans are surrounded by products in their everyday life. Therefore, I will be exploring how the designing process works, for those designers to create successful products that can influence people's lives. The theme I have chosen to talk about is "Natural & Organic", as humans are a part of nature. Also, sometimes products are created for no reason and cannot have links with human emotions. Therefore, I will do research on how those designers create products in natural ways that can spread feelings, form bonds with humans and lighten people's lives.

In my essay, I will be analysing two designers that have experiences in designing products based on the theme, natural & organic. Marcel Wanders is a Dutch interior and product designer who created "Nightbloom lighting" in 2019. Thomas Heatherwick is a British designer who designed the "Spun chair" in 2010.

Marcel Wanders:

Marcel Wanders is a Dutch interior and product designer, born in Boxtel, Netherlands, in 1963. He has worked with various companies, such as Louis Vuitton, Swarovski, and Puma. His aim in design is that "As a designer, you have the gift of really being able to add fun and value to people's lives."¹. This suggests Marcel has been designing products that can spread emotions, and let people have the chance to explore their lives joyfully by using the products that are created in interesting ways. After Marcel had basic experiences as a designer, he realised that designing objects that blend into the environment are crucial, as they can make the world a better place to live in and spread emotions. For instance, Marcel stated that "incorporating the local culture and natural beauty of a region allows the furniture to then create a sense of place"², which shows that when designing an object, it's important to think about the location, and how it's going to be fit into the place, as this can have influences on the way people view the design.



Nightbloom lightings

One product designed by Marcel Wanders is the "Nightbloom lighting"³, a lighting design inspired by flower petals, with many different types of lighting. For instance, pendant lamps, floor lamps, wall lamps, and table lamps are all designed in flower petals' shapes. This shows that Marcel tried to design the lighting in different ways, so that the users have more choice on where to use the lighting, rather than only having one fixed option. For example, people can choose to use the Nightbloom lighting on the desk as a table lamp, or in other ways. The Nightbloom lighting is made of porcelain, a ceramic material made by heating clay-type materials to high temperatures. By using porcelain allows the crafters to use their hands to create beautiful & natural petals' shapes and textures, with each petal having tiny bits of differences. Having products made by hand can spread emotions to people and make people feel connected, as the users can feel the amount of effort the crafters put in to make the product, which can make the users feel involved and included.



Designing the Nightbloom lighting in a natural way can make people feel calm, and the shaping can spread a sense of nature, making people feel like they are in a garden or a park. Placing this design inside a space can lighten up the entire space, and turn the area into a place that can bring people together. This is reflected when Marcel stated that his mission is to "create an environment of love, live with passion, and make our most exciting dreams come true"⁴. Therefore, this suggests that he has considered his designing process precisely to design products that can add interaction to people's lives, and bring people together to make their lives full of explorations. Furthermore, Marcel believes that design is an expression of times and cultures; therefore, there will be different types of designs during different periods.

Thomas Heatherwick

Thomas Heatherwick is a British architect and product designer, born in London, in 1970. He is also the founder of the Heatherwick Studio in London, working with a team of around 200 members. In Thomas' design projects, he has linked a lot to nature, with some products designed in wavy style, bumpy style, organic style, and various textures. This expresses how Thomas loves exploring and experimenting with new ways of designing, which led him to design a range of cool products, such as the extrusions furniture, the Spun Chair, and the new bus for London. In his designs reflect the statement in which he said, "I don't feel I'm trying to make art. I'm trying to make interesting things. People can relate to that."⁵. By saying this, Thomas has been designing products in ways that people can understand and in ways that cheer up people's moods to make them feel the joy of using those products.



Extrusions Furniture



Spun Chair

One product designed by Thomas Heatherwick is the "Spun Chair"⁶, which is a chair that can spin around the moment a person sits on it. The spun chair looks like a sculptural vessel, but when a person leans on the side of the chair, it starts to become a fun and functional chair that allows the user to move around from side to side or spin around randomly in an entertaining way. Thomas has designed all the spun chairs in the same format, and used the same materials, which are metals and polypropylenes, but some of them have different colours and textures designed to fit into different environments. For instance, some of the chairs are made using different colours of metals, including brown, red, silver, granite, and natural green, which can blend into different environments. An example is shown in Singapore, where a range of granite spun chairs are placed on the skyscraper, where people can sit and spin around to have fun and relax. Placing the spun chairs on the skyscraper allows public interactions to occur, as people want to sit and take some time to relax, which also brings the community together and brighten people's mood.



Granite Spun Chairs placed on Singapore's Skyscraper

Around the world, a range of spun chairs are placed in public areas, including high streets, parks, and indoor & outdoor spaces, which gives people a chance to experience sitting on them and brings public interactions. This links to Thomas' statement, which he stated that "I'm interested in creating things that are all around us, that engage us."⁷. This suggests that Thomas Heatherwick likes to design products that are simple and engaging, as they can bring the community together, and give him the chance to meet new people, which can help him in his design process. For instance, some spun chairs are placed in the resting area of the workplace, so that during a lunch break, employees can go to the resting area to sit on the spun chairs to relax, which connects people, and forms public interactions that may help with their business work. In addition, Thomas Heatherwick designed a simple spun chair that looks fun and can lighten the atmosphere of the space, which can also bring the community together. This is reflected when Thomas stated, "You can make people feel valued or cared for by design alone. It's not purely about money. It's about how we choose to value human experience."⁸. By saying this suggests that Thomas has a warm heart, and tries to use his design skills and life experiences to create products that can make people's lives more colourful. Thomas' spun chair designs have brought a positive cycle to people's lives, as wherever the chairs are placed, they can always bring the communities together, giving people a chance to make new friends and feel included, which brightens their lives.



Spun Chairs placed in public areas which bring the community together.

Conclusion

In general, Marcel Wanders and Thomas Heatherwick have a common concept, which is to consider their users. Both designers have put effort into every little detail of the designing stages to create products that can bring the community together and brighten people's lives. In Marcel Wanders' design stages, he first researches the environment where the product will be designed and the users who will use the products. Then, after understanding the people and the environment, he starts to recognise the ideas he can create to bring people together and change their lives. This clearly shows me that every designer has the chance to develop products that can change people's lives. However, it depends on whether those designers have put in enough strength and warmth to design products that can spread emotions and make people feel cared for, bringing the community together.

Both designers' works demonstrated a series of styles in each product design, giving people more choices on how they want to use the products. For instance, in Marcel Wanders' Nightbloom lighting design, he has designed a series of styles for people to choose from, which includes ceiling pendant chandeliers, floor lamps, desk lamps and wall lamps, all have natural flower petals' inspiration included in them. This gives people more choices to choose the kind of Nightbloom lighting that best suits their situation, rather than having only one style, as everyone has a different purpose for using the lighting. For example, some people want to use Nightbloom lighting designed as a wall lamp that blends into their living room, others want to use the lighting as a desk lamp that can lighten up the desk surface, and for other purposes. Likewise, in Thomas Heatherwick's spun chair design, he has created a range of colours and textures for one design, including a list of rainbow colours, natural colours which blend into a natural environment, and metallic colours. This means that people have more choice, and they also get the chance to choose the spun chair that best blends in with the atmosphere they live or work in. Placing products that blend well with the environment can influence people's lives. Therefore, designing the same products in different styles or colours can lighten people's moods, and spread emotions through public interaction.

Overall, Marcel Wanders' and Thomas Heatherwick's designs have demonstrated the link between nature and public. Nature is vital to designing a healthier future and can spread a sense of colourfulness and positiveness to humans, which can lead to positive attitudes. Consideration of the public in design is crucial, as design can influence people's lives and interactions with others. Therefore, the designers must consider the designing stages carefully to achieve a positive result. In addition, the research has taught me that to create products that can bring the community together and brighten people's lives, I need to put strength and warmth in the designing process and understand the people's feelings by communicating with them and doing research. Interestingly, I have a designer mindset,

knowing that as a designer, I can lighten people's lives, making them more fun and enjoyable. Therefore, I can design products that can positively influence people's lives if I put my strength and warmth into the design process.

Bibliography:

Marcel Wanders

<https://www.marcelwanders.com/work/nightbloom>

<https://formfluent.com/blog/2020/3/10/nightbloom>

<https://www.cladglobal.com/architecture-design-features?codeid=32296>

<https://www.marcelwanders.com/projects>

[https://www.re-thinkingthefuture.com/know-your-architects/a7458-marcel-wanders-ideology-and-](https://www.re-thinkingthefuture.com/know-your-architects/a7458-marcel-wanders-ideology-and-philosophy/#:~:text=Marcel%20believes%20that%20people%20need,design%20world%20of%20the%20future.)

[philosophy/#:~:text=Marcel%20believes%20that%20people%20need,design%20world%20of%20the%20future.](https://www.re-thinkingthefuture.com/know-your-architects/a7458-marcel-wanders-ideology-and-philosophy/#:~:text=Marcel%20believes%20that%20people%20need,design%20world%20of%20the%20future.)

<https://architecturenow.co.nz/articles/a-people-person-marcel-wanders/>

Thomas Heatherwick

<https://www.dezeen.com/2010/05/04/spun-chair-by-thomas-heatherwick/>

<https://www.brainyquote.com/lists/authors/top-10-thomas-heatherwick-quotes>