

Write your name here

Surname

Other names

Edexcel

International GCSE

Centre Number

--	--	--	--	--

Candidate Number

--	--	--	--	--

Human Biology

Unit: 4HB0

Paper: 02

Tuesday 10 January 2012 – Afternoon

Time: 1 hour

Paper Reference

4HB0/02

Candidates may use a calculator.

Total Marks

Instructions

- Use **black** ink or ball-point pen.
- **Fill in the boxes** at the top of this page with your name, centre number and candidate number.
- Answer **all** questions.
- Answer the questions in the spaces provided – *there may be more space than you need.*
- Show all the steps in any calculations and state the units.

Information

- The total mark for this paper is 60.
- The marks for **each** question are shown in brackets – *use this as a guide as to how much time to spend on each question.*

Advice

- Read each question carefully before you start to answer it.
- Keep an eye on the time.
- Write your answers neatly and in good English.
- Try to answer every question.
- Check your answers if you have time at the end.

Turn over ►

P40129A

©2012 Pearson Education Ltd.

1/1/1/



PEARSON

Answer ALL questions.

1 Erica tested the energy content in a food sample. She set up the following apparatus.

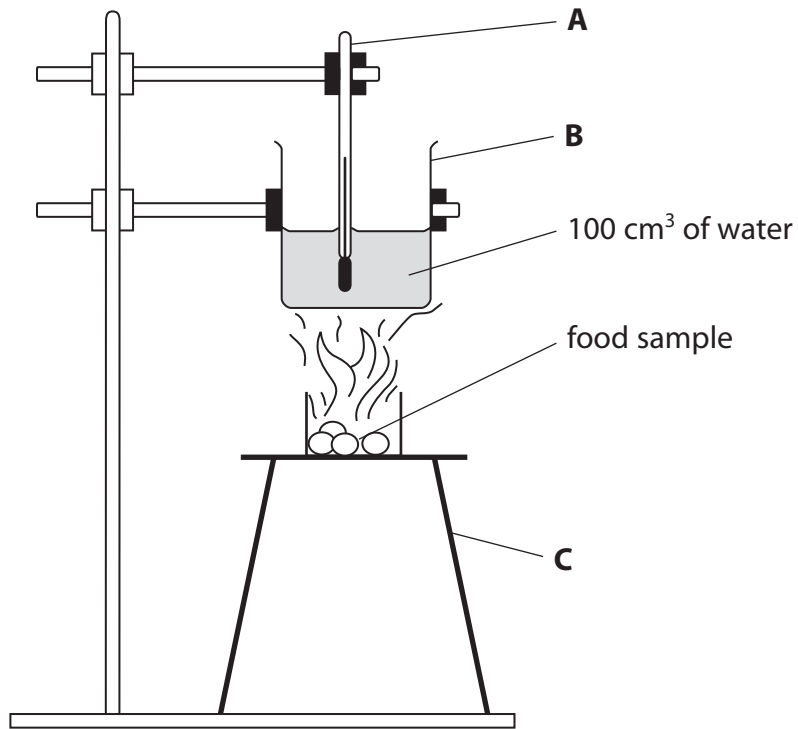

(a) Name the apparatus labelled **A**, **B** and **C**.

(3)

A

B

C

(b) State **two** safety precautions that Erica should take when using the apparatus.

(2)

1

.....

2

.....



(c) She measured the temperature of the water before and after heating it with the burning food sample.

Diagram X shows the temperature of the water before it was heated.

Diagram Y shows the temperature of the water after it was heated.

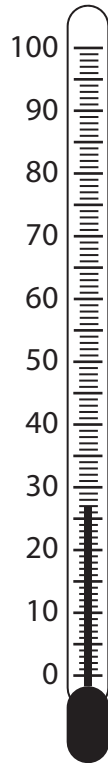

Diagram X

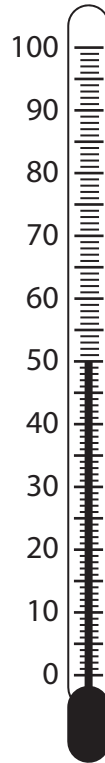

Diagram Y

(i) State the temperature of the water before it was heated.

(1)

..... °C

(ii) By how much did the temperature of the water rise when it was heated with the burning food sample?

Show your working.

(2)

..... °C

(Total for Question 1 = 8 marks)



- 2 (a) The table shows the energy requirements per day in kilojoules of different groups of people.

Sex and age (years)	Energy required per day (kJ)
boy or girl 0–1	3 300
boy 9–12	10 500
girl 9–12	9 600
boy 13–18	12 600
girl 13–18	9 600
man 18–35	12 600
woman 18–35	9 200
man 75 and over	8 800
woman 75 and over	8 000
pregnant woman	10 000
breastfeeding mother	11 300

- (i) Describe the relationship between energy requirements and age for males.

(2)

.....

.....

.....

.....

.....

.....



(ii) Explain the energy requirement for a woman who is pregnant.

(2)

.....

.....

.....

.....

.....

.....

(b) Some people do not have enough protein to eat.

Explain how this might affect their health.

(2)

.....

.....

.....

.....

.....

.....

(Total for Question 2 = 6 marks)



- 3 (a) Gas exchange takes place between the alveolus and blood capillaries in the lung. The diagram shows this process.

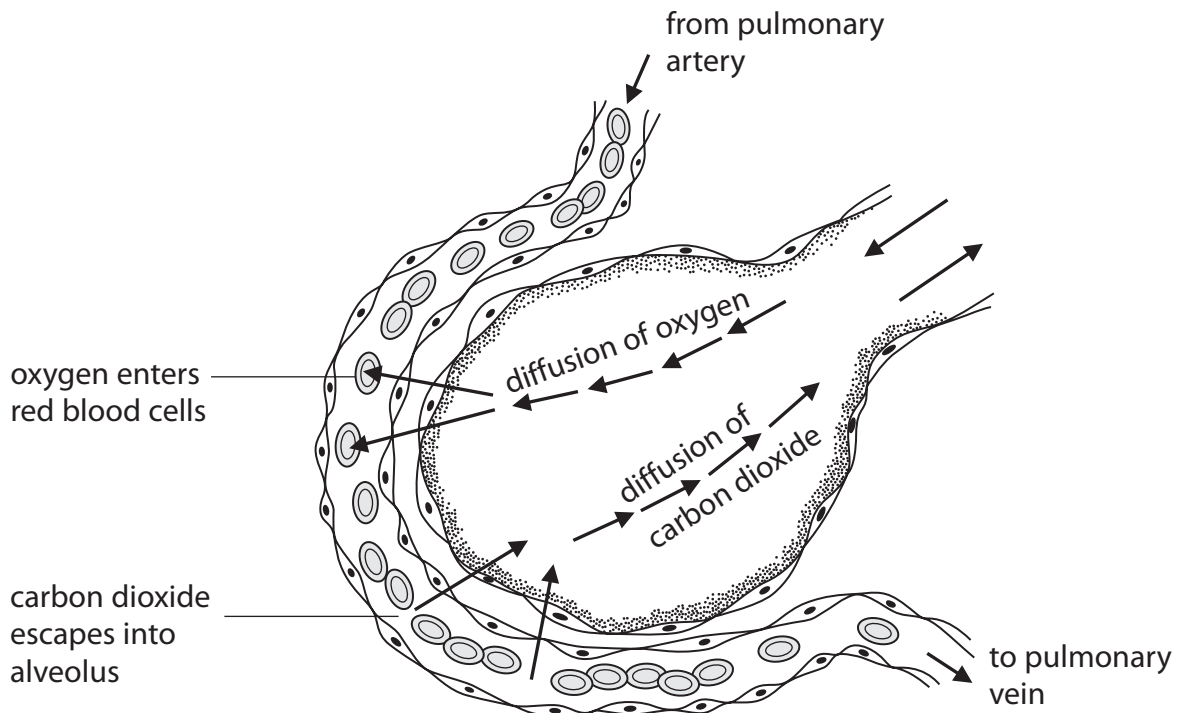

- (i) Put a cross in the box to indicate your answer. Oxygen moves from the lungs into the blood. This is because the concentration of oxygen in the lungs compared with the blood is:

(1)

- higher
 the same
 lower

- (ii) Explain how the blood around the alveolus maintains the diffusion gradient of oxygen.

(2)

.....

.....

.....

.....

.....

.....



(b) The apparatus in the diagram can be used to demonstrate the process of osmosis.

The U-tube has a selectively permeable membrane that prevents the passage of large molecules. A dilute glucose solution was poured into the left hand side and an equal volume of a concentrated glucose solution was poured into the right hand side.

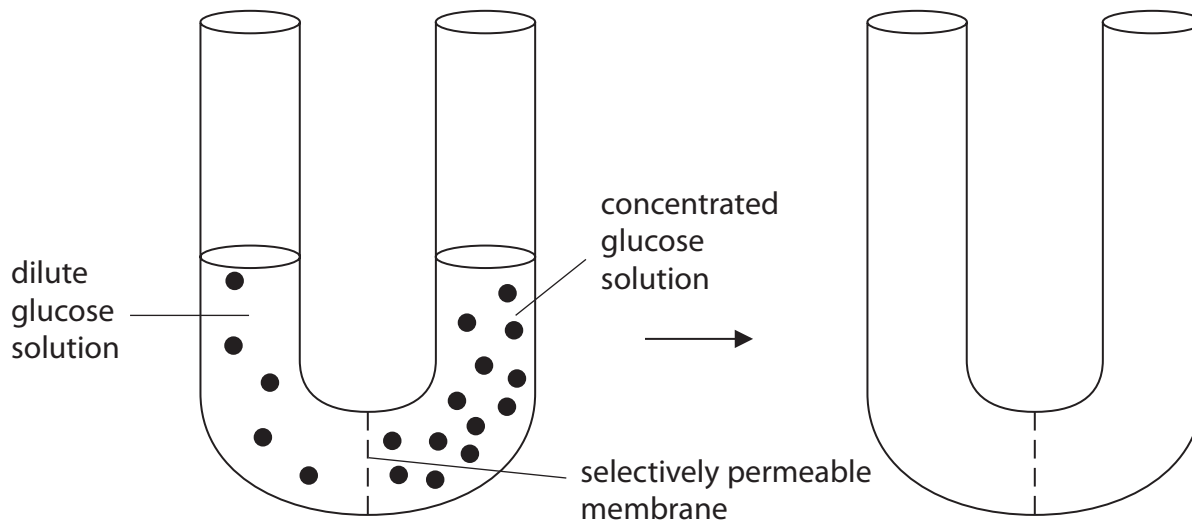

- (i) In the empty U-tube, draw where the levels of the solutions would be in each side after about one hour. (2)
- (ii) Which substance moves through the selectively permeable membrane? (1)

(Total for Question 3 = 6 marks)



4 (a) The diagram shows a motor neurone.

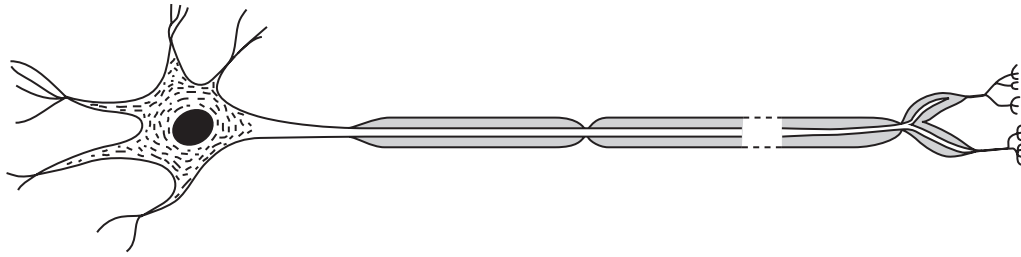

(i) On the diagram, label the following parts of the neurone: (2)

nucleus

myelin sheath

(ii) Draw an arrow underneath the diagram to show the direction of movement of the nerve impulse. (1)

(b) Complete the passage about control of blood glucose. (4)

If a person's blood glucose level becomes too high, the hormone called is released from the to bring it back down.

If a person's blood glucose level becomes too low, then the hormone called is released to raise it back to normal.

This is an example of feedback.



(c) Complete the table, which compares the nervous system with hormonal systems. (3)

Action	Nervous system	Hormonal systems
method of transmission	impulses in neurones	
speed of action		
length of effect		

(Total for Question 4 = 10 marks)



5 Philip investigated the effect of exercise on his breathing rate.

He took steady exercise over a period of time. He measured his breathing rate before exercising (0 minutes) and then at two-minute intervals during the exercise period.

(a) Philip carried out this experiment three times, in order to improve his investigation.

Circle the word in the box that best describes how this would improve the investigation.

(1)

accuracy	reliability	validity
-----------------	--------------------	-----------------

(b) The table gives the results of his investigation.

Time (min)	Breathing rate (breaths per min)			Average breathing rate (breaths per min)
	Experiment 1	Experiment 2	Experiment 3	
0	13	14	12	13
2	16	18	17	17
4	18	21	21	
6	21	23	25	23
8	24	18	27	23
10	26	25	27	26
12	27	27	27	27

(i) Calculate the missing average result. Show your working.

(2)

(ii) Circle the anomalous result in the table.

(1)



(iii) Describe the pattern shown by the results.

(2)

.....

.....

.....

.....

.....

.....

(iv) Explain why exercise changes the breathing rate.

(3)

.....

.....

.....

.....

.....

.....

.....

.....

.....

.....

.....

(c) Describe the effect of regular exercise on the heart.

(2)

.....

.....

.....

.....

.....

.....

.....

.....

.....

(Total for Question 5 = 11 marks)



6 (a) Complete the balanced chemical equation for aerobic respiration.

(3)

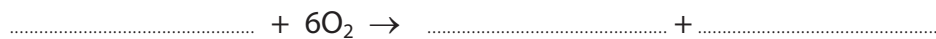

(b) The apparatus shown may be used in experiments on respiration.

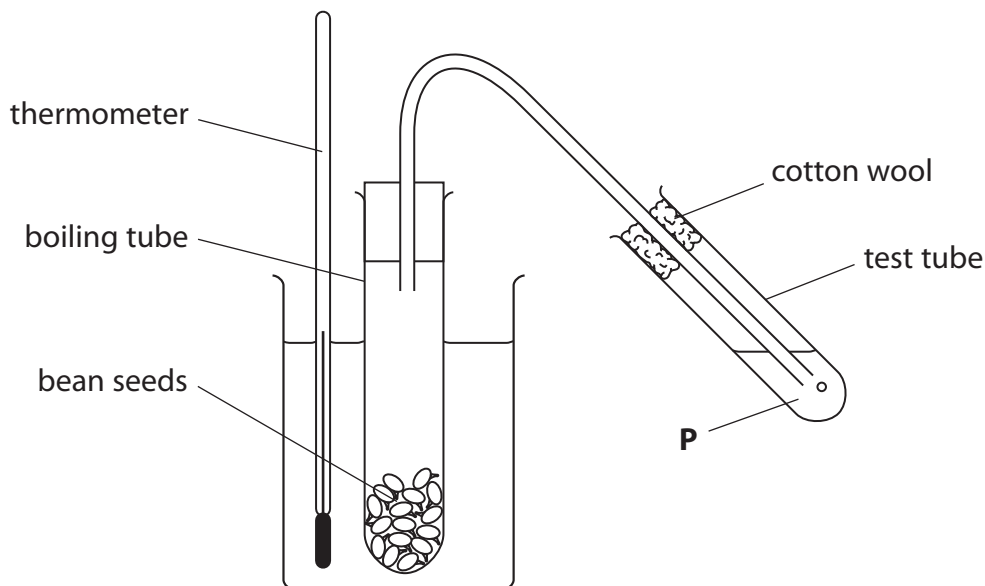

(i) Name the substance **P** which is used to show that carbon dioxide is given off and state the colour change you would see.

(2)

.....

.....

.....



- (ii) The rate of respiration can be measured by the rate at which bubbles appear in the test tube.

Describe a more accurate method of measuring the rate of respiration.

(2)

.....

.....

.....

.....

.....

.....

.....

.....

(Total for Question 6 = 7 marks)



7 (a) Untreated sewage can cause problems if it gets into rivers.

Explain the biological consequences of the pollution of rivers by untreated sewage.

(4)

.....

.....

.....

.....

.....

.....

.....

.....

.....

.....

.....

.....

.....

.....

.....

.....

.....

.....

.....

.....

.....

.....

.....

(b) The passage below is part of an article in a scientific journal.
Use the information in the passage and your own knowledge to answer the questions that follow.

Sewage Plants May Be Creating ‘Super’ Bacteria

Some bacteria at sewage treatment plants are becoming resistant to antibiotics and ending up in the environment. The job of a waste water treatment plant is straightforward. It removes harmful substances from sewage so that the water can be returned to the environment without harming people or wildlife.

But a new study suggests that the treatment process can lead to the spread of ‘super’ bacteria.

‘Super’ bacteria are resistant to antibiotics, so they ‘dodge the medical bullets’ that wipe out others. The more antibiotics that are used, the more resistant they become. Since bacteria reproduce quickly – one organism might turn into a billion overnight – and they share DNA with others, antibiotic-resistant genes spread very rapidly when conditions are right.



(i) Outline the role of bacteria in the treatment of sewage.

(3)

.....

.....

.....

.....

.....

.....

.....

.....

.....

.....

(ii) Scientists have carried out experiments which show that more bacteria are becoming resistant to antibiotics. They did this by growing bacteria on agar plates in the laboratory and counting the colonies produced.

Explain one way that they would have ensured that their experiment was a fair test.

(2)

.....

.....

.....

.....

.....



(iii) Suggest why the overuse of antibiotics may result in more bacteria becoming resistant to them.

(3)

.....

.....

.....

.....

.....

.....

.....

.....

.....

(Total for Question 7 = 12 marks)

TOTAL FOR PAPER = 60 MARKS

